



*BUILT TO DELIVER
DEPENDABLE POWER*



Installation and Operation Manual 2026

This guide is a simplified version of the Manufacturers guides – please see: [Sky Energy Downloads](#)

Safety Notice

 Works performed inside the SkyVolt MV must be done by a qualified electrician.

General Safety

FIRE

BSLBATT Batteries are a lithium-iron-phosphate based battery (LFP). It is the safest lithium chemistry. However, in the unlikely event of a fire, or if the unit emits smoke, sparks, flames, or vapour, produces a burning smell, becomes excessively hot or swells, leaks, or makes unusual noises,

Immediately:

- Evacuate the area.
- Call Emergency Services (000).
- Do NOT attempt to extinguish the fire.
- Do NOT touch, move, or handle the system or the batteries.
- Do NOT use water or household extinguishers unless trained and safe to do so.

Note: There must be a Safety Data Sheet for the BSL battery left with the Main Switchboard.

- The SkyVolt MV must only be installed by suitably qualified personnel who have read and are familiar with its operation and hazards.
- Do not attempt to charge the batteries with any other charging device or connect any device directly to the DC battery bus.
- Do not use a damaged battery.
- The shutdown procedure can be found inside the SkyBox next to the DC battery isolator.

Installation Safety

 The wiring diagrams and installation instructions are given as a guide only and compliance to appropriate standards is the responsibility of the installer.

Relevant standards are listed below:

- AS/NZS 3000:2018 Wiring rules.
- AS/NZS 5033:2021 Installation and safety requirements for photovoltaic (PV) arrays AS/NZS 4509.2:2012 Stand-alone power systems-Design.
- AS/NZS 1170.2:2021 Structural design actions-Wind actions.
- AS/NZS1768:2021 Lightning protection.
- AS/NZS 3008.1.2:2017 Electrical installations – Selection of cables.
- AS/NZS 5139:2019 Electrical Installations-Safety of battery systems for use with power conversion equipment.

 A battery can present a risk of electrical shock and high short-circuit current.

 Do not attempt to move the SkyVolt MV with batteries installed.

 Lifting hazard. Observe proper lifting techniques.

This document is subject to change at any time, please follow the install guide provided with your SkyVolt model.

Contents

Safety Notice	2
General Safety	2
Installation Safety	2
MV Cabinet + Combiner Box Dimensions	4
Battery Module Connection - Part 1	5
Battery Module Connection - Part 2	6
Wiring Overview	7
MV Battery Transport and Fixing	8
MV Battery Installation Location	9
MV Battery System Example Layout	10
BMS Cable Connection	11
MV Cabinet Start – Up	12
Inverter Commissioning	12
Start up system	12
Settings	12
Basic Settings	12
Battery Settings Page 1	12
Battery Settings Page 3	13
Grid Settings	13
System work mode page 1	13
System work mode page 2	13
Off-grid	13
Gen port use	13
Battery Settings Page 2	13
System Check	14
Wi-Fi Connection and Support	14

MV Cabinet + Combiner Box Dimensions

MV Cabinet - IP RATING: IP55 - PRODUCT WEIGHT: 2045kg

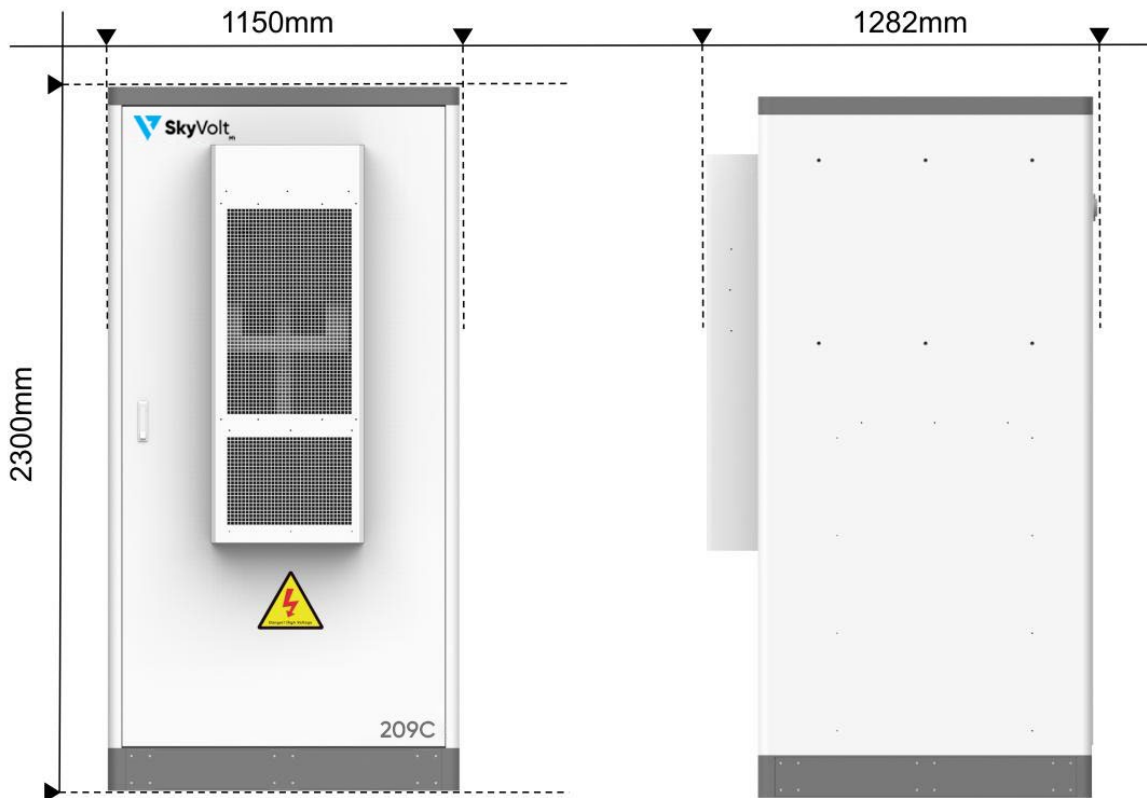

Combiner box - IP RATING: IP55 - MAX VOLTAGE: 1000VDC - MAX A: 300A

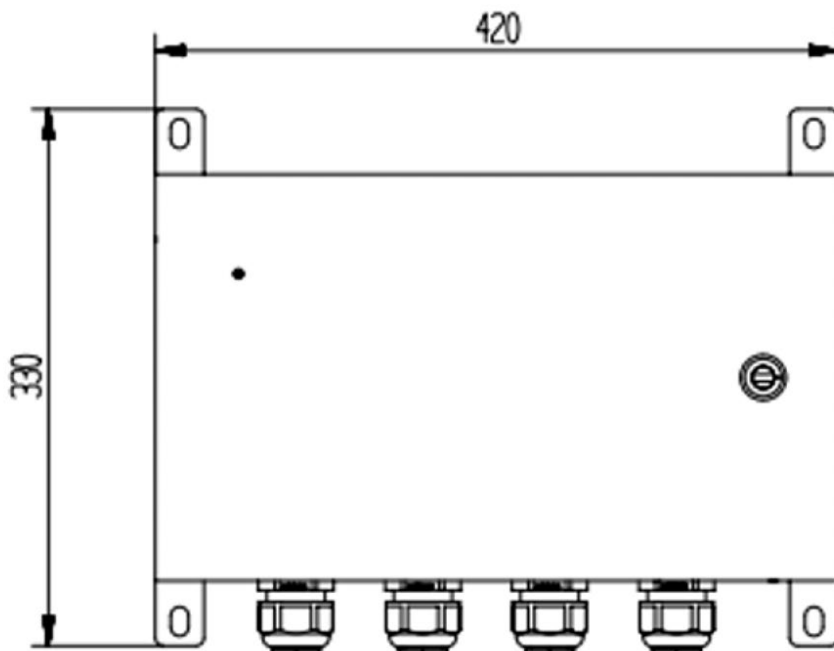

Battery Module Connection - Part 1

Using the battery link cables provided connect from the HV control box (bottom RH side).

- Up the right hand side
- Over to top left hand side
- Down to bottom left hand side
- Negative cable from last battery returns back to the HV control box
- Pull test these connections then give them another push to ensure proper connection

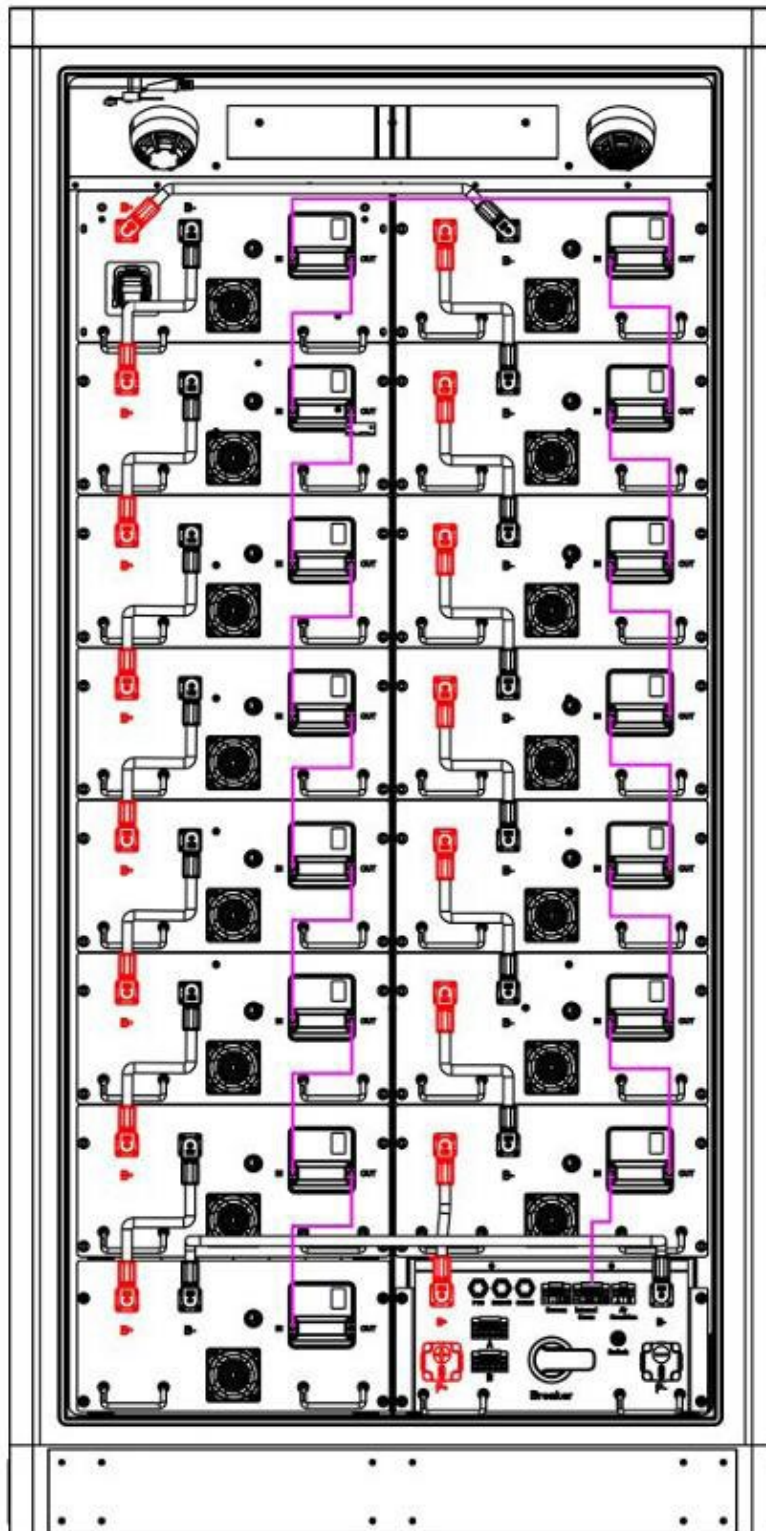

Battery Module Connection - Part 2

Cables run in and out of these holes in below image and can exit through the left and right hand side of the cabinet.

- 50mm M8 lugs connect to HV control module
- BMS cable connects to the PCS port
- Earth cable to earth busbar under HV module
- AC unit wire connects to circuit provided (use junction box or other method)

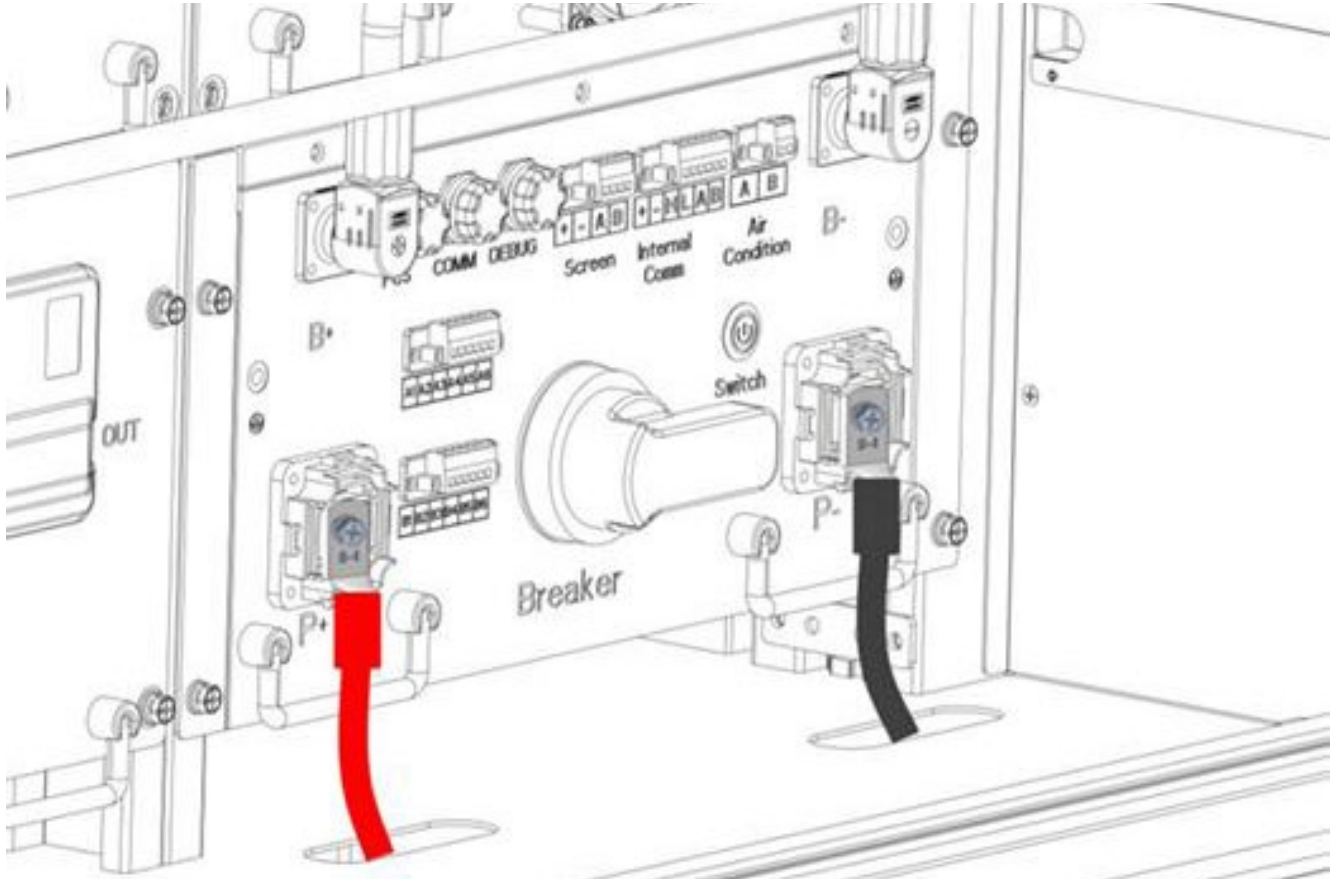

Wiring Overview

Wiring from the battery to the inverter:

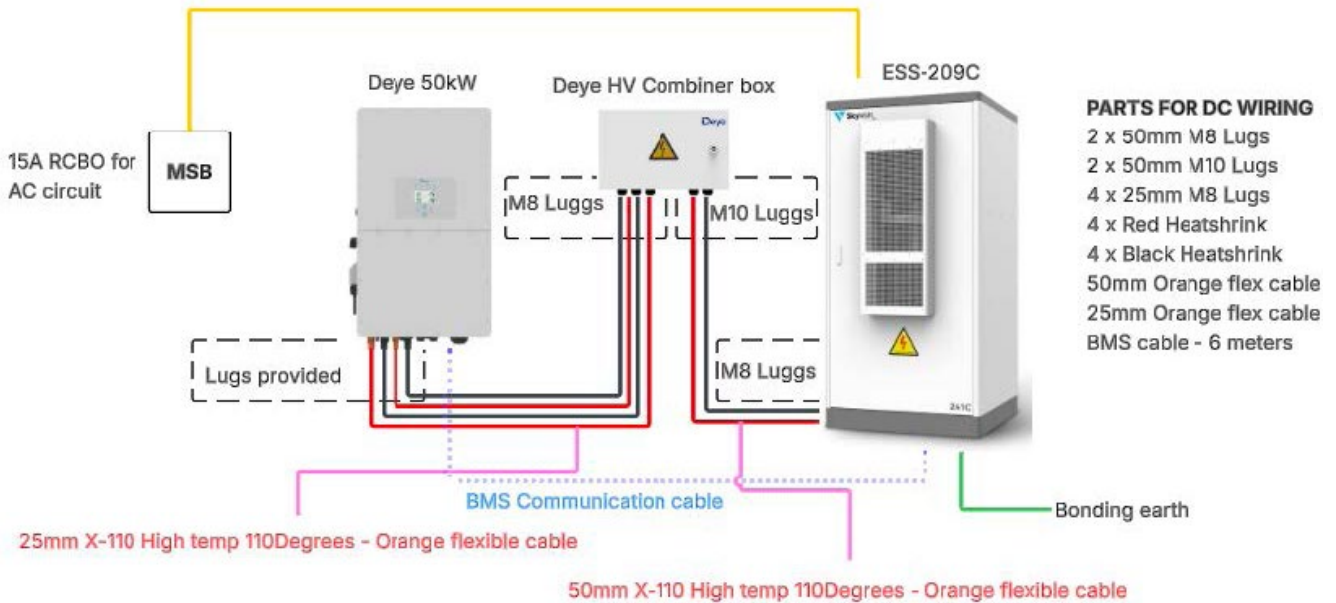

SKYVOLT MV BATTERY

- 50mm DC cables to combiner box
- BMS cable to inverter
- 25mm earth cable from MSB or Inverter to MV cabinet busbar
- 25mm earth cable from MV cabinet busbar to external bonding point of cabinet
- 15A circuit to power AC unit (connect with a junction box inside MV cabinet)

DEYE 50kW INVERTER

- 2 pairs of 25mm DC cable to combiner box
- BMS cable from MV cabinet
- 25mm earth cable to MV cabinet

The Deye inverter has 2 x 25mm battery inputs in parallel; we use the Deye combiner box to run parallel cables to the inverter from the single 50mm output of the MV battery to achieve maximum charge and discharge of the inverter.

MV Battery Transport and Fixing

For balanced transportation, pick up the MV cabinet from the FRONT and REAR only do not pick up from the side.

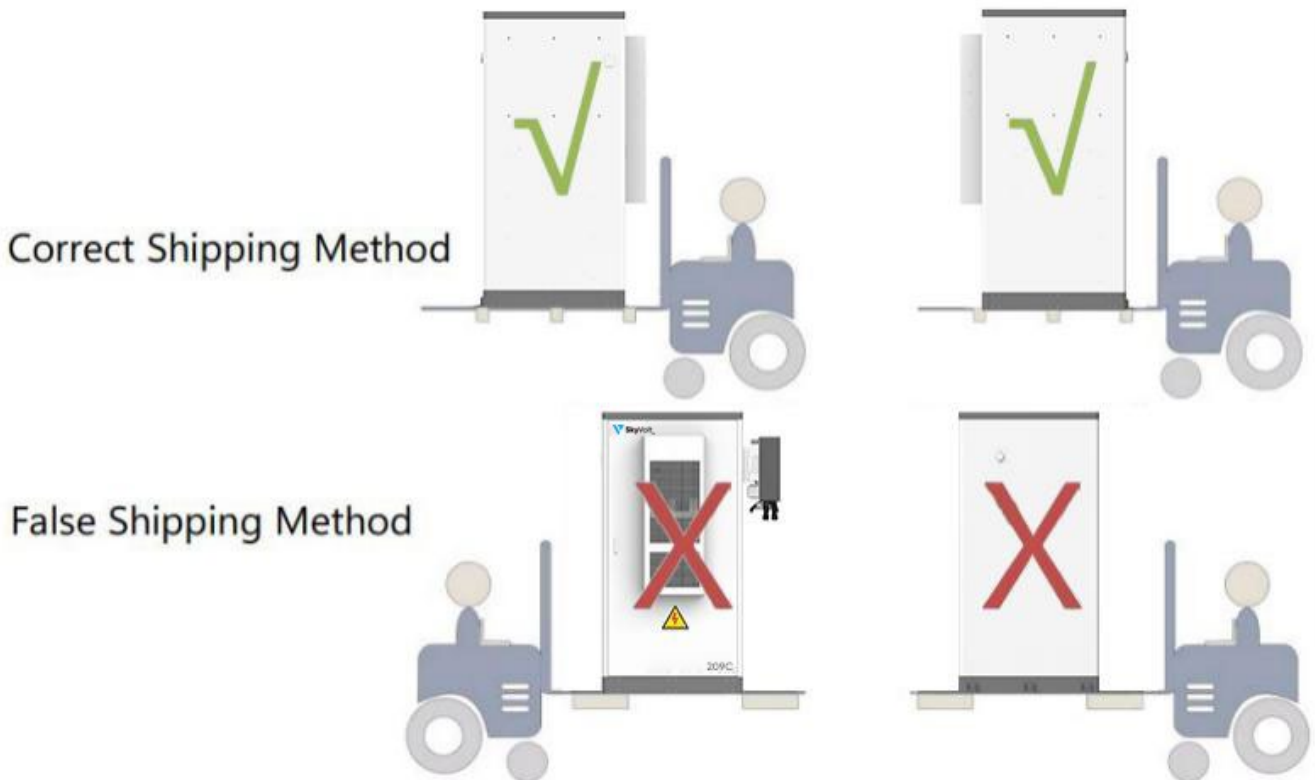

Remove side panels around bottom for forklift access to remove cabinet from pallet.

- To run cables from inside to out of battery cabinet
- To fix cabinet to concrete slab (M8 with washers to M16 fixings recommended)

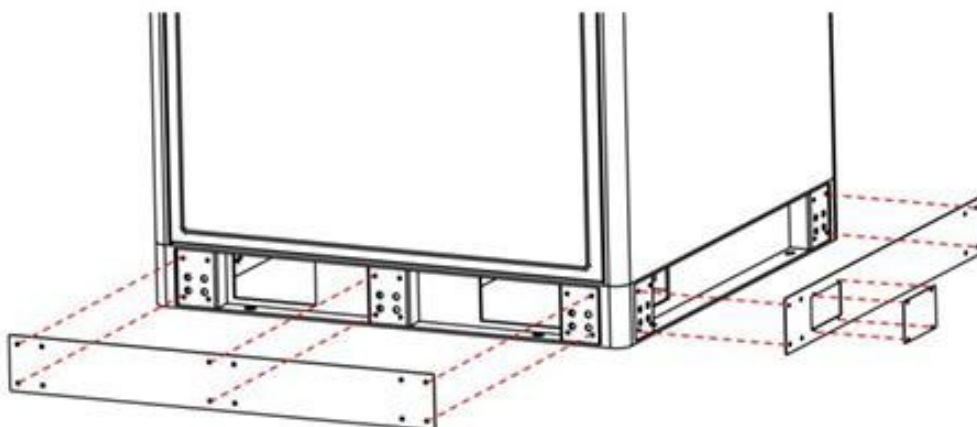

MV Battery Installation Location

Minimum space requirement around the cabinet for correct installation and maintenance:

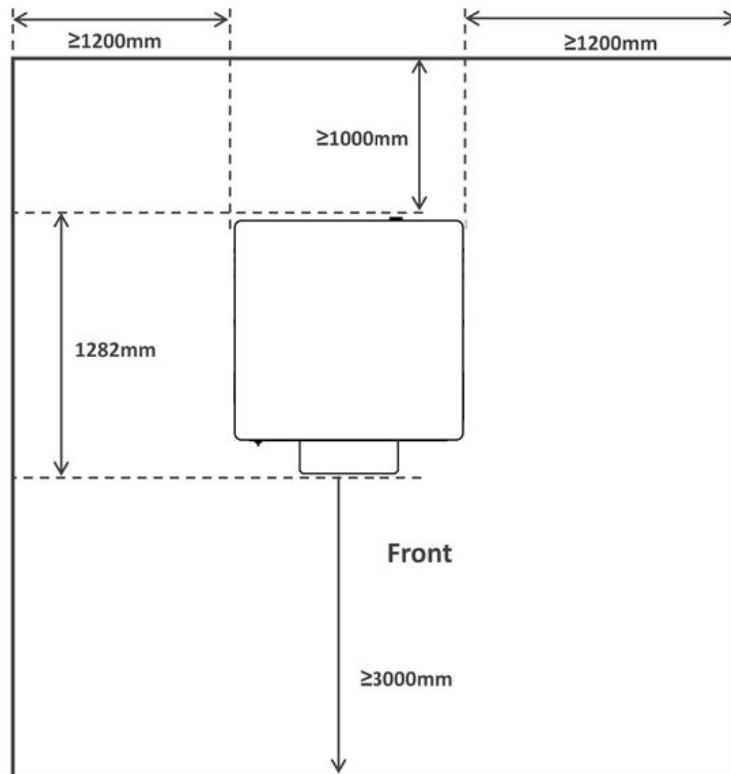

Multiple MV cabinet installation spacing:

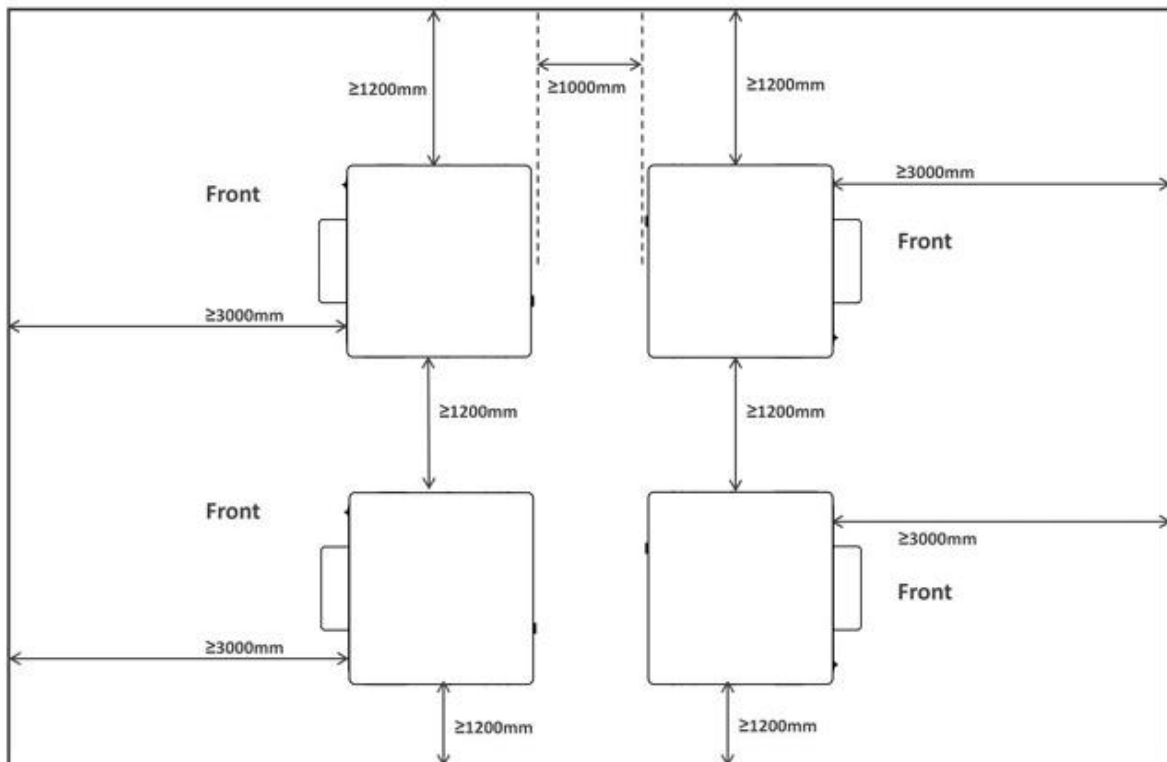

See next page regarding installation against a wall (no 1000mm space).

MV Battery System Example Layout

This is an example layout for the MV cabinet connecting to the combiner box and 1 x Deye HV inverter.

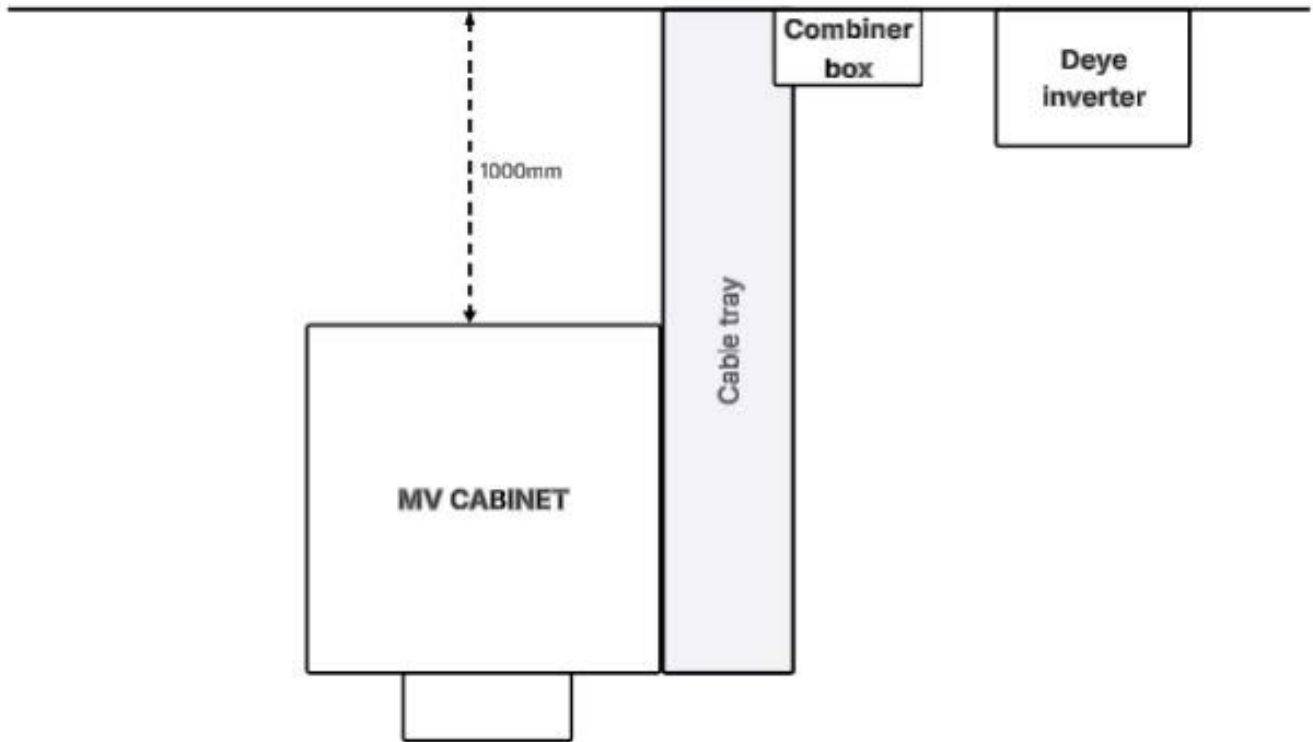

The 1-meter spacing as stated in the manufacturer's installation guide is in reference to GB 51048-2014 Code for Design of Electrochemical Energy Storage Power Station.

Safety clearance settings shall comply with local implementation standards.

If Australian standards allow you may install this MV cabinet against a wall.

BMS Cable Connection

A BMS cable is provided with the MV cabinet but for compliance we recommend running pink cat 5 cable (or suitably rated) and following the below pin out guide.

Battery side – Standard type A pinout – Connects to PCS port

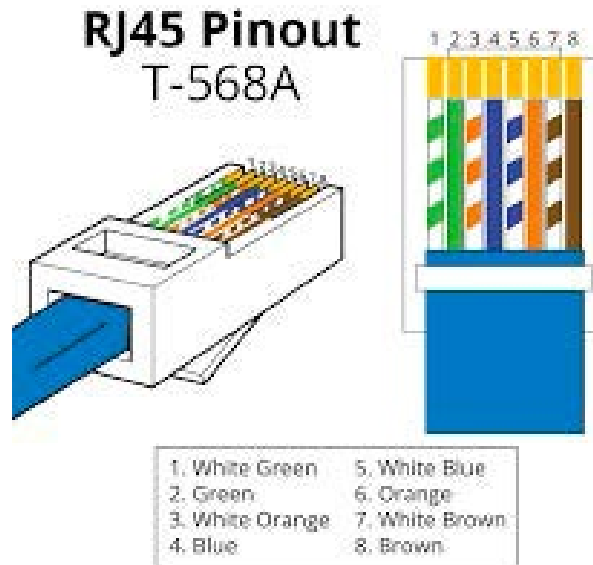

Inverter side - (For Deye 29 – 50kW Inverters) - Connects to BMS 1 port

Connect ONLY pins 4 and 5 to avoid cross communication.

No.	Color	BMS1	BMS2	Meter	RS485	DRM
1	Orange&White	485_B	485_B	485_B	485_B	DRM1/5
2	Orange	485_A	485_A	485_A	485_A	DRM2/6
3	Green&White	GND_485	GND_485	GND_COM	GND_485	DRM3/7
4	Blue	CAN-H1	CAN-H2	485_B	—	DRM4/8
5	Blue&White	CAN-L1	CAN-L2	485_A	—	REF-GEN/0
6	Green	GND_485	GND_485	GND_COM	GND_485	GND_LCD
7	Brown&White	485_A	485_A	—	485_A	NetJ1_7
8	Brown	485_B	485_B	—	485_B	NetJ1_7

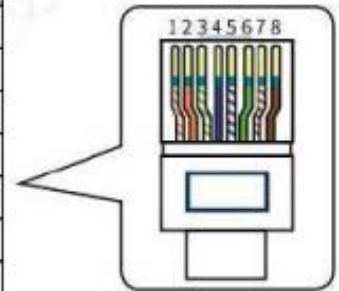

MV Cabinet Start – Up

With the DC links, BMS and earth cables connected start up is:

1. Rotate the HV isolation switch to "ON" position.
2. Press "Start" button.
3. Reverse these steps for shutdown.
4. If the inverter has not yet been commissioned, it will throw the standard alarms on start-up. Follow these next steps for basic commissioning of the Deye inverter.

Inverter Commissioning

Start up system

1. Turn ON battery system.
2. Press the ON button on left side of inverter.
3. Turn ON PV array isolator (this can be done end of commissioning).

Settings

1. Press the cog wheel top right of the screen to enter the settings menu.
2. Some Inverters require installer code = 7777 Enter when prompted.
3. Advanced Function: Lock out all changes = Untick (code 7777).
4. Disable DRM – Press tick bottom right of the screen to save.

Basic Settings

Set Time and Date of site – Press the tick bottom right of the screen to save.

Battery Settings Page 1

1. Battery mode = Lithium Active battery = Yes.
2. Parallel battery = YES (When both battery terminals are used on the inverter).
3. Batt capacity = 314Ah (MV battery).
4. Max charge = Maximum setting the inverter will allow.
5. Max Discharge = Maximum setting the inverter will allow. Press tick bottom right of screen to save.

Battery Settings Page 3

1. Lithium mode 00 Shutdown = 10%
2. Low Batt = 15%
3. Restart = 15%
4. Press tick bottom right of the screen to save.

Grid Settings

1. Grid mode = typically Australia A (State/DNSP dependent) Installer code 7777.
2. Press tick bottom right of the screen to save.

System work mode page 1

1. "Zero export to CT" (on grid) This is important, it makes sure power is fed to line and load side. Or "zero export to load" - This is for off grid (Inverter becomes the meter).
2. Tick 'Solar sell" next to "Zero export to CT" to enable export.
3. Set "Max sell power" to export limit.
4. Energy pattern = Batt first Press tick bottom right of the screen to save.

System work mode page 2

Tick "Time of use" up the top Set "Batt %" to the minimum for batteries to discharge too in all time periods (typically 20%) Press tick bottom right of the screen to save.

Off-grid

Use these settings for a generator:

Gen port use

1. Select "Generator input" Set "Rated power" to the maximum output of the Generator
– E.G: (60kVa generator) x (power factor 0.8) = 48kW
2. This will be the maximum power drawn from the generator to cover loads AND charge batteries.

Battery Settings Page 2

1. Enable Gen charge if off grid (Gen charge + Gen signal)
2. Set battery % to start at (E.G - 20%)
3. A = Amps to charge batteries
4. this is DC not AC
E.G: (Battery current – 50A) x (Battery voltage – 665.6VDC) = 33.2kW drawn from generator

System Check

1. Press the battery symbol on the inverter touchscreen.
 - Select Li-BMS at the bottom right of the screen.
 - It should display BSL (or your battery type) to confirm battery communication.
2. If not, please check the battery comms wiring.
3. Press the solar panel symbol on the inverter touchscreen.
4. Check voltage and current of strings attached to Deye Inverter.
5. Look at the overview for solar generation, loads, and battery charge/discharge.
6. Check power flow is correct, if not check CT direction or try swapping.

Wi-Fi Connection and Support

Call your partner sales manager or our number for technical assistance or Wi-Fi connection support.

1300 787 488



SKYENERGY.COM.AU