



HV Stacked Battery System



User Manual 2026

This document is copyrighted by Sky Energy Production Pty Ltd

Note:

The products and services you purchase shall be subject to the commercial contracts and terms of Sky Energy Production Pty Ltd. All or part of the products and services described in this document may not be within your purchase or usage scope. Unless otherwise agreed in the contract, BSL New Energy makes no express or implied representations or warranties regarding the content of this document.

This document is subject to periodic updates due to product version upgrades or other reasons. Unless otherwise agreed, this document is for informational purposes only. All representations, information, and recommendations contained herein are not warranties of any kind, express or implied.

Safety Note

1.1 Safety symbol description	5
1.2 General safety	5
1.3 Personal safety	6-7
1.4 Battery leakage treatment measures	8
1.5 Electrical safety	9
1.5.1 Conventional requirements	9
1.5.2 Wiring requirements	9
1.5.3 Grounding requirements	9
1.5.4 Maintenance requirements	10
1.6 Mechanical safety	10
1.7 Maintenance and replacement	10-11

Product Introduction

2.1 Product overview	12
2.2 Model description	12-13
2.3 Product appearance	13
2.4 Product parameters	14-15
2.5 Product details	16-17
2.6 Product application	17

Product Installation

3.1 Storage before installation	18
3.2 Pre-installation inspection	18
3.3 Installation environment	18-20
3.4 Prepare tools	21-22
3.5 Mechanical installation	22-25
3.6 Electrical connection	25
3.6.1 Single battery system	26
3.6.2 Cluster battery system	26
3.6.3 Power line connection	27-29

3.6.4 Communication line connection	29-30
3.6.5 Protection ground connection	31
3.6.6 Circuit breaker protection cover	31
3.6.7 Electrical system connection	31
Operation and Maintenance	
4.1 Pre-power on inspection	32
4.2 Startup steps	33
4.3 Shutdown steps	34
4.4 Mobile APP	34-36
4.5 PC cloud platform	36
4.6 Battery display screen	37
4.7 Battery fault handling	37-39
4.8 Patrol and maintenance	39
4.9 Upper computer monitoring	40
Warranty Service	
5.1 Warranty period	41
5.2 Warranty scope	41
5.3 Exemption Statement	41
Appendix	
6.1 Appendix A-Symbol Description	42
6.2 Appendix B-System Connection Diagram	43
6.3 Appendix C-System Connection Diagram	44

Safety Note

1.1 Safety symbol description

When installing, operating and maintaining the equipment, please read this manual first and follow all safety precautions indicated on the equipment and in this manual. To ensure better use of this product and personal and property safety, please read the following symbols carefully.



Danger: indicates a high potential risk that will result in death or serious injury if not avoided.



Warning: indicates moderate potential danger, if not avoided, could result in death or serious injury.



Note: indicates a low potential hazard that, if not avoided, could result in moderate or minor injury to personnel.



Explain: Emphasis and supplementation of content may also provide techniques for optimizing the use of products.

1.2 General safety



Explain:

This equipment should be used in an environment that meets the design specifications, otherwise it may cause equipment failure, and the resulting abnormal equipment function or damage to parts, personal safety accidents, property damage, etc. are not covered by the equipment quality warranty. Local laws, regulations and codes should be observed when installing, operating and maintaining the equipment. The safety precautions in this manual are only supplementary to local laws, regulations, and codes. The Company shall not be liable in the event of any of the following.

1. Installation and use of the environment beyond the provisions of the relevant international, national and regional standards.
2. Do not run in the use conditions described in this manual.
3. Unauthorized disassembly, change the product or modify the software code.
4. Failure to operate the product in accordance with the operating instructions and safety warnings in the product and documentation.
5. Damage to the equipment caused by abnormal natural environment (force majeure, such as earthquakes, fires, windstorms, floods, mudslides, etc.).
6. The customer did not follow the transportation and installation requirements resulting in damage.
7. Storage conditions do not meet the product documentation requirements caused by damage.
8. Due to customer negligence, incorrect operation or intentional damage to the equipment hardware or data damage.
9. Damage to the system caused by a third party or the customer, including damage caused by relocating and installing the system that does not meet the requirements of this manual, as well as adjusting, changing or removing identification marks that do not meet the requirements of this manual.
10. Defects, failures or damages caused by acts, events, negligence or accidents beyond the seller's reasonable control, including power outages or electrical failures, theft, war, riots, civil commotion, terrorism, willful or malicious damage.



Danger:

The equipment has a high voltage, and non-standard operation may cause electric shock or fire, resulting in death, serious personal injury or serious property loss. Please comply with the operation sequence and safety precautions given in this manual and other relevant documents, and operate in a standardized manner:

1. Please check the cable connections of the pre-installed equipment. Check if the equipment is damaged, such as holes, dents or other signs of possible internal damage. Check that the internal components of the equipment are not displaced, and do not change the structure, installation sequence of the equipment without authorization.
2. Do not clean the electrical parts inside the equipment with water. If you find that liquid enters the equipment, press the emergency stop switch immediately, and notify the on-site management personnel.
3. Installation, wiring, maintenance and replacement operations shall be prohibited while energized. Before contacting any conductor surface or terminal, the voltage of the contact point shall be measured, and the protective ground of the equipment or parts requiring maintenance shall be reliably grounded to confirm no electric shock hazard.
4. Except for the personnel who operate the equipment, other personnel should not approach the equipment. Do not power on the equipment without completion of installation or confirmation by professional personnel. When the equipment is powered on for the first time or the main circuit is energized for operation, at least two personnel must be on site.



Explain:

1. The operation behavior and operation tools of users in the process of transportation, handling, installation, wiring and maintenance shall comply with the laws, regulations and relevant standards of the countries and regions where they are located.
2. Reverse engineering, decompiling, disassembling, adapting, implanting or other derivative operations of the equipment software are prohibited. No research on the internal implementation of the equipment, acquisition of the source code of the equipment software, theft of intellectual property rights or disclosure of any results of performance testing of the equipment software are allowed in any way.

1.3 Personal safety



Danger:

1. During the operation of the equipment, appropriate personal protective equipment should be worn. If you find a fault that may lead to personal injury or equipment damage, you should immediately terminate the operation, report to the person in charge, and take effective protection measures.
2. Before using tools, please master the correct use of tools to avoid injury and damage to equipment.
3. During the operation of the equipment, part of the internal shell temperature is high, there is a danger of burns, please do not touch.
4. To ensure personal safety and normal use, it should be reliably grounded before use.

5. When the battery module malfunctions, the temperature may exceed the burn threshold of the touchable surface, and contact should be avoided.
6. Do not open or damage the battery module, the released electrolyte is harmful to skin and eyes, contact should be avoided.
7. Do not place extraneous objects on the top of the device or insert them anywhere in the device.
8. Do not place flammable objects around the equipment.
9. The battery is strictly prohibited to be placed in the fire, so as not to explode, endangering personal safety.
10. Do not place the battery module in water or other liquids.
11. Do not short the battery module docking terminals, battery shorting will cause combustion.
12. The battery may cause electric shock and the danger of large short-circuit current.
13. Do not use water or detergent to clean the internal and external electrical parts of the device.
14. Do not stand or lean on or sit on the equipment.
15. Do not damage the modules of the device.
16. When installing the battery module, if the battery module is dropped or strongly impacted, it will cause damage to the equipment, and it is strictly prohibited to continue using the equipment, otherwise, it will be a safety risk (there may be liquid leakage from the battery cell, electric shock injury, etc.).



Warn:

1. Remove watches, rings or other metal objects.
2. Use tools with insulated handles.
3. Wear rubber gloves and boots.
4. Do not place small tools or metal parts on top of the battery module.
5. Disconnect charging power before connecting or disconnecting battery terminals.
6. Determine if the battery is accidentally grounded. If accidentally grounded, remove power from the ground. Contact with any part of a grounded battery may result in electric shock. This possibility of electric shock can be reduced if these grounds are removed during installation and maintenance

1.4 Battery leakage treatment measures



Note

In case of electrolyte leakage, the following emergency measures can be taken according to the severity of leakage.

1. Ensure adequate ventilation and remove all ignition sources.
2. Quickly evacuate the personnel to a safe area, away from the leakage area and in the direction of the upwind.
3. Use personal protective equipment to avoid inhalation of steam, smoke, gas or dust.
4. Take measures to prevent further leakage or overflow in the event of safety.
5. When there is a small amount of leakage, dry sand or inert adsorption materials can be used to absorb the leakage. When there is a large amount of leakage, embankment control is required.
6. Attachments or collected materials should be stored in appropriate sealed containers and disposed of according to local relevant laws and regulations.
7. Remove all ignition sources and use fire extinguishing tools and anti-violence equipment.



Danger

In the event of a leak, avoid contact with the leaking liquid or gas. The electrolyte is corrosive and contact may cause skin irritation and chemical burns. If contact with the battery electrolyte is made, the following measures need to be taken

1. Inhalation: Evacuate the contaminated area, immediately transfer to fresh air, keep breathing; if breathing difficulties, give oxygen; if the patient ingested or inhaled the substance, shall not be mouth-to-mouth artificial respiration; if breathing stops. Immediately perform cardiopulmonary resuscitation; and immediately seek medical help.
2. Eye: Immediately flush eyes with plenty of water for at least 15 minutes, do not rub, and seek medical help immediately.
3. Skin: Remove contaminated clothing immediately, wash skin contact area with plenty of water and soap, and seek medical help immediately.
4. Ingestion: Prohibit induced vomiting, do not feed the unconscious person anything from the mouth, and seek medical help immediately.
5. Protection of First Aiders: Ensure that healthcare workers understand the hazardous properties of the product and take their own protective measures to protect themselves and prevent the spread of contamination.

1.5 Electrical safety

1.5.1 Conventional requirements



1. All electrical connections must meet the electrical standards of the country/region where it is located.
2. must obtain the permission of the power department of the country / region to be connected to the grid to generate electricity.
3. The user's own cable should meet the requirements of local laws and regulations.
4. Please use special insulated tools for high voltage operation.



Danger: Before making electrical connections, please make sure the equipment is not damaged, otherwise it may cause electric shock or fire.

1.5.2 Wiring requirements

1. Please choose the cable that meets the requirements of local laws and regulations. Similar cables should be tied together, different types of cables should be laid separately, and they should not be wound or crossed with each other.
2. The cables used in the cabinet must be firmly connected, well insulated and in good specification. The cable passing through the pipe or through the line hole must be protected to avoid damage by sharp edges, burrs and so on.
3. Cable use in a high temperature environment may cause insulation layer aging and damage. The distance between cable and heat generating device or heat source area peripheral should be at least 30mm.
4. In order to ensure the safety of construction, all cables should be laid and installed above 0°C , and should be handled gently when moving cables, especially in a low temperature environment



Danger: Do not install or remove power lines while they are energized. The power line core will produce electric arc or spark when it comes into contact with the conductor, which can cause fire or personal injury.

1.5.3 Grounding requirements

1. When installing equipment that needs to be grounded, the protective ground wire must be installed first; when removing equipment, the protective ground wire must be removed last.
2. Do not damage the grounding conductor.
3. Do not operate the equipment without installing the grounding conductor.
4. The equipment should be permanently connected to the protective ground. Before operating the equipment, the electrical connection of the equipment should be checked to ensure that the equipment has been reliably grounded.

1.5.4 Maintenance requirements

1. Before connecting or removing the cable, the protection switch of the corresponding circuit must be disconnected first.
2. Use the multimeter of corresponding voltage level to check whether it is energized and ensure that the equipment has been completely powered off.
3. If there are charged objects nearby, use insulating board or insulating tape to shield or wrap.
4. After the grounding line is used to reliably connect the circuit to be repaired with the grounding circuit, operation and maintenance shall be carried out.



Explain

1. Before connecting the cable, you must first confirm that the cable label is correct before connecting.
2. If the equipment has multiple input channels, all the input channels of the equipment should be disconnected, and the equipment can be operated after the equipment is completely powered off.
3. After the overhaul is completed, remove the grounding wire between the overhaul circuit and the grounding circuit.

1.6 Mechanical safety

1. When carrying equipment by hand, you should prepare for bearing weight, wear protective gloves, wear anti-shock shoes and other safety protective equipment.
2. Move the equipment carefully during the equipment transportation process to avoid impact or fall. Avoid scratching the surface of the equipment, damaging parts or cables.
3. When transporting equipment, the volume of equipment may cover the sight of the operator, so auxiliary personnel should be arranged to assist in completing the task.

1.7 Maintenance and replacement

Please maintain the equipment under the condition of familiarizing and understanding the contents of this manual and having appropriate tools and test equipment.

1. Before maintenance, please power off the equipment, and then wait for the corresponding time according to the instructions of the delayed discharge label to ensure that the equipment has been powered off, and then operate the equipment
2. During the maintenance process, please try to avoid irrelevant personnel entering the maintenance site, and temporary warning signs or fences must be erected for isolation.
3. If the equipment fails, please contact your dealer in time to deal with it.
4. The equipment can only be re-powered after the fault is handled, otherwise it may cause the fault to expand or damage the equipment.
5. Unauthorized persons should not open the cover plate without authorization, otherwise there is a risk of electric shock, and the resulting failure is not covered by warranty.
6. Operation and maintenance personnel and professional technicians should be

trained in safe use and equipment maintenance, and should operate under sufficient preventive measures and personal protective equipment.

7. When it is necessary to move or reconnect the wiring, the power input must be cut off and the machine must be waited for 5 minutes before the energy inside the machine is released. After using the multimeter to confirm that there is no dangerous voltage on the DC bus and inside the machine to be repaired, maintenance can begin.
8. Battery maintenance shall be performed or supervised by personnel familiar with the battery and the preventive measures required for it.
9. When replacing the battery, please replace the same type of battery module.
10. After maintenance operation, check immediately to ensure that no tools or other parts are left in the equipment.
11. If the equipment is not used for a long time, the battery and recharging need to be stored according to this manual.



Danger

During the operation of the equipment, there is a risk of electric shock which may result in death, serious personal injury or severe property damage. Therefore, before performing any maintenance work, the equipment must be powered off and the safety precautions listed in this manual and other relevant documents must be strictly followed.

Product Introduction

2.1 Product overview

The battery system consists of a combination of battery modules and a high-voltage control box, designed for home energy storage systems; with high-voltage DC input and output ports, it is capable of storing and releasing high-voltage DC power according to the needs of photovoltaic energy storage.

2.2 Model description

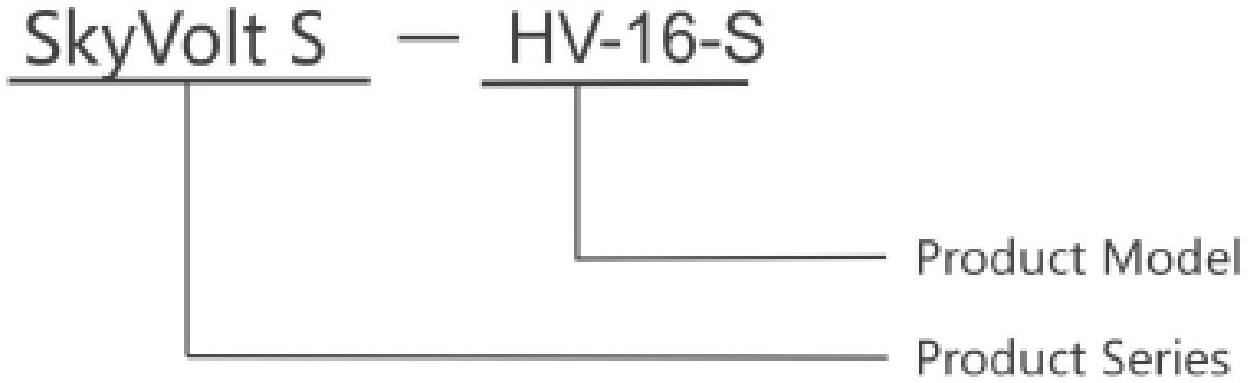

Graph 2.2-1

Explanation: The SkyVolt S series high-voltage stacked battery system can freely combine according to the number of battery PACKs and the power of specific inverters, thereby achieving flexible configuration of AC rated output power; and supports up to 5 groups of the same model SkyVolt S HVS for cluster use.

Serial No.	Meaning	Explain
1	Product model	7 HV-10/16/21/26/32/37-S; Capacity of battery PACKs
2	Product features	7 SkyVolt S HVS: High voltage battery system

Table 2.2

HV-16-S/HV-21-S/HV-26-S:

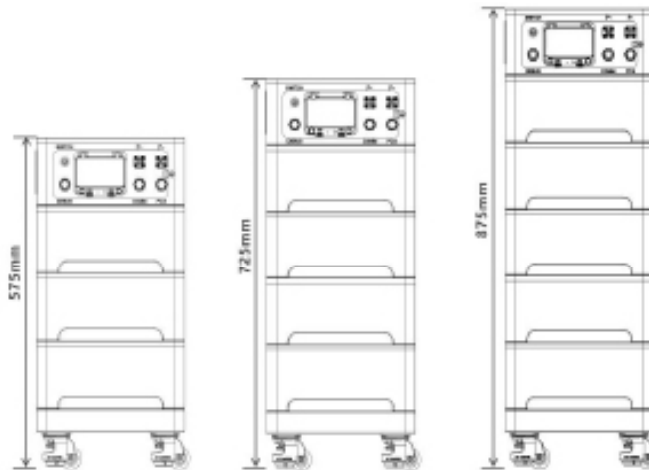

Graph 2.2-2

HV-32-S/HV-37-S:

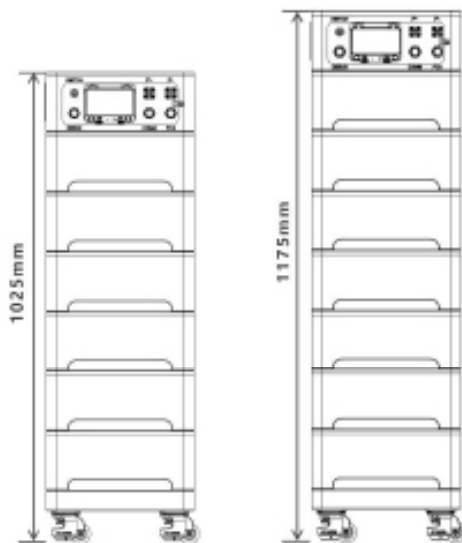

Graph 2.2-3



Explain

1. The actual height may vary slightly, please take the actual installation height as the standard;
2. Only up to 8 battery modules are supported.

2.3 Product appearance

SkyVolt S HV-26-S



Graph 2.3



Note: The configuration of different projects is different, and the actual shipment is the basis.

2.4 Product parameters

SkyVolt S Technical Parameter Table

General Parameter	HV-16-S	HV-21-S	HV-26-S
Rated voltage	307.2V	409.6V	512V
Rated capacity	52Ah	52Ah	52AH
Cell brand (LFP-3.2V)	REPT52Ah	REPT52Ah	REPT52AH
System configuration	96S1P	128S1P	160S1P
System composition	3 pack+1 control box	4pack+1 control box	5pack+1 control box
Rated power	15.97kWh	21.29kWh	26.62kWh
Charge upper voltage	340.8V	454.4V	568V
Discharge lower voltage	273.6V	364.8V	456V
Recommended current	26A	26A	26A
Maximum charging current	52A	52A	52A
Maximum discharging current	52A	52A	52A
Dimension (W x D x H, mm)	665*370*575	665*370*725	665*370*875
Communication protocol	CANBUS (Baud rate @500Kb/s or @250Kb/s)/Modbus RTU(@9600b/s)		
Host software protocol	CANBUS (Baud rate @250Kb/s)		
Cloud platform	Bluetooth/wifi		
Operation temperature range	Charge:0~55°C/Discharge: -10~55°C		
Cycle life(25°C)	6000@90%DOD		
Protection level	IP65		
Storage temperature	-10°C~40°C		
Storage humidity	10%RH ~90%RH		

Table 2.4-1

REPT52AH	HV-32-S	HV-37-S
Rated voltage	614.4V	718.8V
Rated capacity	52AH	52AH
Cell brand (LFP-3.2V)	REPT52AH	REPT52AH
System configuration	192S1P	224S1P
System composition	6pack+1control box	7pack+1control box
Rated power	31.94kWh	37.27kWh
Charge upper voltage	681.6V	795.2V
Discharge lower voltage	547.2V	645.12V
Recommended current	26A	26A
Maximum charging current	52A	52A
Maximum discharging current	52A	52A
Dimension (W x D x H, mm)	665*370* 1025	665*370* 1175
Communication protocol	CANBUS (Baud rate @500Kb/s or @250Kb/s)/Modbus RTU(@9600b/s)	
Host software protocol	CANBUS (Baud rate @250Kb/s)	
Cloud platform	Bluetooth/wifi	
Operation temperature range	Charge:0~55°C/Discharge: -10~55°C	
Cycle life(25°C)	6000@90%DOD	
Protection level	IP65	
Storage temperature	-10°C~40°C	
Storage humidity	10%RH ~90%RH	

Table 2.4-2



Note: It is not recommended to operate the battery at maximum charge/discharge current for a long period of time; the battery's rated capacity of 52Ah is established at "25°C"; the charge/discharge current and power will change according to the temperature and the SOC of the battery.

2.5 Product details

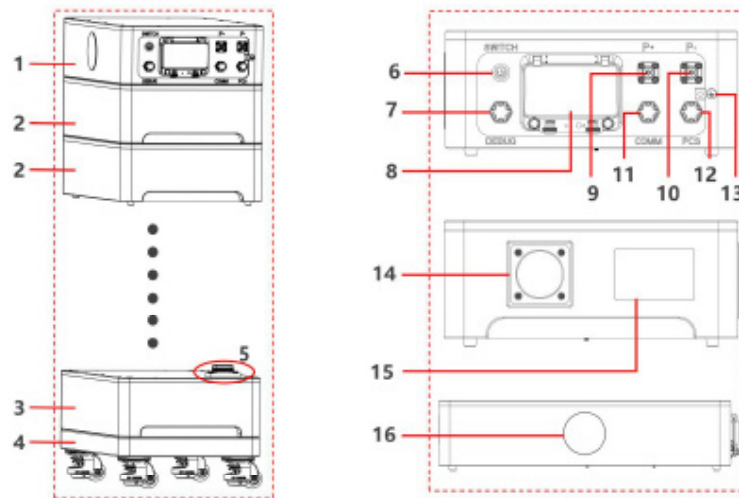

Graph 2.5

Serial No.	Component name	Explain
1	Battery control box	Control the battery system to work
2	Battery module	/
3	Bottom battery module	Only the battery PACK with a public terminal connection
4	Battery base	The base with a roller is easy to adjust the position of the battery
6	Power button	Control the on/off of low voltage circuits in the battery system
7	Debug the port	Used for communicating with the computer, monitoring and upgrading the battery
8	DC circuit breaker	With a protective cover; control the on and off of the high voltage circuit of the battery
9	Battery positive terminal socket	Connect the external positive pole DC cable to the inverter positive pole
10	Battery negative terminal socket	Connect the external negative pole DC cable to the negative pole of the inverter
11	Parallel communication port	The HVS batteries are connected to each other
12	PCS communication port	The battery communicates with the inverter
13	Protective grounding terminal	Connect the battery system protective grounding cable
14	4G & Wifi Antenna	/

15	Battery nameplate	That's the "battery ID"
16	Display screen	Displays battery status information

Table 2.5

2.6 Product application

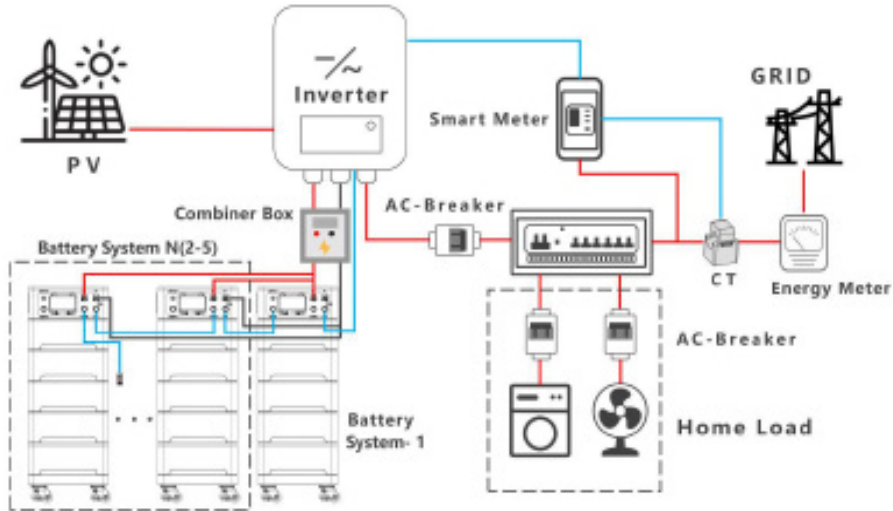

Graph 2.6



Note: The circuit breakers between the inverter and the battery and between the battery system should be installed according to local laws and regulations.

Product Installation

3.1 Storage before installation

1. Preparation before storage: Make sure the outer packing box of the equipment is intact and do not remove it; make sure the desiccant in the box is not lost to keep the interior dry.
2. Storage environment requirements: storage equipment, away from flammable, explosive, corrosive and other items; the equipment will be stored in a cool place, avoid direct sunlight; to ensure that the storage environment is clean, the temperature and humidity range is appropriate, no condensation.
3. Battery storage requirements: the SOC (state-of-charge) range of the storage battery should be 25%~50% SOC; for every 6 months of storage, the battery needs to be charged and discharged for a cycle.
4. Storage temperature range: when the temperature is between $-10\text{ }^{\circ}\text{C}$ and $0\text{ }^{\circ}\text{C}$, the storage time does not exceed 1 month; when the temperature is between $0\text{ }^{\circ}\text{C}$ and $35\text{ }^{\circ}\text{C}$, the storage time does not exceed 1 year; when the temperature is between $35\text{ }^{\circ}\text{C}$ and $45\text{ }^{\circ}\text{C}$, the storage time does not exceed 1 month.
5. Storage humidity range: storage humidity range of 0 to 95% RH, no condensation; if the battery interface is found to have moisture condensation phenomenon, not to install the battery system, should be reasonable treatment.

3.2 Pre-installation inspection

1. Outer package check: verify whether the outer package is intact and undamaged, including whether there are deformation, open holes, cracks or other traces that may lead to damage of the inner equipment.
2. Equipment Model and Deliverables Inspection: Verify whether the equipment model matches the order; confirm whether the type and quantity of deliverables are correct, and check whether the appearance is damaged.

3.3 Installation environment

1. **Installation environment requirements:** equipment shall not be installed in a flammable, explosive, corrosive environment; and the installation location should be to avoid contact with children, and should choose a location that is not easy to accidentally touch; at the same time, pay attention to the surface of the equipment may produce high temperature when running, to prevent scalding.

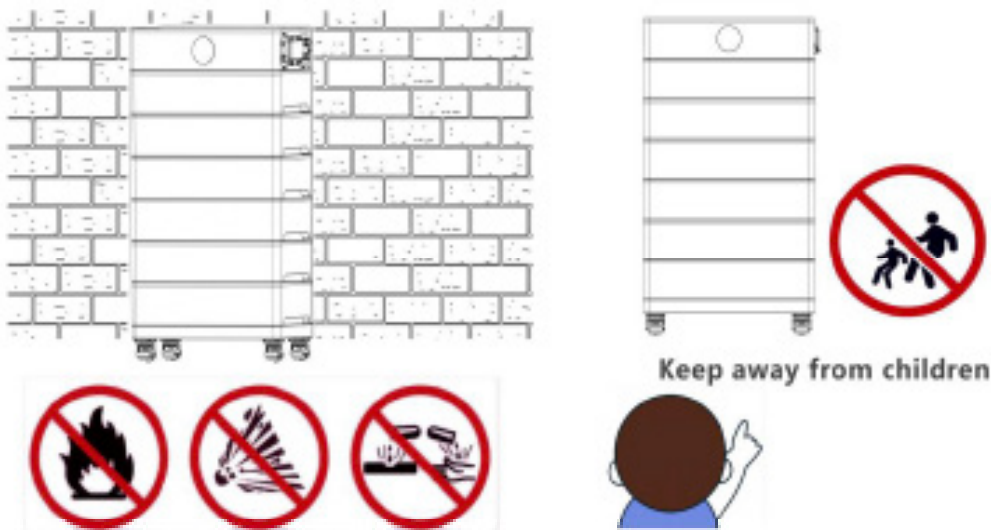

Graph 3.3-1

2. **Installation location notes:** avoid installation in the wall with water pipes, cables and other locations to prevent damage to the battery; The installation environment should be protected from direct sunlight, rain, and snow accumulation. It is recommended to install in a well-ventilated indoor area, and an air-cooled air conditioning system may be installed when necessary.

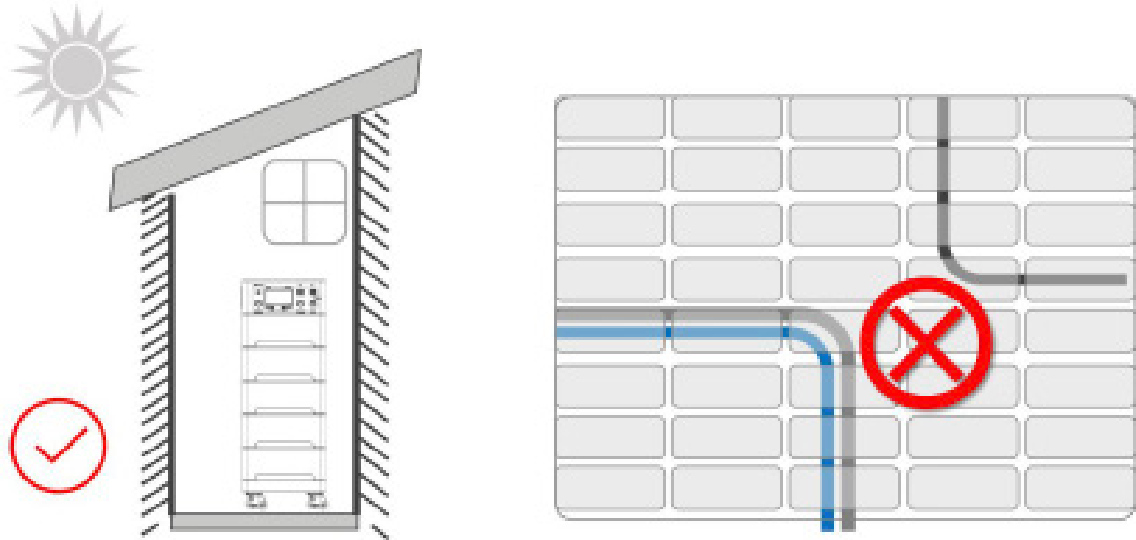

Graph 3.3-2

3. **Installation space and environmental conditions:** Ensure that the installation space meets the ventilation and heat dissipation of the equipment and operating space requirements; the protection level of the equipment is suitable for indoor installation, and the temperature and humidity of the installation environment should be kept within the appropriate range.

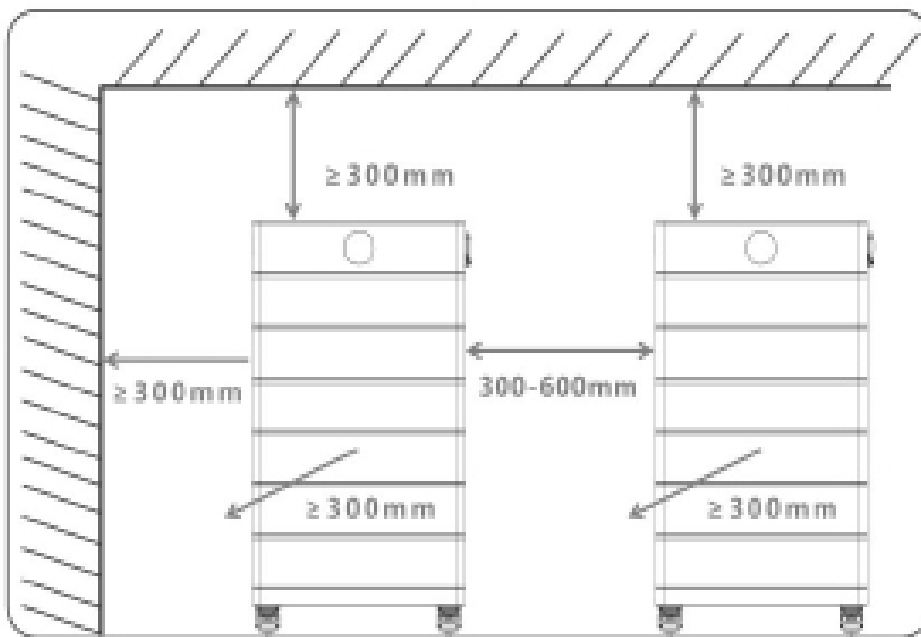

Graph 3.3-3

4. **Equipment installation height and protection:** equipment installation height should be easy to operate and maintain, to ensure that the indicator lights, labels are clearly visible, easy to operate the terminals; equipment installed at an altitude of not more than 2000 meters.
5. **Electromagnetic interference protection:** the installation location should be away from strong magnetic fields to avoid interference; if the installation location near the radio station or wireless communication equipment below 30MHz, the distance between the battery and these devices should be greater than 30 meters.

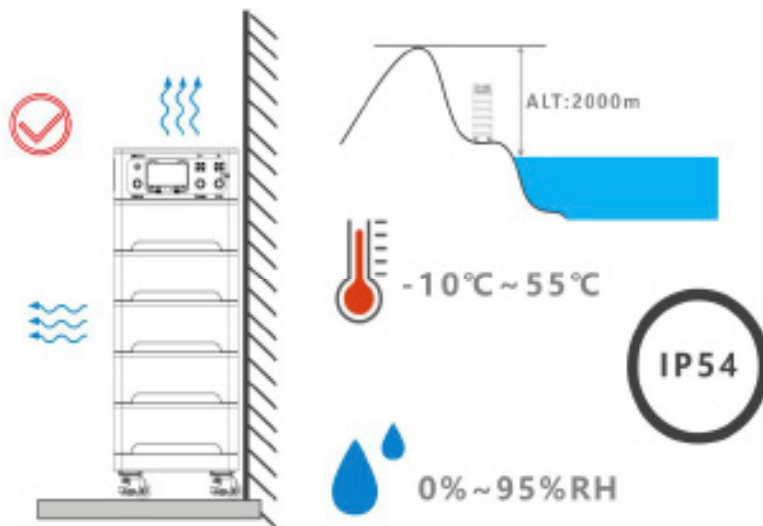





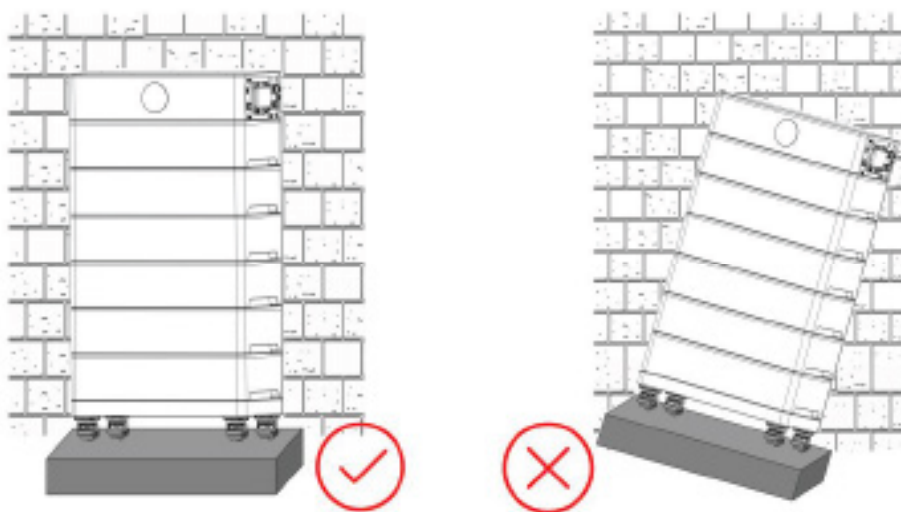





Graph 3.3-4



6. **Installation carrier requirements:** the use of non-flammable materials (such as concrete, masonry or fire treatment of wood metal); carrier needs to be strong, can withstand the weight of the equipment; battery system to be installed against the wall, and add anti-tipping bracket.
7. **Installation angle requirements:** equipment must be installed horizontally, avoid tilting or inverted.



Graph 3.3-5

3.4 Prepare tools

Serial No.	Tool name	Key
1	Insulating gloves	
2	Eye shield	
3	Insulant shoe	
4	Coverall	
5	Safety helmet	
6	Bolt driver	
7	Connection cover cutting pliers	
8	Hydraulic clamp	
9	Heat gun	
10	Multimeter	

11	Torque spanner	
12	Marker pen	



Note: This table is for reference only. The actual tool should be based on local installation standards.

3.5 Mechanical installation



Note:

1. In the process of transportation, handling and installation, local laws and regulations and industry standards must be observed;
2. According to the weight of the battery, the moving personnel should be properly arranged to prevent the injury caused by overweight moving; at the same time, safety gloves must be worn to protect the hands;
3. Please ensure that the battery is kept in balance during transportation to avoid falling.

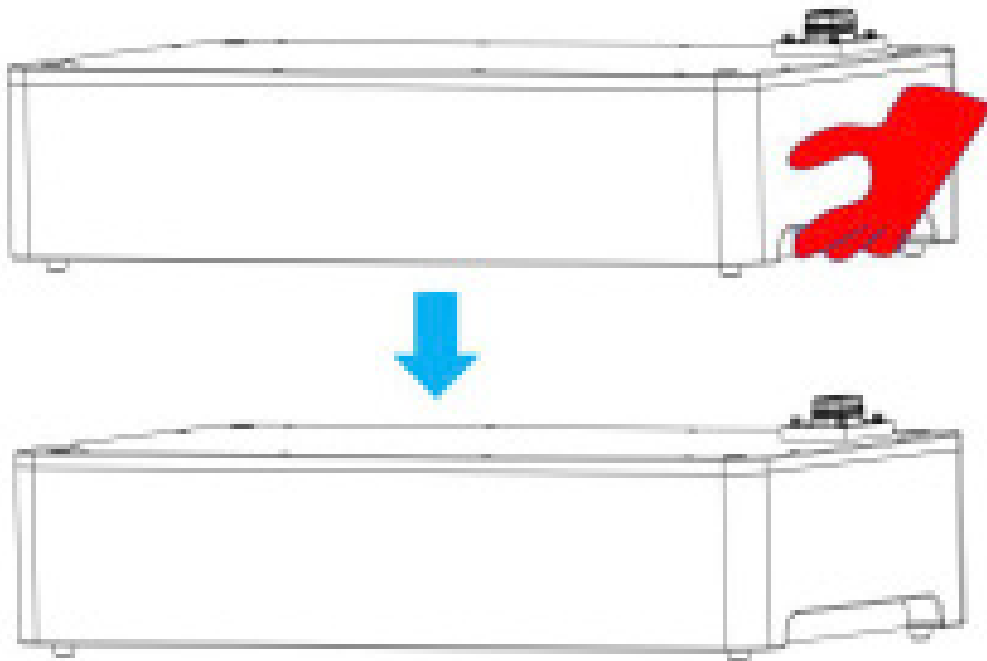

Graph 3.5-1



Note: During installation, ensure that at least two people are involved to ensure safety.

Battery system installation:

Step 1:

Adjust the four pulleys that support the battery base underneath and operate the gears to ensure that the battery base is securely fastened to a carrier of non-flammable material;

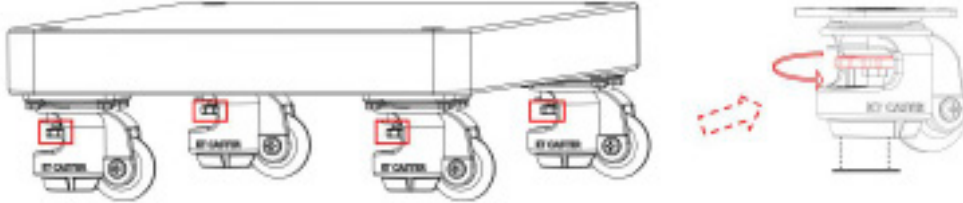

Graph 3.5-2

Step 2:

Place the bottom battery PACK on the base and fix it in the hole in the base through its rubber ground foot to ensure a secure installation;



Note: The bottom battery PACK "has no mother socket at the bottom".

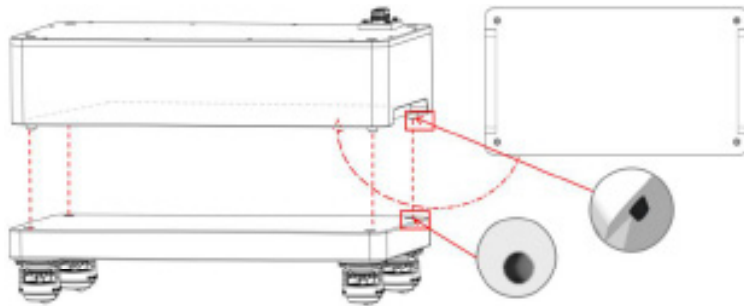

Graph 3.5-3

Step 3:

When stacking the battery PACK, the rubber base of the upper battery should be fixed in the hole of the lower battery, and ensure that the male plug of the lower battery is correctly connected to the female socket of the upper battery;

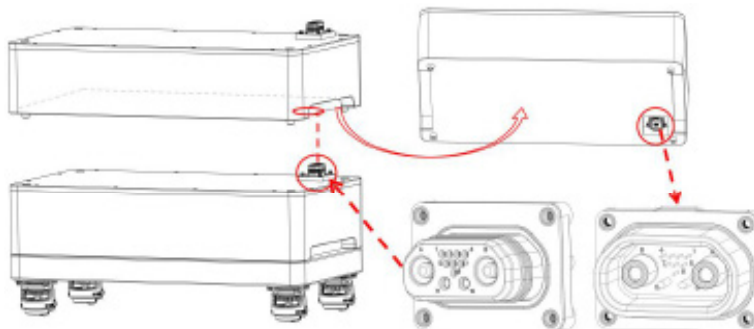

Graph 3.5-4

Step 4:

Repeat step 3 according to the battery model on the delivery list until the required number of battery PACKS are stacked;



Note:

During battery installation, ensure that each HVS battery model contains 3 to 7 battery PACKS and always wear insulating gloves to prevent electric shock.

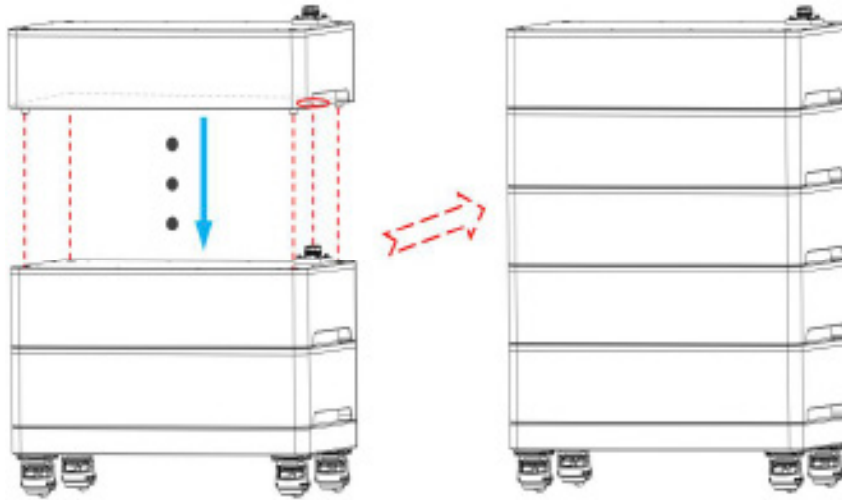

Graph 3.5-5

Step 5:

Similarly, in the HVS battery system, the rubber base of the control box needs to be fixed on the hole position of the lower battery, and ensure that the male plug of the lower battery is accurately connected with the female socket of the upper control box;

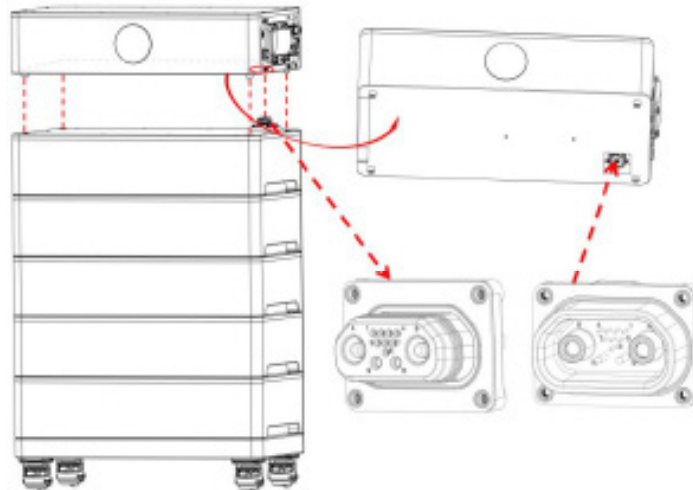

Graph 3.5-6



Note: Ensure that the control box is always positioned above the battery. Do not install the battery on top of the control box. Also, ensure that the holes on the bottom and top are aligned when placing the battery base, battery or control box.

Step 6:

After the installation of the battery system is completed, observe whether it is installed horizontally and firmly. If it is tilted or wobbles, adjust the installation state of the battery system by rotating the adjustment gear

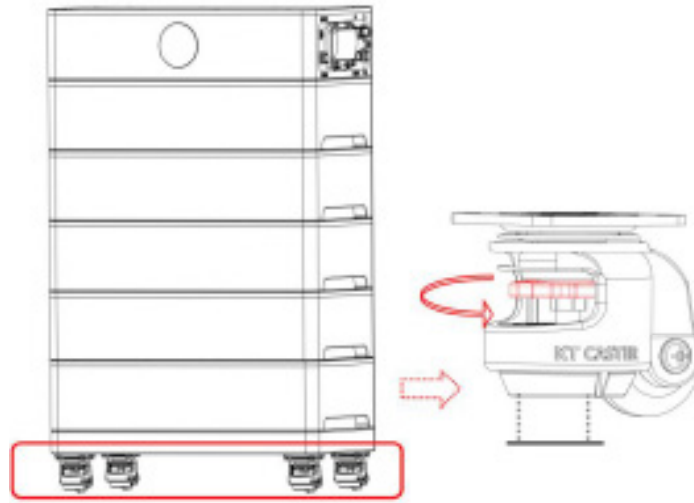

Graph 3.5-7

3.6 Electrical connection



Danger:

1. Safe power off operation

Be sure to completely disconnect the equipment in the battery system before performing any operation on the equipment to prevent electric shock accidents; Strictly comply with the safety precautions in this manual and the safety signs on the equipment;

2. Electrical connection specifications

During the electrical connection process, cables and component specifications that comply with local laws and regulations must be used; The same type of cable should be tied together and ensure that different types of cables are arranged separately to avoid the cables from entangling or crossing each other;

3. Precautions for pressing terminal blocks

When pressing the terminal, it is necessary to ensure that the cable conductor part is fully in contact with the terminal; It is strictly prohibited to press the cable insulation skin together with the terminal, which may lead to the failure of the equipment to operate normally, or heat up during operation due to unreliable connection, and then damage the inverter terminal block.



Note

1. Electrical connection operation is limited to professional personnel;
2. The cable color shown in the figure is only for reference, and should be selected according to the specific situation in practice;
3. Ensure that the cable specifications used comply with local laws and regulations.

3.6.1 Single battery system

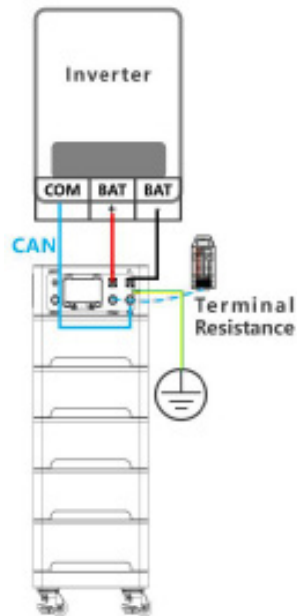

Graph 3.6.1



Note

1. DEBUG port is for debugging, please do not use this port when connecting communication lines;
2. Connect the PCS port to the inverter and install the terminal resistor on the COMM port; note that if the terminal resistor is not installed, the battery system will not work properly.

3.6.2 Cluster battery system

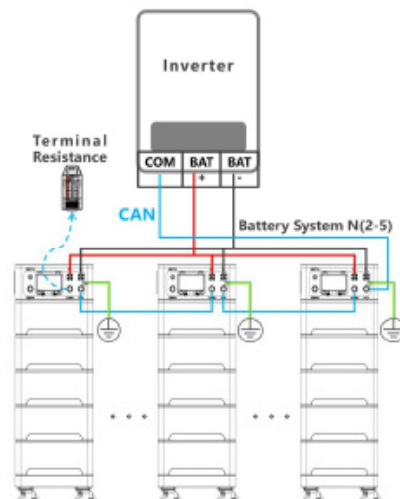

Graph 3.6.2



Note

1. HVS battery system supports up to 5 battery systems for cluster.
2. When performing and clustering, it is necessary to ensure that the available power of each battery system is consistent to ensure the balance and efficient operation of the system;
3. Ensure that the "PCS" communication port of battery system 1 is connected to the inverter, which is used to control and cluster the communication between the battery system and the inverter;
4. Another "COMM" communication port of battery system 1 is applied to battery cluster connection;
5. For battery system N (N indicates the last battery system), it must be ensured that the "COMM" communication port has been installed with terminal resistance;
6. The DEBUG port is for debugging purposes. Please do not use this port when connecting communication lines.



Explain:

The installation of terminal resistors is crucial for maintaining the integrity of communication line signals, preventing signal reflection and attenuation. If the "COMM" port does not have a terminal resistor installed, it may lead to communication abnormalities in the battery system, thereby affecting the overall operation of the energy storage system.

3.6.3 Power line connection

External power connection:

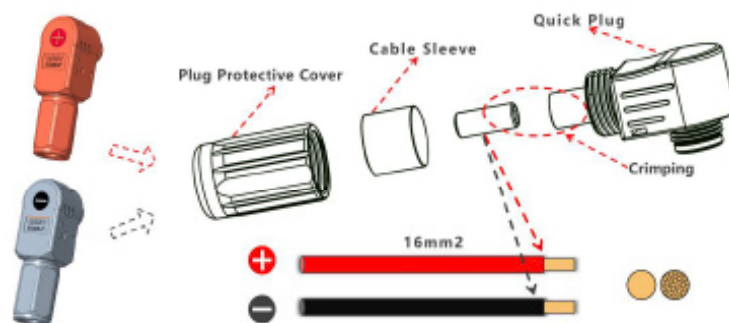

Graph 3.6.3-1



Note: When using this specification of DC cable, only a single battery system is supported.

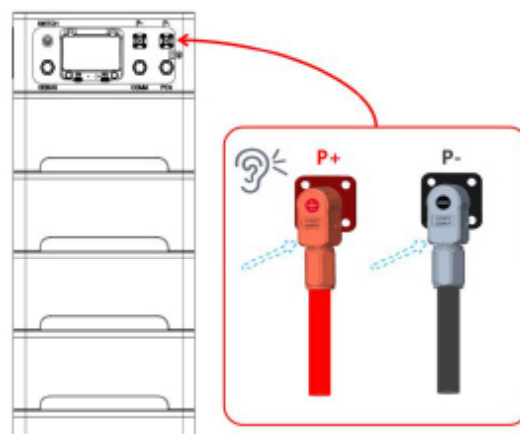

Graph 3.6.3-2

Internal power connection (multi-core mixed connector):

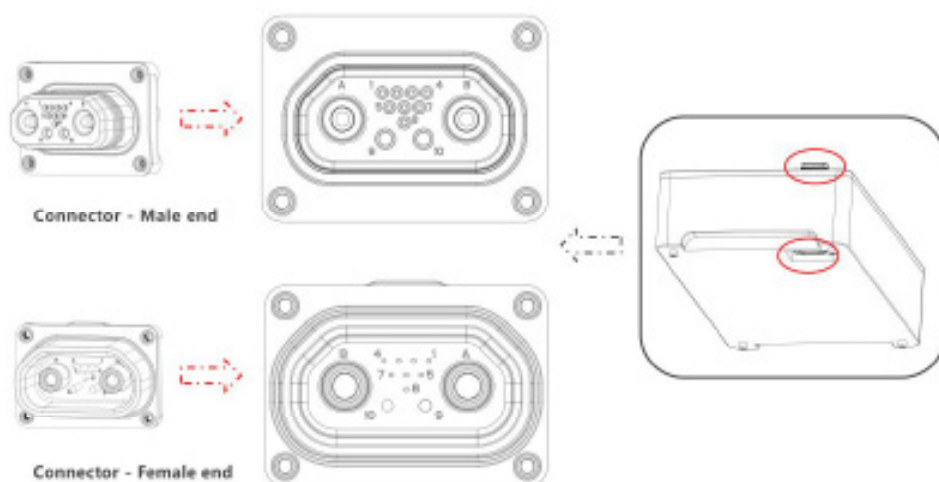

Graph 3.6.3-3

Explain:

1. The protection level of multi-core mixed connector is IP67, and there is a waterproof pad and a waterproof ring inside;
2. Follow the national standards and industry standards for design.

Serial No.	Explain
1	BCU communication output port
2	BCU communication input por
3	The connection between the positive terminal of the mother socket and the negative terminal of the battery PACK
4	The connection between the positive terminal of the public plug and the positive terminal of the battery PACK
5	The connection between the negative pole of the public plug and the negative pole of the mother socket
6	Ground connection of the public plug
7	Grounding connection of the mother socket

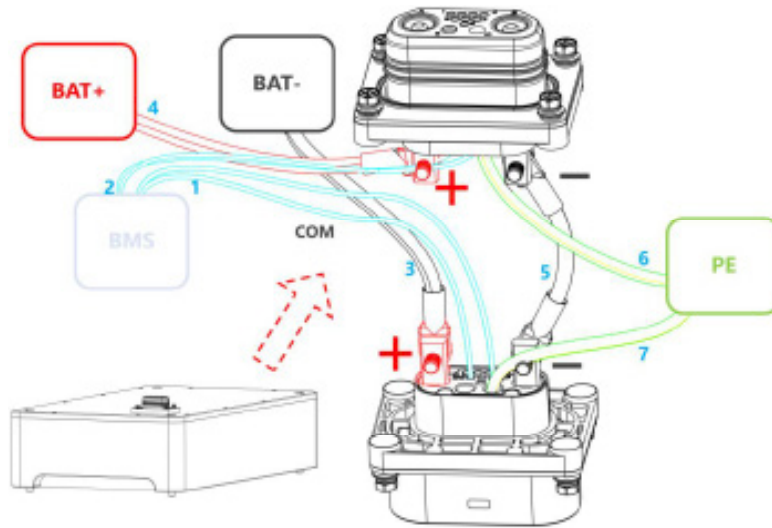

Graph 3.6.3-4



Note: In the HVS battery system, there is only a “male plug” in the bottom battery PACK, which needs to be plugged directly to the positive and negative terminals of BAT “+ and” -” respectively. At the same time, the BCU has only one communication input interface to interact with the external system.

3.6.4 Communication line connection



Note:

1. Users should decide whether to use the communication cable attached to the inverter according to the installation requirements, and refer to the user manual to understand the cable specifications and connection methods;
2. If you want to purchase communication cables by yourself, it is recommended to use standard Ethernet cable and RJ45 crystal connector as the connection solution.

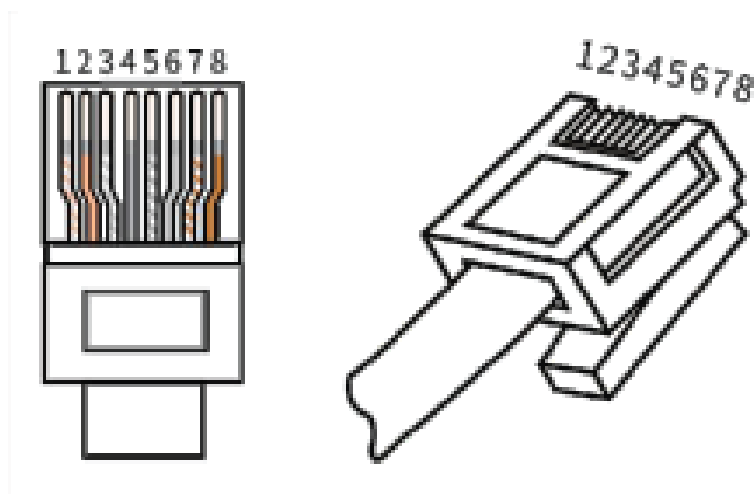

Graph 3.6.4

PIN	DEBUG	PCS	COMM
1	CAN0H	CAN0H	NC
2	CAN0L	CAN0L	NC
3	CAN1_GND	CAN1_GND	CAN1_GND
4	CAN1H	CAN1H	CAN1H
5	CAN1L	CAN1L	CAN1L
6	RS485G_1	DIH_IN2	HSS8
7	RS485A_1	GND	GND
8	RS485B_1	GND	GND

Table 3.6.4-1

Serial No.	Name	Explain
1	CAN0H CAN0L	Function debugging and upgrading
2	CAN1_GND CAN1H CAN1L	Connect the inverter communication or battery cluster communication
3	RS485G_1 RS485A_1 RS485B_1	Connect to external RS485 communication devices
4	DIH_IN2	High level signal input detection, that is, battery cluster signal detection
5	HSS8	High side switch output, that is, cluster signal output
6	GND	Signal ground

Table 3.6.4-2



Note: This chapter only describes the definition of communication port. It is necessary to install battery system terminal resistance to avoid cluster failure and ensure the normal operation of the system.

3.6.5 Protection ground connection



Note:

1. Protective ground wire, recommended specification: Type: outdoor single core copper wire, conductor cross section: 6mm²;
2. Please ensure that the cable is not loose after being pressed in place;
3. After the battery stack is completed, the protective ground line should be connected first to ensure safety, and the protective ground line should be removed as the last step when the battery system is removed.

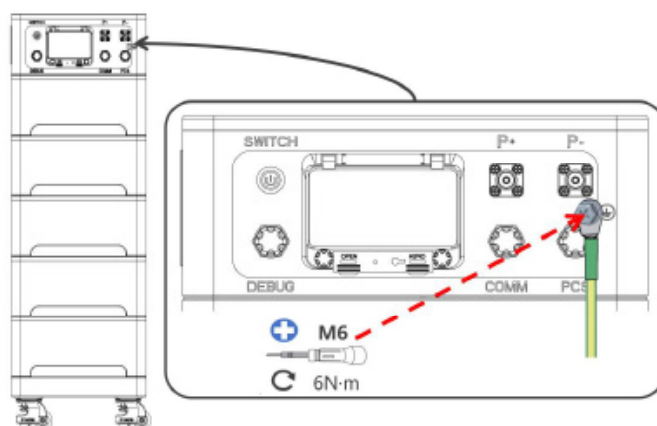

Graph 3.6.5

3.6.6 Circuit breaker protection cover

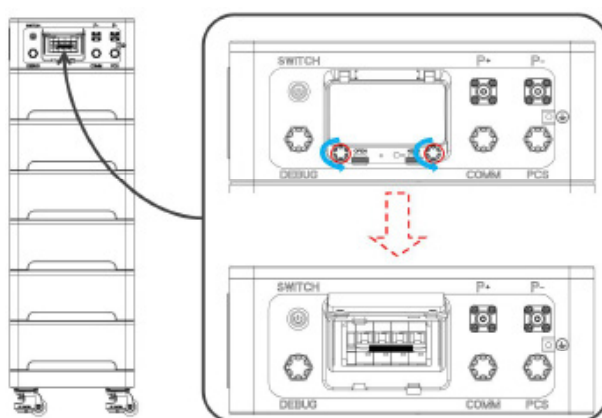

Graph 3.6.6

3.6.7 Electrical system connection



Note: Refer to Appendix B and C.

Operation and Maintenance



Danger:

Use special protective equipment and special insulating tools to avoid electric shock or short circuit fault.

1. During the process of recharging, we should observe the battery while charging. If any abnormal phenomena are found, we should stop charging the battery immediately, find out the cause and solve it before continuing to charge.
2. After the battery installation and adjustment or after the battery discharge is completed, please charge the battery in time, otherwise it may lead to the damage of the battery due to over discharge.

4.1 Pre-power on inspection

Inspection items and acceptance standards

Serial No.	Inspection item	Check criteria
1	The system is installed	Install correctly and firmly
2	Cable layout is reasonable	The cable layout is reasonable to meet the requirements of users
3	The line is tied beautifully	The line should be even and no sharp corners should be left at the cut
4	Reliable grounding	Ground connection is correct and secure
5	Turn off the switch	The inverter and all switches connected to the battery are in the "OFF" state
6	Cable connection is in place	The DC line, AC line and communication line are connected correctly and firmly
7	Seal unused terminals and joints	Unused terminals and interfaces are covered with waterproof covers
8	The installation environment meets the requirements	The installation space is reasonable and the environment is clean and tidy

4.2 Startup steps

Step 1: Use the multimeter to confirm that the grid voltage is within the predetermined range;

Step 2: Close the circuit breaker between the inverter and the battery;

Step 3: Close the battery circuit breaker; the circuit breakers between the battery systems need to be closed in sequence;

Step 4: Press the battery start key "SWITCH"; if it is a cluster system, before the first cluster, be sure that the voltage difference between each battery system does not exceed 5V, then press the start key "SWITCH" between each battery system one by one, and it needs to be stable for 5 minutes;

Step 5: Follow the inverter user manual instructions to perform the power-up operation to start the inverter in the system.

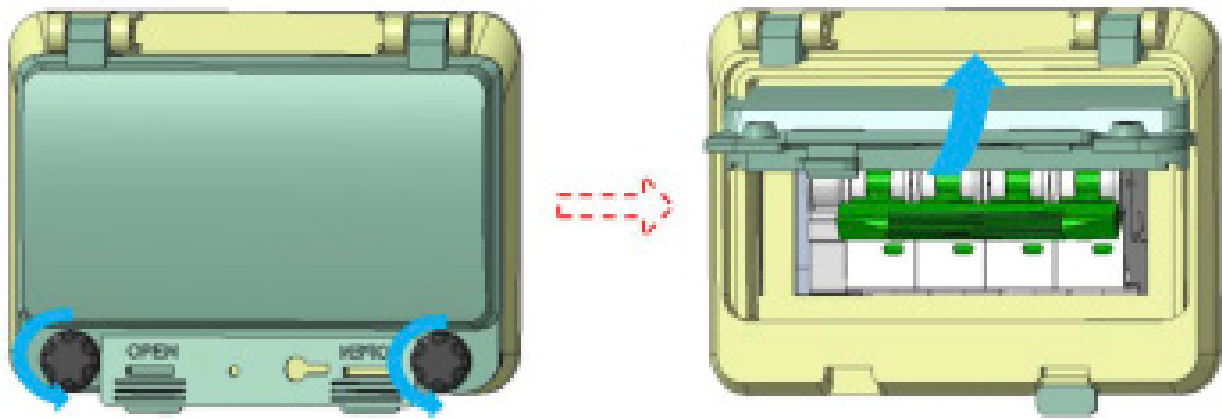

Graph 4.2-1

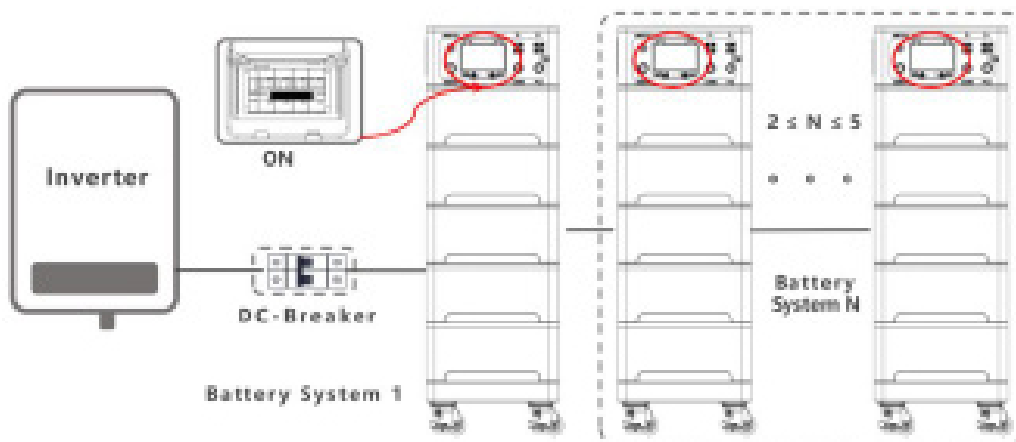

Graph 4.2-2

4.3 Shutdown steps



Danger:

When shutting down the battery system, please strictly follow the requirements for discharging the battery system to prevent damage to the battery system.

Step 1: Please perform the shutdown operation according to the user manual of the inverter to turn off the inverter in the system;

Step 2: In the cluster system, press the start button "SWITCH" on the battery system one by one to ensure that the display light of each "SWITCH" is off.

Step 3: If it is a cluster system, the circuit breakers between the battery systems should be disconnected in sequence;

Step 4: disconnect the circuit breaker between the inverter and the battery;

4.4 Mobile APP



Note: After the battery system is powered on, you can view the specific information of the battery on the "UDAN HESS" on the mobile phone.

Step 1: Download the "UDAN HESS" APP;

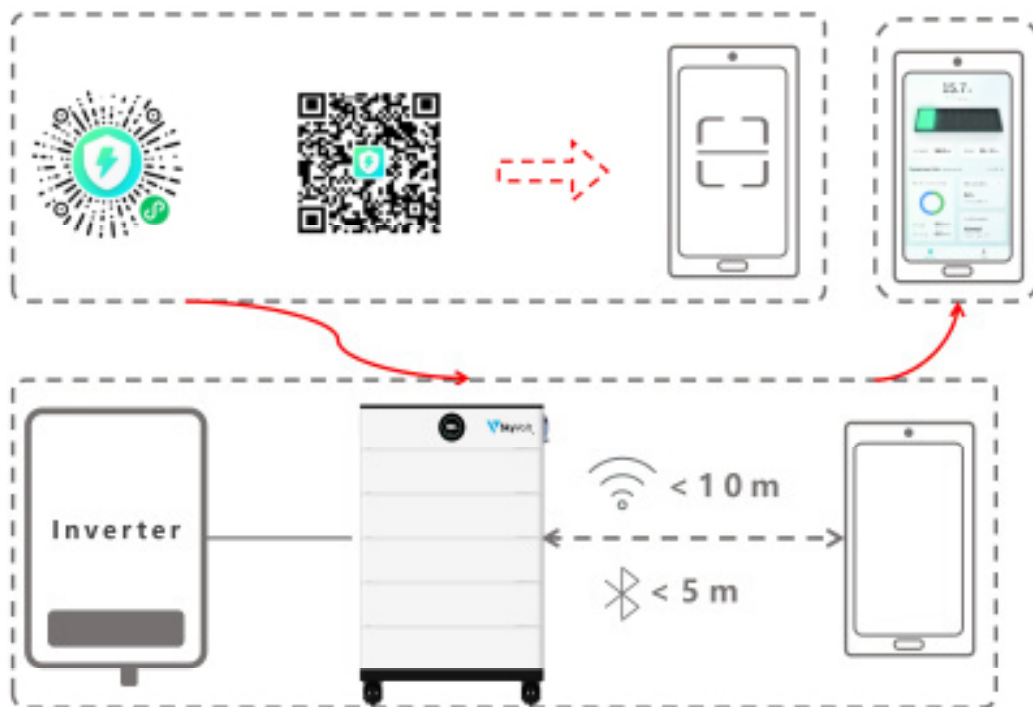

Graph 4.4-1

Step 2: Log in / register account

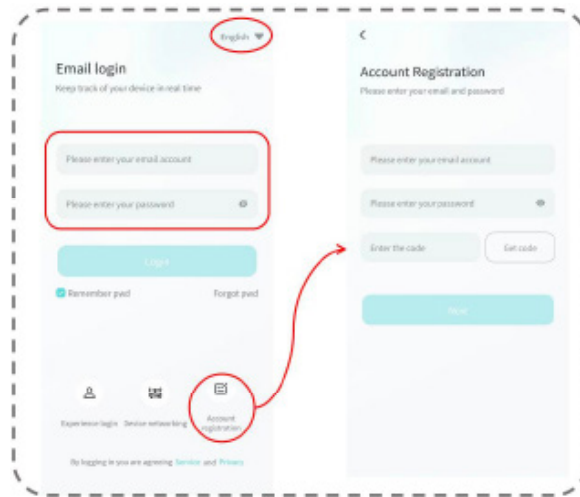

Graph 4.4-2

Step 3: Add device / device networking;



Graph 4.4-3



Note: The GPRS dedicated waterproof antenna for lithium battery pack is suitable for wireless data transmission;



Note: It is strictly prohibited to dismantle the antenna privately to cause irreversible damage; and the antenna should not be shielded by metal materials around it. At least one direction should not be blocked, otherwise it will affect the signal strength.

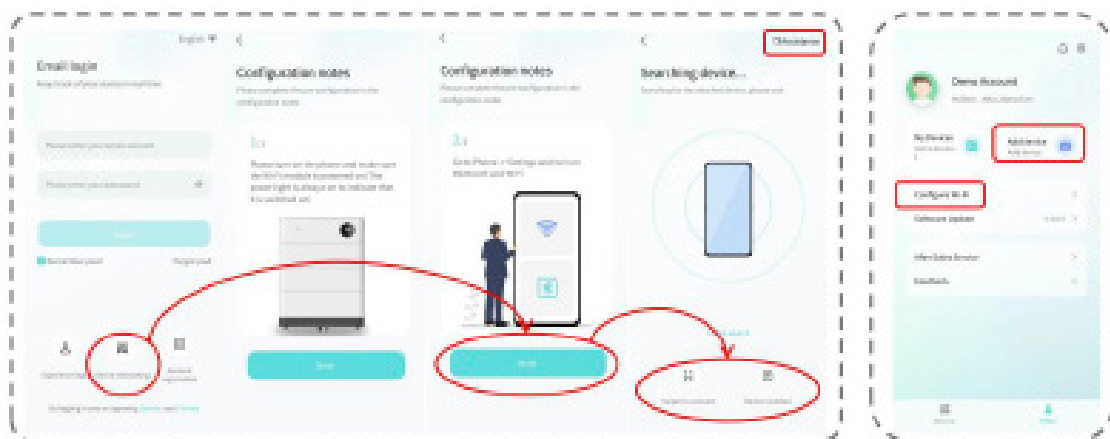

Graph 4.4-4



Note: Correctly configure the battery by scanning the device serial number;



Note: This device does not support the 5G band, so make sure you are connected to a WiFi network on the 2.4G band.

Step 4: battery status query;

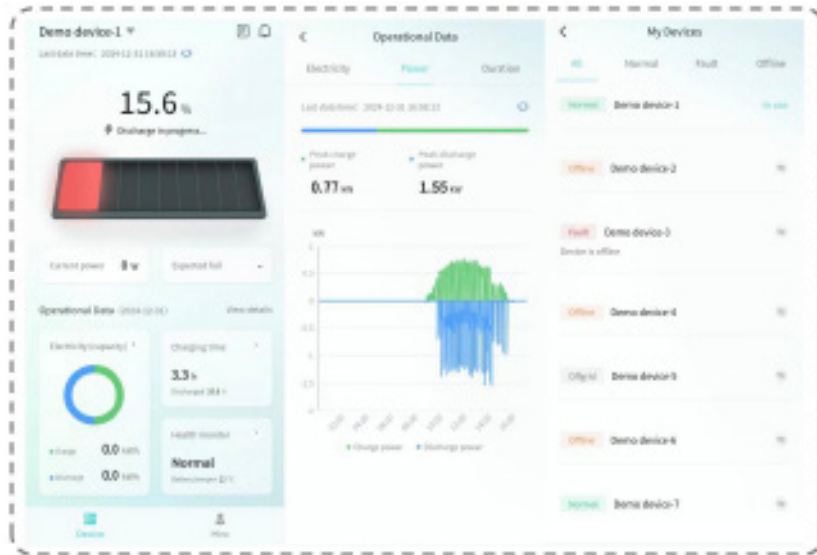

Graph 4.4-5

4.5 PC cloud platform

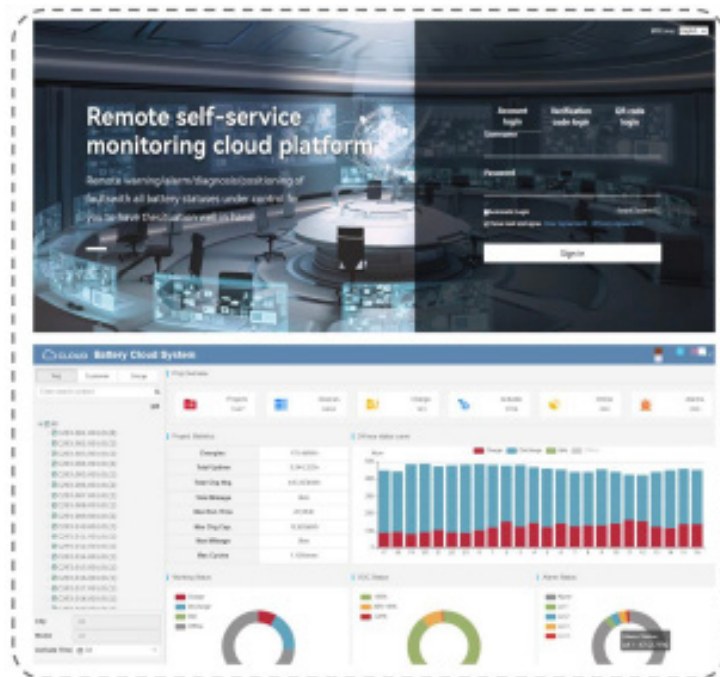

Graph 4.5

4.6 Battery display screen



Graph 4.6



Note: Battery management system (BMS) information can be read directly and displayed on the display.

4.7 Battery fault handling

When the battery system malfunctions, it may cause the system to shut down automatically or some of its functions to be abnormal; please carry out troubleshooting according to the following methods, and if these troubleshooting fails to solve the problem, please contact the after-sales service center in time. When contacting the after-sales service center, please prepare the following information in order to solve the problem quickly:

1. Battery information, such as: serial number, software version, equipment installation time, failure time, failure frequency, etc.;
2. Equipment installation environment, such as: weather conditions, etc., installation environment recommendations can provide photos, videos and other documents to assist in analyzing the problem;
3. Equipment use history, such as: equipment use frequency and duration, charging times, maintenance, etc., while specifying the type of after-sales service, such as on-site maintenance, return to the factory maintenance or use of guidance.

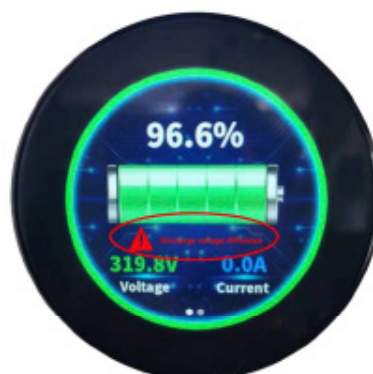

Graph 4.7

Fault name	Resolvent
The charging cell voltage is high The discharge cell voltage is high	Restart discharge immediately after the battery is left idle for 0.5h. If the problem still exists, please contact the after-sales service center
The charging cell voltage is low The discharge cell voltage is low	Restart charging immediately after the battery is left idle for 0.5h. If the problem still exists, please contact the after-sales service center
The total charging pressure is high The total discharge pressure is high	Restart discharge immediately after the battery is left idle for 0.5h. If the problem still exists, please contact the after-sales service center
The total charging pressure is low The total discharge pressure is low	Restart charging immediately after the battery is left idle for 0.5h. If the problem still exists, please contact the after-sales service center
Charging cell pressure difference Discharge cell pressure difference	If the problem still exists after restarting the battery, please contact the after-sales service center
Total charging pressure difference Discharge total pressure difference	If the problem still exists after re-starting the battery, please contact the after-sales service center
High charging temperature High discharge temperature	<ol style="list-style-type: none"> 1. Check the installation environment temperature to ensure that the installation temperature of the battery system meets the working temperature range of the battery; 2. Turn off the battery and turn on it after the temperature is restored.
Charging at low temperature Low discharge temperature	<ol style="list-style-type: none"> 1. Check the installation environment temperature to ensure that the installation temperature of the battery system meets the working temperature range of the battery; 2. Turn off the battery and turn on the machine after the temperature is restored.
Charging temperature difference Discharge temperature difference	<ol style="list-style-type: none"> 1. Check the installation environment temperature to ensure that the installation temperature of the battery system meets the working temperature range of the battery, and compare the temperature on the display screen; 2. Turn off the battery, and turn on it after the temperature is restored. If the problem still exists, please contact the after-sales service center.
Slow charge over current Continuous discharge over current	If it does not recover after 5 minutes, it needs to be restarted. If the problem still exists, please contact the after-sales service center
SOC is too low	Restart the battery and charge it. If the problem still exists, please contact the after-sales service center

Insulation leakage	Check whether the cable connection is normal, such as power line, grounding line, etc. If the problem still exists, please contact the after-sales service center
Voltage line leakage Warm discharge line leakage	Please contact the after-sales service center
Intranet communication failure	Please contact the after-sales service center
Pre-charging failed	Please contact the after-sales service center
Abnormal current	Please contact the after-sales service center
BMS initialization failure	If the problem still exists after restarting the battery, please contact the after-sales service center
Relay fault	Please contact the after-sales service center



Warning: If any fault other than Table 4.7 occurs, please contact the after-sales service center directly.

4.8 Patrol and maintenance



Warn:

If you find any problems that may affect the battery system, please contact after-sales immediately and do not disassemble it by yourself;

If the copper wire of the guide wire is exposed, do not touch it to prevent high voltage danger. Contact after-sales immediately and do not disassemble it by yourself;

In case of other emergencies, please contact the after-sales service immediately, follow its guidance or wait for the after-sales service personnel to handle the site.

Maintenance content	Maintenance cycle
Check if the battery system installation is loose, if so, tighten the corresponding position	Every six months
Check whether the shell is damaged, if so, please paint it or contact the after-sales service center	Every six months
Check whether the exposed wire is worn, if so, replace the corresponding cable	Every six months
Check whether there is no debris around the battery to avoid affecting the heat dissipation of the battery	Every six months
Check for water or pests to avoid long-term battery invasion	Every six months

4.9 Upper computer monitoring



Note:

1. Ensure that the upper computer software is compatible with the battery system and updated to the latest version;
2. Connect the "DEBUG" port in the battery system to avoid connecting the wrong port.



Graph 4.9-1

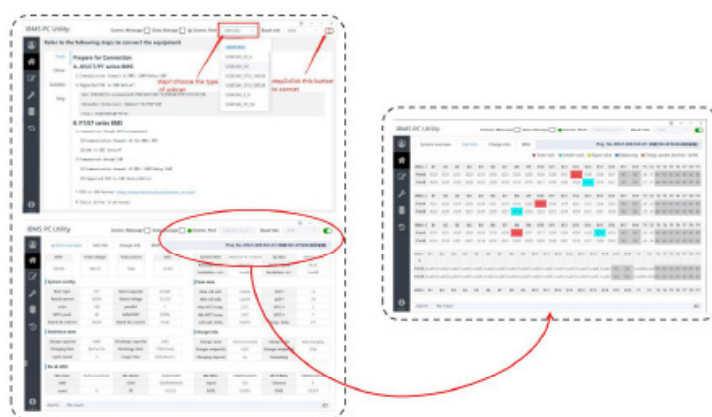

Graph 4.9-2



Explain:

After connecting the host to the battery system, users can monitor and extract a series of status data covering the battery such as SOC (State of Charge) and SOH(State of Health); this includes the total voltage of the battery system, individual cell voltages, total current, and current data during charging and discharging. At the same time, users can also obtain the temperature of individual cells and the overall battery temperature, as well as the usage history of the battery, such as the number of charge-discharge cycles and cumulative charging and discharging amounts. Safety information of the battery, including fault codes and insulation status, is also query able. In addition, users can access detailed information about system configuration and perform upgrade and debugging operations on the device.

Warranty Service

5.1 Warranty period

In the case of proper use of the product, the warranty period agreed in the business contract shall prevail.

5.2 Warranty scope

During the warranty period, if any malfunction is caused by quality issues with the product itself, our company will provide free repair or replacement services for the customer. The customer should allow our company a reasonable response time for repairs, and the replacement product will be handled by our company. The customer must present relevant proof of purchase for the product and ensure that the products trademark is clearly visible; otherwise, our company reserves the right to not provide warranty services.





5.3 Exemption Statement

In the event of any of the following circumstances, the Company shall have the right not to provide quality assurance, but shall still provide paid repair services.

1. The warranty period has expired;
2. Unable to provide relevant proof of product purchase;
3. Damage caused in the process of transportation and loading and unloading;
4. Damage caused by incorrect installation, modification or disassembly and repair by unauthorized personnel;
5. Damage caused by abnormal use conditions or environment;
6. Machine failure or damage caused by the use of non-natong components or software;
7. Fault caused by irresistible factors such as fire, earthquake and flood.

Appendix

6.1 Appendix A-Symbol Description

	Flammability risk
	Keep the battery away from open flame or ignition sources
	Recycling
	Danger of high voltages. Danger to life due to high voltages in the Energy storage system
	Danger. Risk of electric shock!
	CE certification
	Please read enclosed documentation carefully before using the product.
	This marking indicates that this product should not be disposed with other household wastes throughout the EU. To prevent possible harm to the environment or human health from uncontrolled waste disposal, recycle it responsibly to promote the sustainable reuse of material resources. To return your used device, please use the return and collection systems or contact the retailer where the product was purchased. They can take this product for environmental safe recycling.

6.2 Appendix B-System Connection Diagram

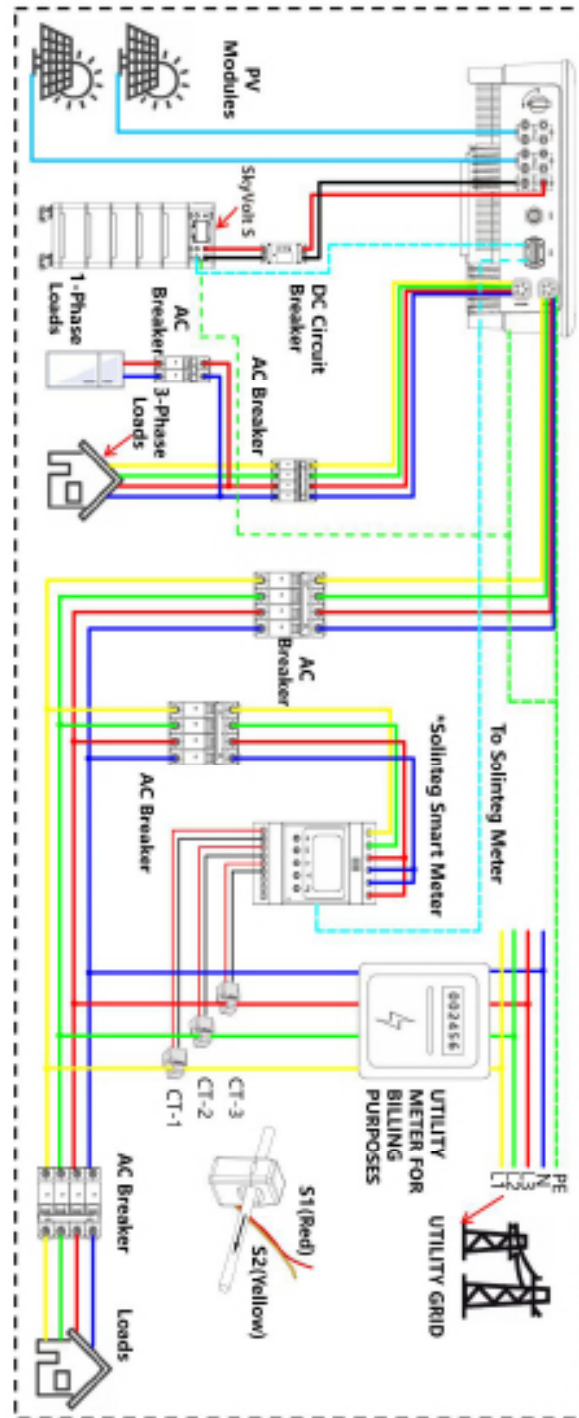

👉 Explain:

The figure shows the electrical system connection between the Solinteg storage MHT-4~20K series and the SkyVolt S battery; for details and operation instructions of the inverter, please refer to the Solinteg Storage user manual.

6.3 Appendix C-System Connection Diagram

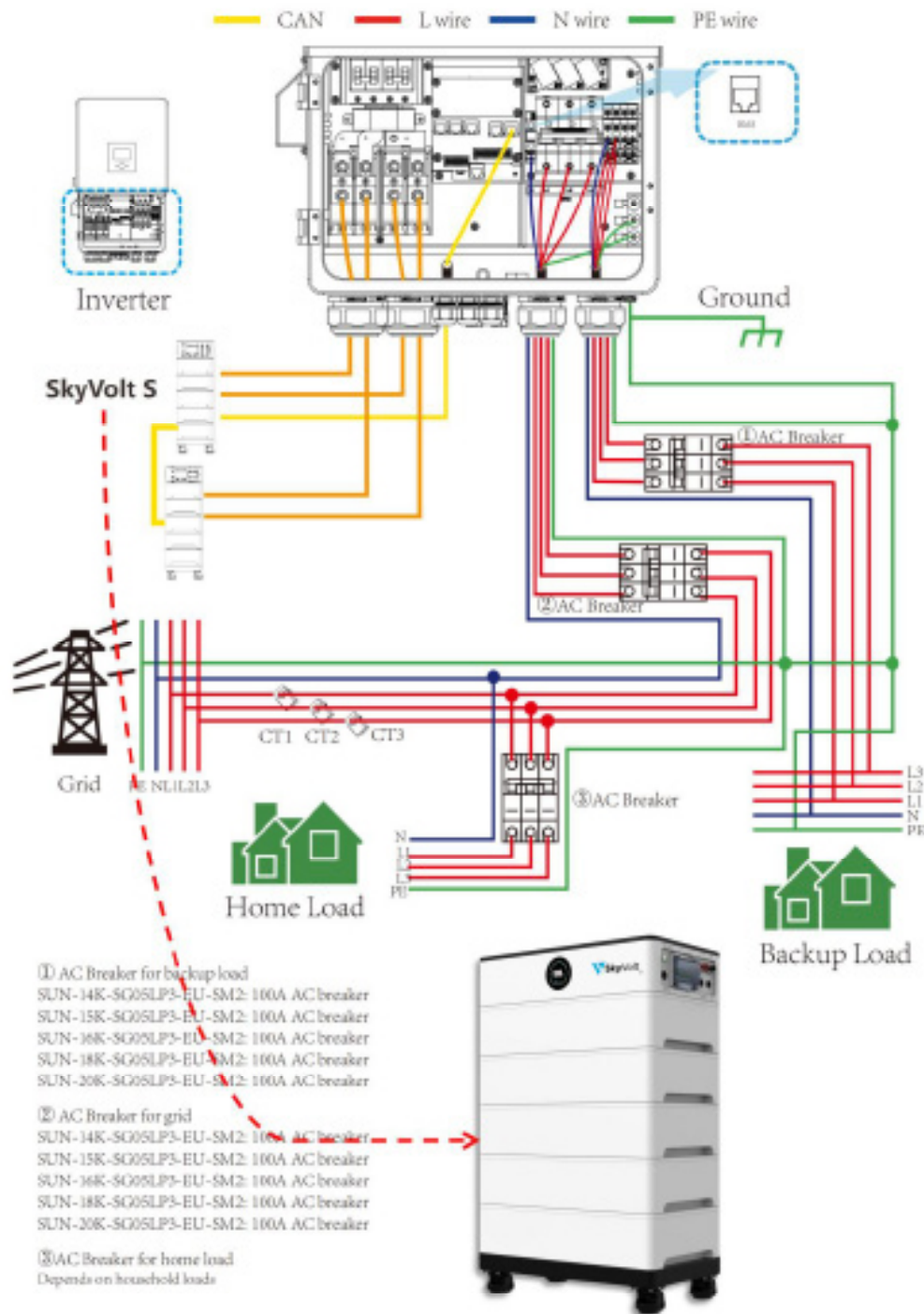

👉 Explain:

The figure shows the electrical system connection between the Deye SUN-14-20K-SG05LP3-EU-SM2 series and the SkyVolt S battery; for details and operating instructions of the inverter, please refer to the Deye user manual.



SKYENERGY.COM.AU