

User Manual

SkyVolt HV **Series**

Notice:

The products and services you purchase are subject to the commercial contracts and terms of **Sky Energy Investments Ptd Ltd 'Sky Energy'** All or part of the products and services described in this document may not be within the scope of your purchase or use. Unless otherwise agreed in the contract, **Sky Energy** does not make any express or implied statements or warranties regarding the contents of this document.

Due to product version upgrades or other reasons, the content of this document will be updated from time to time. Unless otherwise agreed, this document is only used as a guide, and all statements, information and suggestions in this document do not constitute any express or implied warranty.

Table of Contents

01 Safety Instructions	1
1.1 Safety Symbols	1
1.2 General Security	1
1.3 Personal Safety	4
1.4 Battery Leakage Treatment Measures	5
1.5 Electrical Safety	7
1.5.1 General Requirements	7
1.5.2 Wiring Requirements	7
1.5.3 Grounding Requirements	8
1.5.4 Maintenance Requirements	8
1.6 Mechanical Safety	9
1.7 Maintenance and Replacement	9
02 Product Introduction	10
2.1 Product Overview	11
2.2 Model Description	11
2.3 Product Appearance	13
2.4 Product Parameters	14
2.5 Product Details	16
2.6 Product Application	18
03 Product Installation	19
3.1 Storage Before Installation	19
3.2 Pre-installation Inspection	20
3.3 Installation Environment	20
3.4 Prepare Tools	23
3.5 Mechanical Installation	24
3.5.1 Battery system installation:	25
3.6 Electrical Connections	28
3.6.1 Single Battery System	29
3.6.2 Cluster Battery System	30
3.6.3 Power Line Connection	32
3.6.4 Communication Line Connection	37
3.6.5 Protective Ground Connection	39
3.6.6 External Connection Lines	39
3.6.7 Electrical System Connection	40
04 Operation & Maintenance	40
4.1 Check Before Power On	40

4.2 Boot Steps	41
4.3 Shutdown Steps	42
4.4 Mobile APP	45
4.5 PC-side Cloud Platform	47
4.6 Battery Display	48
4.7 Battery Failure Handling	49
4.8 Inspection and Maintenance	51
4.9 Host Computer Monitoring	52
05 Warranty Service	54
5.1 Warranty Period	54
5.2 Warranty Scope	54
5.3 Disclaimer	54
Appendix	55
Appendix A-Marking Description	55
Appendix B - System Connection Diagram	56
Appendix C - System Connection Diagram	57
Appendix D - System Connection Diagram	59

01 Safety Instructions

1.1 Safety Symbols

When installing, operating and maintaining the equipment, please read this manual first and follow all safety precautions marked on the equipment and in the manual. **To ensure that users can better use this product and protect personal and property safety, please read the following symbols carefully.**

 **DANGER:** Indicates a potentially hazardous situation which, if not avoided, will result in death or serious injury.

 **WARNING:** Indicates a situation with a moderately hazardous situation which, if not avoided, could result in death or serious injury.

 **CAUTION:** Indicates a situation with a low risk of hazard which, if not avoided, may result in moderate or minor injury.

 **NOTE:** Emphasis and supplementation of content may also provide tips for optimal use of the product.

1.2 General Security

 **Illustrate:**

This equipment should be used in an environment that meets the design specifications. Otherwise, it may cause equipment failure. The resulting equipment malfunction or component damage, personal safety accidents, property losses, etc. are not within the scope of equipment quality assurance. Local laws, regulations and specifications should be followed when installing, operating and maintaining the equipment. The safety precautions in the manual are only used as a supplement to local laws, regulations and specifications. The company does not assume responsibility for any of the following situations.

1. The installation and use environment exceeds the requirements of relevant international, national and regional standards.
2. Operation not within the conditions of use described in this manual.
3. Unauthorized disassembly, modification of products or modification of software codes.
4. Failure to follow the operating instructions and safety warnings in the product and documentation.
5. Equipment damage caused by abnormal natural environment (force majeure, such as earthquake, fire, storm, flood, mudslide, etc.).
6. Damage caused by the customer's failure to comply with transportation and installation requirements.
7. Damage caused by storage conditions not meeting the requirements of product documentation.
8. Damage to the hardware or data of the device due to customer negligence, improper operation or intentional damage .
9. System damage caused by a third party or customer , including relocation and installation of the system that does not comply with the requirements of this manual, and damage caused by adjustments, changes or removal of identification marks that do not comply with the requirements of this manual.
10. Defects, failures or damages caused by acts, events, omissions or accidents beyond the reasonable control of the Seller, including power outages or electrical failures, theft, war, riots, civil unrest, terrorism, intentional or malicious damage, etc.



Danger:

The equipment has high voltage. Improper operation may cause electric shock or fire, resulting in death, serious personal injury or serious property loss. Please follow the operation sequence and safety precautions given in this

manual and other related documents and operate in accordance with the regulations:

1. Please check whether the pre-installed cables are connected and tightened. Check whether the device is damaged, such as holes, dents, or other signs of possible internal damage. Check that the internal components of the device are not displaced. It is forbidden to change the structure and installation sequence of the device without authorization.

2. It is forbidden to use water to clean the electrical parts inside the equipment. If liquid is found to have entered the equipment, please press the emergency stop switch immediately and notify the on-site management personnel.

3. It is forbidden to install, connect, maintain and replace with power on. Before touching any conductor surface or terminal, measure the voltage at the contact point and confirm that the protective ground wire of the equipment or the part to be repaired is reliably grounded and there is no risk of electric shock.

4. Except for the personnel who operate the equipment, other personnel are not allowed to approach the equipment. Do not power on the equipment before the equipment is installed or confirmed by professionals. When powering on for the first time or operating the main circuit with power on, at least two personnel must be present on site.

 **Illustrate**

1. The user's operating behaviors and operating tools during transportation, handling, installation, wiring and maintenance must comply with the laws, regulations and relevant standards of the country and region where the user is located.

2. It is prohibited to reverse engineer, decompile, disassemble, adapt, implant or perform other derivative operations on the device software. It is not allowed to study the internal implementation of the device, obtain the source code of the device software, steal intellectual property rights, etc. in any way, and it is not allowed to disclose the results of any device software

performance test.

1.3 Personal Safety



Danger:

1. During the operation of the equipment, appropriate personal protective equipment should be worn. If a fault that may cause personal injury or equipment damage is found, the operation should be stopped immediately, reported to the person in charge, and effective protective measures should be taken.

2. Before using the tool, please master the correct use of the tool to avoid injury to people and damage to equipment.

3. When the device is running, some internal shell temperatures are high and there is a risk of burns, so do not touch them.

4. To ensure personal safety and normal use, reliable grounding should be carried out before use.

5. When the battery module fails, the temperature may exceed the burn threshold of the touchable surface and contact should be avoided.

6. Do not open or damage the battery module. The released electrolyte is harmful to the skin and eyes and should be avoided.

7. Do not place irrelevant objects on top of the device or insert them into any part of the device.

8. Do not place flammable items around the device.

9. Batteries are strictly prohibited from being placed in fire to avoid explosion and endangerment to personal safety.

10. Do not place the battery module in water or other liquids.

11. Never short-circuit the battery module terminals. Short-circuiting the battery may cause burns.

12. Batteries may cause danger of electric shock and large short-circuit current.

13. Do not use water or detergent to clean the electrical components inside and outside the device.

14. Do not stand, lean or sit on the equipment.

15. Do not damage the modules of the device.

16. When installing the battery module, if the battery module falls or is hit hard, it will cause damage to the equipment. It is strictly forbidden to continue using it, otherwise there will be safety risks (battery leakage, electric shock, etc.).



Warn:

1. Remove watches, rings or other metal objects.
2. Use tools with insulated handles.
3. Wear rubber gloves and boots.
4. Do not place small tools or metal parts on top of the battery module.
5. Disconnect the charging power source before connecting or disconnecting the battery terminals.
6. Determine if the battery is accidentally grounded. If it is accidentally grounded, remove the power supply from the ground. Contact with any part of the grounded battery may cause electric shock. If these grounds are removed during installation and maintenance, the possibility of this electric shock can be reduced.

1.4 Battery Leakage Treatment Measures



Notice:

When electrolyte leakage occurs, the following emergency measures can be taken depending on the severity of the leakage.

1. Ensure adequate ventilation and eliminate all ignition sources.

2. Quickly evacuate personnel to a safe area, away from the leakage area and in the upwind direction.

3. Use personal protective equipment and avoid inhaling steam, smoke, gas or dust.

4. Take measures to prevent further leakage or overflow while ensuring safety.

5. In case of a small leakage, dry sand or inert adsorbent materials can be used to absorb the leak. In case of a large leakage, a dam must be built to control it.

6. Attachments or collections should be stored in suitable sealed containers and disposed of in accordance with local laws and regulations.

7. Eliminate all ignition sources and use spark-proof tools and anti-riot equipment.



Danger:

In the event of a leak, avoid contact with leaking liquid or gas. The electrolyte is corrosive and contact may cause skin irritation and chemical burns. If you come into contact with battery electrolyte, you need to take the following measures.

1. Inhalation: Evacuate the contaminated area and move to fresh air immediately to keep breathing unobstructed; if breathing is difficult, give oxygen; if the patient ingests or inhales this substance, do not perform mouth-to-mouth artificial respiration; if breathing stops, immediately perform cardiopulmonary resuscitation; and seek medical help immediately.

2. Eye contact: Immediately rinse eyes with plenty of water for at least 15 minutes, do not rub, and seek medical help immediately.

3. Skin contact: Take off contaminated clothing immediately, wash the skin contact area with plenty of water and soap, and seek medical help immediately.

4. Ingestion: Do not induce vomiting. Never feed anything by mouth to an unconscious person. Seek medical help immediately.

5. Protection of emergency personnel: Ensure that medical personnel understand the hazardous characteristics of the product and take personal protective measures to protect themselves and prevent the spread of contamination.

1.5 Electrical Safety

1.5.1 General Requirements



Illustrate:

1. All electrical connections must meet the electrical standards of the country/region.

2. You must obtain permission from the power department of the country/region before you can connect to the grid for power generation.

3. User-supplied cables must comply with local laws and regulations.

4. When performing high voltage operations, please use special insulating tools.



Danger: Before making electrical connections, make sure the device is not damaged, otherwise it may cause electric shock or fire.

1.5.2 Wiring Requirements

1. Please select cables that comply with local laws and regulations. Cables of the same type should be bundled together, and cables of different types should be laid separately. They should not be entangled or crossed.

2. The cables used in the high-voltage stacking machine must be firmly connected, well insulated, and meet the specifications. The cable conduit or wire hole must be protected to prevent the cables from being damaged by sharp edges, burrs, etc.

3. Using cables in high temperature environments may cause aging and damage of the insulation layer. The distance between the cables and the

heating device or the periphery of the heat source area should be at least 30mm.

4. To ensure construction safety, all cables should be laid and installed above 0°C. When moving cables, especially when working in low temperature environments, they should be handled with care.



Danger: It is forbidden to install or remove the power cord while it is powered on. When the power cord core contacts the conductor, an arc or spark will be generated, which may cause fire or personal injury.

1.5.3 Grounding Requirements

1. When installing equipment that needs to be grounded, the protective ground wire must be installed first; when dismantling the equipment, the protective ground wire must be removed last.

2. It is prohibited to damage the grounding conductor.

3. It is prohibited to operate the equipment without installing a grounding conductor.

4. The equipment should be permanently connected to the protective ground. Before operating the equipment, check the electrical connection of the equipment to ensure that the equipment is reliably grounded.

1.5.4 Maintenance Requirements

1. Before connecting or removing cables, the protection switch of the corresponding circuit must be turned off.

2. Use a multimeter of the corresponding voltage level to check whether it is energized and ensure that the equipment is completely powered off.

3. If there is a charged object nearby, please use an insulating board or insulating tape to cover or wrap it.

4. Use the grounding wire to reliably connect the circuit to be inspected to the grounding circuit before performing operation and maintenance.



Illustrate:

1. Before connecting cables, make sure the cable labels are correct.
2. If the device has multiple inputs, all inputs of the device should be disconnected and the device can be operated only after it is completely powered off.
3. After the inspection is completed, remove the grounding wire between the inspection circuit and the grounding circuit.

1.6 Mechanical Safety

1. When moving equipment by hand, you should be prepared to bear the weight and wear protective gloves, anti-smash shoes and other safety protection equipment.
2. Move the equipment carefully during transportation to avoid collision or drop. Avoid scratching the surface of the equipment and damaging parts or cables.
3. When transporting equipment, the large size of the equipment may block the operator's view, so auxiliary personnel need to be arranged to assist.

1.7 Maintenance and Replacement

Please maintain the equipment only after you are familiar with and understand the contents of this manual and have appropriate tools and test equipment.

1. Before performing maintenance work, please power off the device first, then follow the instructions on the delayed discharge label and wait for the corresponding time to ensure that the device is powered off before operating the device.
2. During the maintenance process, please try to avoid irrelevant personnel entering the maintenance site, and temporary warning signs or fences must be erected for isolation.
3. If the equipment fails, please contact your dealer in time.
4. The equipment can be powered on again only after the fault has been resolved. Otherwise, the fault may expand or the equipment may be damaged.

5. Unauthorized persons are not allowed to open the cover without authorization, otherwise there will be a risk of electric shock, and the resulting malfunction is not covered by the warranty.

6. Operators, maintenance personnel and professional technicians should receive adequate training on safe use and equipment maintenance, and should operate with adequate preventive measures and personal protective equipment.

7. When moving or rewiring is required, the power input must be cut off. After waiting for 5 minutes for the internal energy of the machine to be discharged, and after using a multimeter to confirm that there is no dangerous voltage on the DC bus and the parts to be repaired inside the machine, maintenance can be started.

8. Battery maintenance should be performed or supervised by personnel familiar with batteries and the necessary precautions.

9. When replacing batteries, please replace with battery modules of the same type.

10. After the maintenance operation is completed, check immediately to ensure that no tools or other parts are left in the equipment.

11. If the device is not used for a long time, the battery needs to be stored and recharged according to this manual.



Danger:

During the operation of the equipment, there is high voltage, which may cause electric shock, resulting in death, serious personal injury or serious property loss. Therefore, before performing any maintenance work, the equipment must be powered off and the safety precautions listed in this manual and other related documents must be strictly followed.

02 Product Introduction

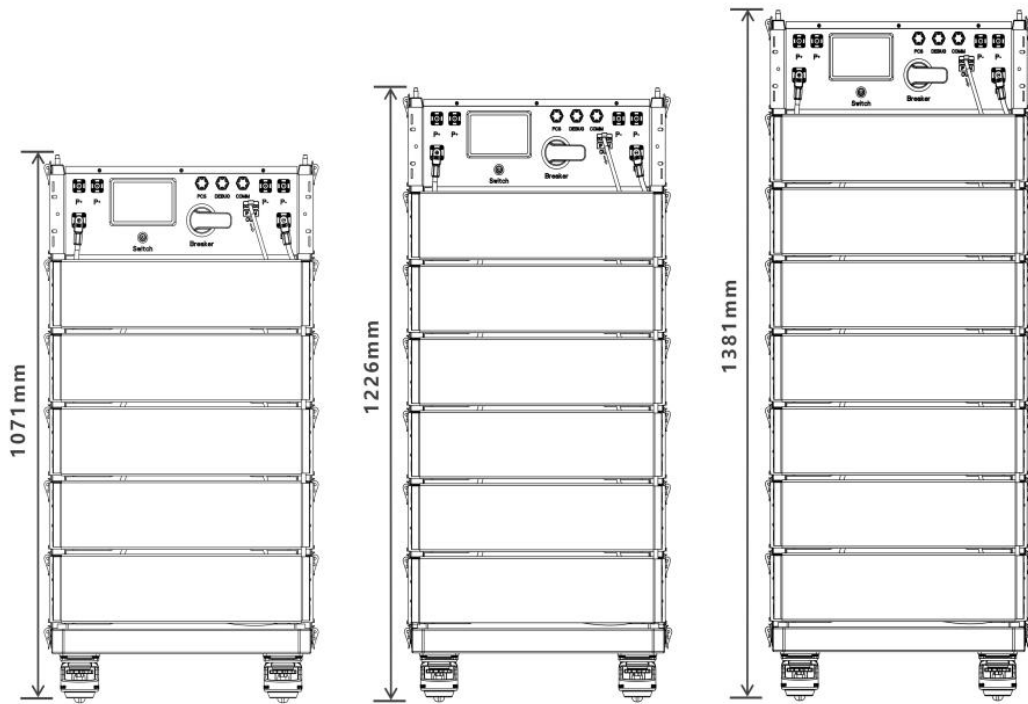

Figure 2. 2-2

HV PACK 8/9/10:

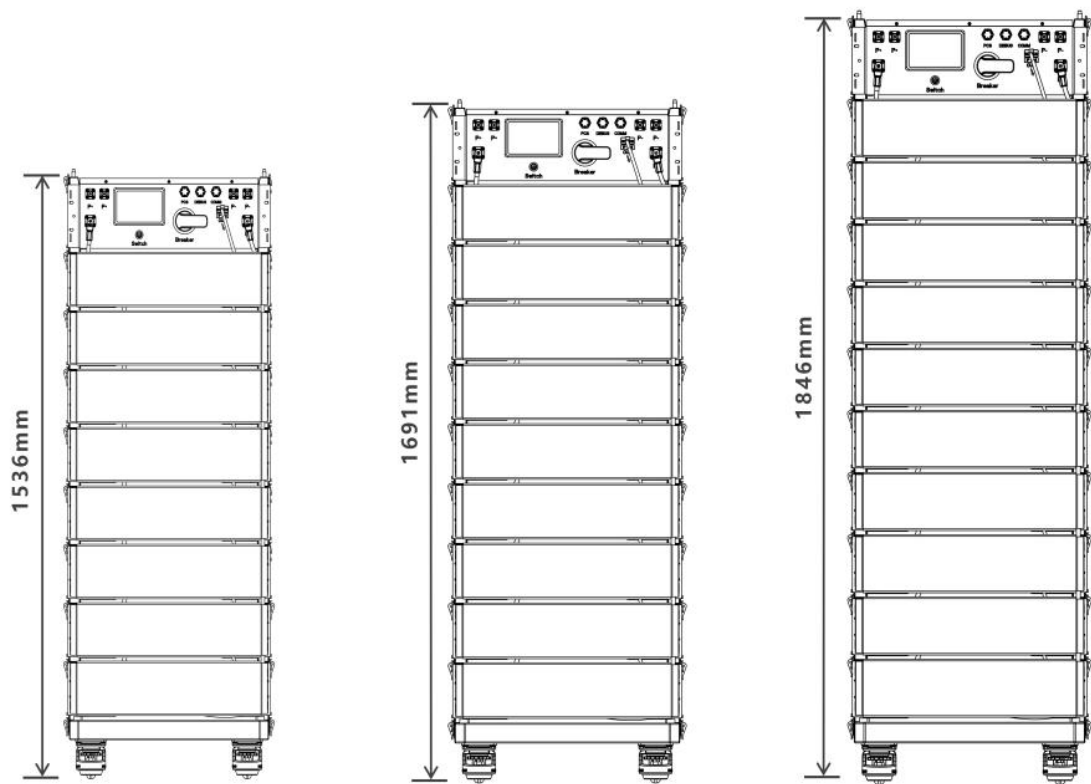

Figure 2. 2-3

HV PACK 11/12 (Connection method 1):

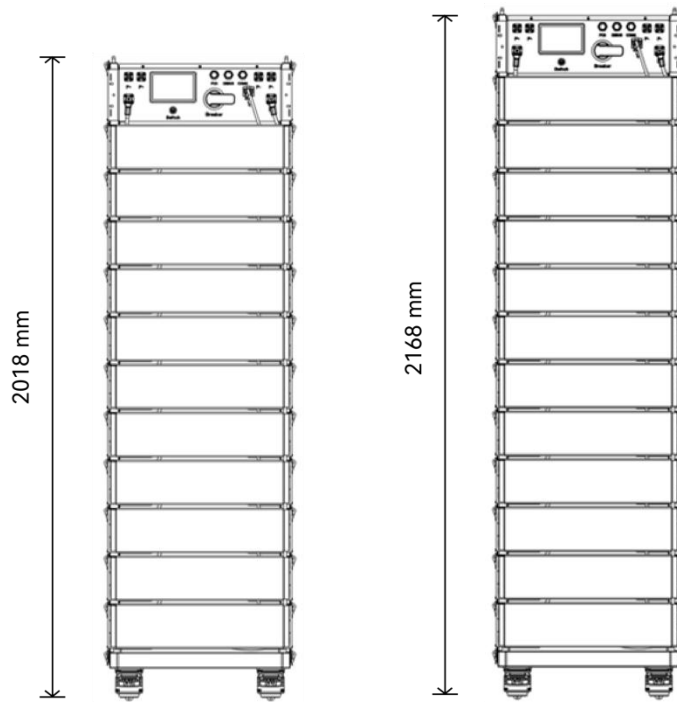

Figure 2. 2-4

HV PACK 11/12 (Connection method 2):

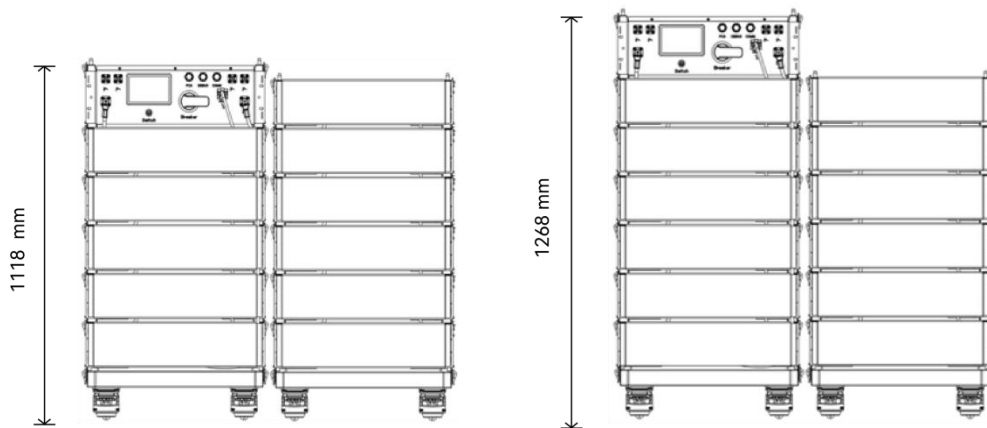

Figure 2. 2-5



Illustrate:

1. The actual height may vary slightly, please refer to the actual installation height ;
2. Series stacking can be freely matched according to project configuration .

2.3 Product Appearance

ESS-GRID HV PACK 7



Figure 2.3



Note: Different projects have different configurations, the actual configuration is subject to shipment.

2.4 Product Parameters

ESS-GRID HV PACK Technical Parameters

Model Number	HV-39-R	HV-46-R	HV-54-R
Rated Voltage	288.0V	345.6V	403.2V
Rated Capacity	135Ah	135Ah	135Ah
Cell Brand(LFP-3.2V)	REPT 135Ah	REPT 135Ah	REPT 135Ah
System configuration	90S1P	108S1P	126S1P
Battery single box number	5pack+1control box	6pack+1control box	7pack+1control box
Rated power	38.88kWh	46.66kWh	54.43kWh
Charge Upper Voltage	319.5V	383.4V	447.3V
Discharge Lower Voltage	256.5V	307.8V	359.1V
Recommended Current	68A	68A	68A
Maximum Charging Current	120A	120A	120A
Maximum Discharging Current	120A	120A	120A
Dimension (W*D*H, mm)	568*713*1071	568*713*1226	568*713*1381
Weight(kg)	366.83	432.37	497.91
Altitude	2000m	2000m	2000m
Communication protocol	CANBUS(Baud rate @500Kb/s or @250Kb/s)/Modbus RTU(@9600b/s)		

Host software protocol	CANBUS (Baud rate @250Kb/s)
Operation Temperature Range	Charge:0~55°C Discharge:-20~55°C
Cycle Life (25°C)	> 6000 @ 90%DOD
Protection level	IP20
Storage Temperature	-10°C~40°C
Storage Humidity	10%RH~90%RH
Internal Impedance	≤1Ω

Table 2. 4-1

Model Number	HV-62-R	HV-70-R	HV-78-R
Rated Voltage	460.8V	518.4V	576.0V
Rated Capacity	135AH	135AH	135AH
Cell Brand(LFP-3.2V)	REPT 135Ah	REPT 135Ah	REPT 135Ah
System configuration	144S1P	162S1P	180S1P
Battery single box number	8pack+1control box	9pack+1control box	10pack+1control box
Rated power	62.21 kWh	69.98kWh	77.76kWh
Charge Upper Voltage	511.2V	575.1V	639.0V
Discharge Lower Voltage	410.4V	461.7V	513.0V
Recommended Current	68A	68A	68A
Maximum Charging Current	120A	120A	120A
Maximum Discharging Current	120A	120A	120A
Dimension (W*D*H, mm)	568*713*1536	568*713*1691	568*713*1846
Weight(kg)	563.45	628.99	694.53
Altitude	2000m	2000m	2000m

Communication protocol CANBUS(Baud rate @500Kb/s or @250Kb/s)/Modbus RTU(@9600b/s)

Host software protocol	CANBUS (Baud rate @250Kb/s)
Operation Temperature Range	Charge:0~55°C Discharge:-20~55°C
Cycle Life (25°C)	> 6000 @ 90%DOD
Protection level	IP20
Storage Temperature	-10°C~40°C
Storage Humidity	10%RH~90%RH
Internal Impedance	≤1Ω

Table 2. 4-2

Model Number	HV-86-R	HV-93-R
Rated Voltage	633.6V	691.2V
Rated Capacity	135AH	135AH
Cell Brand(LFP-3.2V)	REPT 135Ah	REPT 135Ah

System configuration	198S1P	216S1P
Battery single box number	11pack+1control box	12pack+1control box
Rated power	85.5kWh	93.3kWh
Charge Upper Voltage	702.9V	766.8V
Discharge Lower Voltage	564.3V	615.6V
Recommended Current	68A	68A
Maximum Charging Current	120A	120A
Maximum Discharging Current	120A	120A
Dimension (W*D*H, mm)	568*713*2018	568*713*2168
Weight(kg)	760.07	826
Altitude	2000m	2000m
Communication protocol	CANBUS(Baud rate @500Kb/s or @250Kb/s)/Modbus RTU(@9600b/s)	
Host software protocol	CANBUS (Baud rate @250Kb/s)	
Operation Temperature Range	Charge:0~55°C Discharge:-20~55°C	
Cycle Life (25°C)	> 6000 @ 90%DOD	
Protection level	IP20	
Storage Temperature	-10°C~40°C	
Storage Humidity	10%RH~90%RH	
Internal Impedance	≤1Ω	

Table 2. 4-3



Illustrate:

It is not recommended to operate the battery at the maximum charge and discharge current for a long time. The rated capacity of the battery is 135Ah at 25°C. The charge and discharge current and power will change according to the temperature and battery SOC.

2.5 Product Details

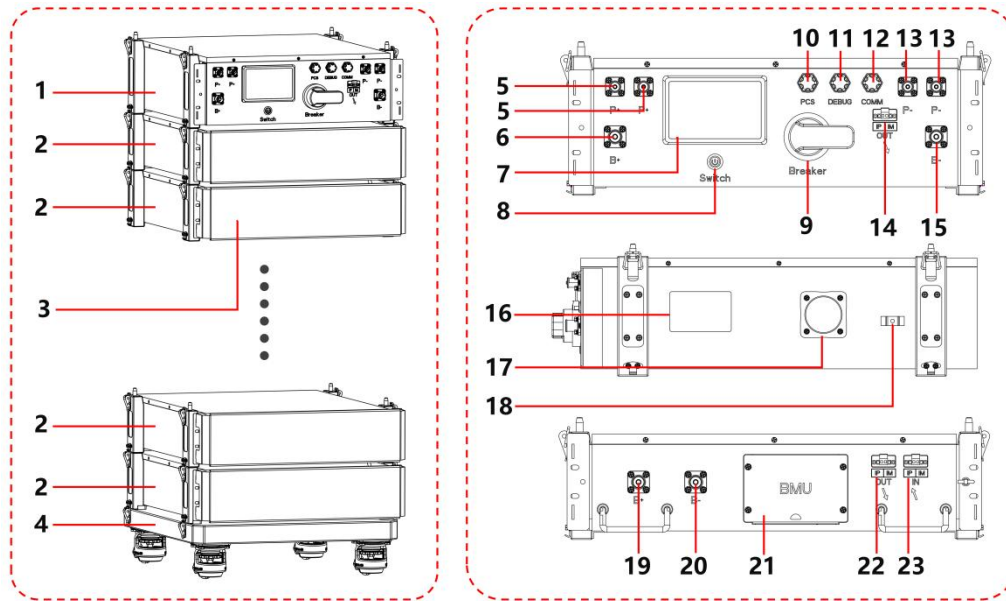

Figure 2.5

Battery Parts Instructions Sheet

Serial number	Part Name	Illustrate
1	Battery control box	Control battery system operation
2	Battery Module	57.6V 135Ah
3	Battery protection cover	/
4	Battery base	Base with wheels for easy battery position adjustment
5	Control box positive socket	Connect the external positive DC cable to the positive pole of the inverter
6	Control box positive terminal	Connect the positive terminal of the battery box
7	Display	Display battery status information
8	Power button	Control the low voltage circuit "on/off" in the battery system
9	DC circuit breaker	Control the on/off of the battery high voltage circuit
10	PCS Communication Port	Communication connection between battery and inverter
11	Debug Port	Used to communicate with the computer to monitor and upgrade the battery
12	Parallel Communications Port	Communication connection between HVS batteries
13	Control box negative socket	Connect external negative DC cable, which can be connected to the negative pole of the inverter
14	Control box internal communication port	Communication port between BMU and BCU in battery system
15	Control box negative terminal	Connect the negative terminal of the battery box
16	Battery nameplate	That is, the "battery ID card"

17	4G&Wifi Antenna	/
18	Protective ground terminal	Connect the battery system protective grounding cable
19	Battery box positive terminal interface	Connect the positive pole of the control box or the negative pole of the upper battery box
20	Battery box negative terminal interface	Connect the negative pole of the control box or the positive pole of the lower battery box
21	BMU	Battery Management System Slave Control
22	Battery box communication output port	Output of BMU in battery system
23	Battery box communication input port	Input of BMU in battery system

Table 2.5

2.6 Product Application

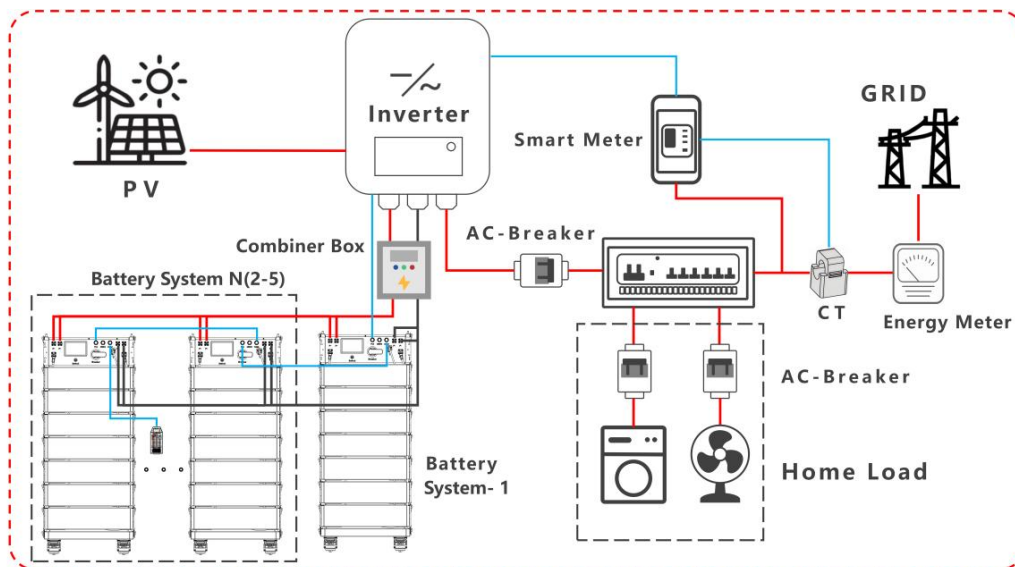

Figure 2. 6-1

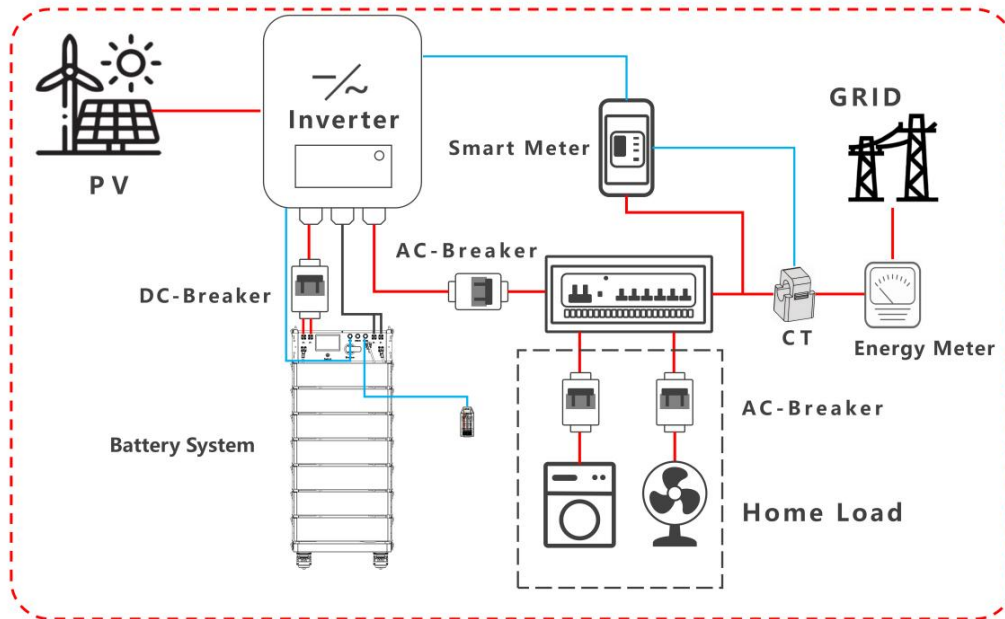

Figure 2. 6-2



Illustrate:

1. The battery cluster systems in Figures 2.6-1 and 2.6-2 are stacked in series;
2. The circuit breakers between the inverter and the battery, and between the battery system should be installed in accordance with local laws and regulations.

03 Product Installation

3.1 Storage Before Installation

1. **Preparation before storage:** Make sure the outer packaging box of the equipment is intact and do not dismantle it ; make sure the desiccant in the box is not lost to keep the inside dry.

2. **Storage environment requirements:** When storing the equipment, keep it away from flammable, explosive, corrosive and other items ; store the equipment in a cool place and avoid direct sunlight ; ensure that the storage environment is clean, the temperature and humidity range is appropriate, and there is no condensation.

3. **Battery storage requirements:** The SOC (state-of-charge) range of the stored battery should be 25%~50% SOC ; the battery needs to be charged and discharged once every 6 months of storage.

4. **Storage temperature range:** When the temperature is between -10 °C and 0°C, the storage time shall not exceed 1 month ; when the temperature is between 0°C and 35°C, the storage time shall not exceed 1 year ; when the temperature is between 35°C and 45°C, the storage time shall not exceed 1 month.

5. **Storage humidity range:** The storage humidity range is 10 ~ 90 % RH, no condensation ; if moisture condensation is found on the battery interface, the battery system cannot be installed and should be handled properly.

3.2 Pre-installation Inspection

1. **Outer packaging inspection:** Verify whether the outer packaging is intact, including whether there are deformations, holes, cracks or other signs that may cause damage to the internal equipment.

2. **Equipment model and delivery parts inspection:** Check whether the equipment model is consistent with the order ; confirm whether the type and quantity of the delivery parts are correct, and check whether there is any damage on the appearance.

3.3 Installation Environment

1. **Installation environment requirements:** The equipment must not be installed in a flammable, explosive, or corrosive environment ; the installation location should be out of reach of children and should be located in a location that is not easily touched accidentally ; at the same time , note that the surface of the equipment may generate high temperatures when it is running to prevent burns.

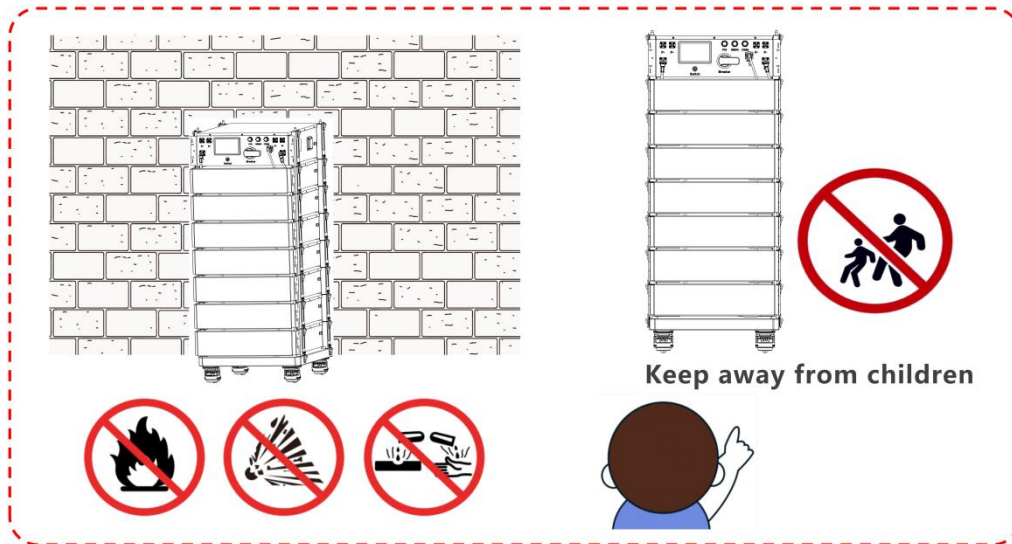

Figure 3.3-1

2. **Notes on the installation location:** Avoid installing near water pipes, cables, etc. inside the wall to prevent damage to the battery . The installation environment should avoid direct sunlight, rain, and snow. It is recommended to install it in a well-ventilated place indoors . If necessary, install an air-cooled air conditioner.

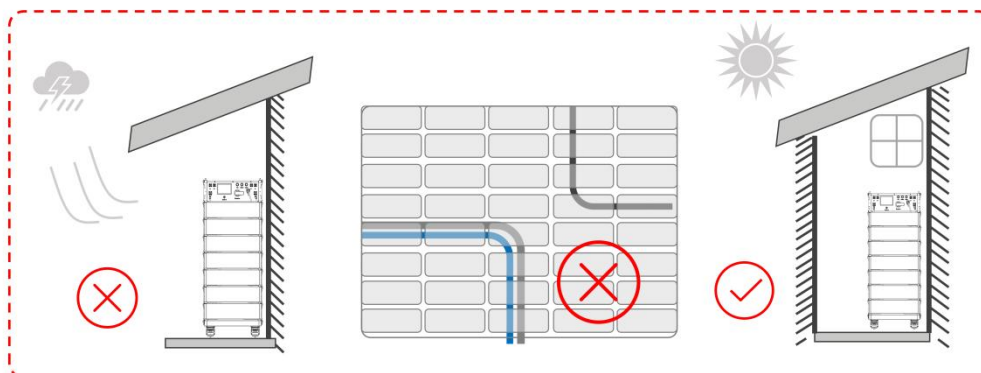

Figure 3.3-2

3. **Installation space and environmental conditions:** Ensure that the installation space meets the ventilation and heat dissipation and operating space requirements of the equipment ; the protection level of the equipment is suitable for indoor installation, and the temperature and humidity of the installation environment must be kept within an appropriate range.

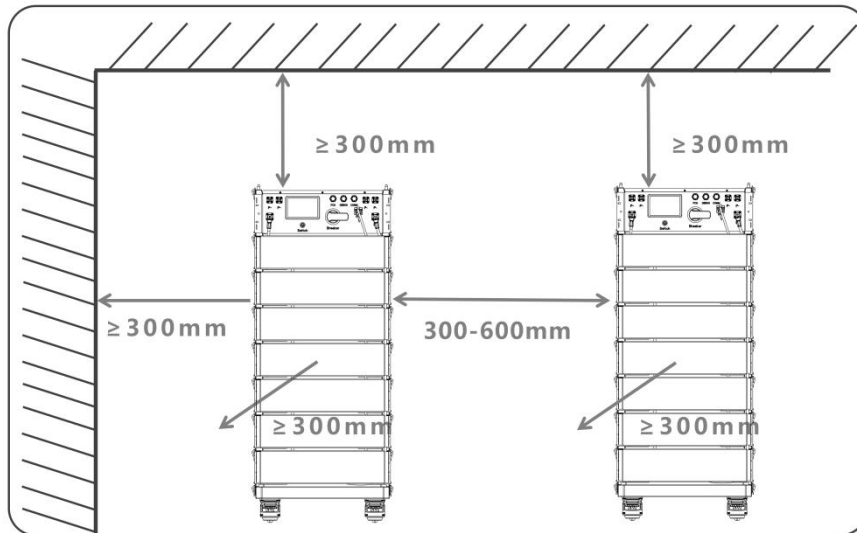

Figure 3.3-3

4. **Equipment installation height and protection:** The equipment installation height should be convenient for operation and maintenance, ensuring that indicator lights and labels are clearly visible and wiring terminals are easy to operate ; the equipment installation altitude should not exceed 2,000 meters.

5. **5. Electromagnetic interference protection:** The installation location should be away from strong magnetic fields to avoid interference; if the installation location near the radio station or 30MHz wireless communication equipment, the distance between the battery and these devices should be greater than 30 metres.

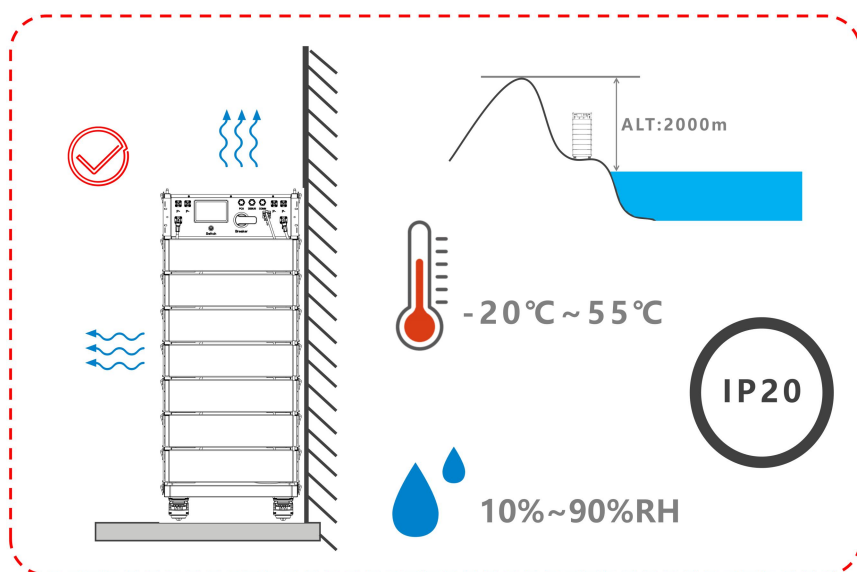

Figure 3.3-4

6. **Requirements for installation carrier:** Use non-flammable materials (such as concrete, masonry, or fire-resistant wood or metal) ;

The carrier must be sturdy and able to bear the weight of the equipment ; the battery system must be installed against the wall and equipped with an anti-dump bracket.

7. **Installation angle requirements:** The device must be installed horizontally to avoid tilting or inverting.

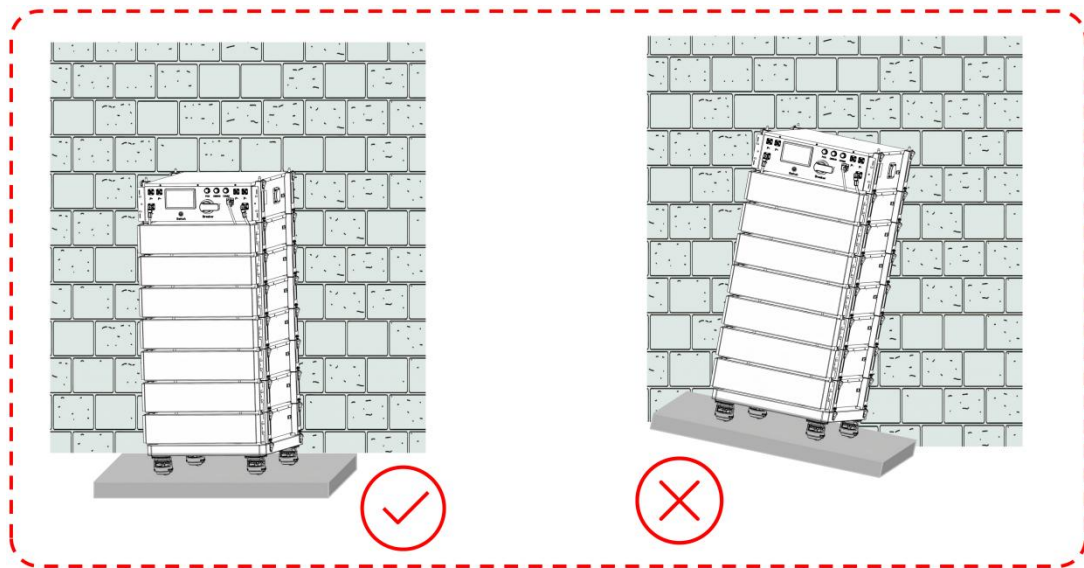





Figure 3.3-5

3.4 Prepare Tools

Installation Tool Table

Serial number	Tool Name	legend
1	Insulating gloves	
2	Protective glasses	
3	Insulated shoes	
4	Work clothes	









5	helmet	
6	screwdriver	
7	Wire strippers	
8	Hydraulic pliers	
9	Heat Gun	
10	multimeter	
11	Torque wrench	
12	Marking pen	

Table 3.4

 **Note:** This table is for reference only. The actual tools should be based on local installation standards.

3.5 Mechanical Installation

 **Notice:**

1. During transportation, handling and installation, local laws, regulations and industry standards must be observed;
2. Arrange the transporters appropriately according to the weight of the battery to prevent injuries caused by overweight handling; at the same time, be sure to wear safety gloves to protect your hands;
3. Please ensure that the battery remains balanced during transportation to avoid falling.

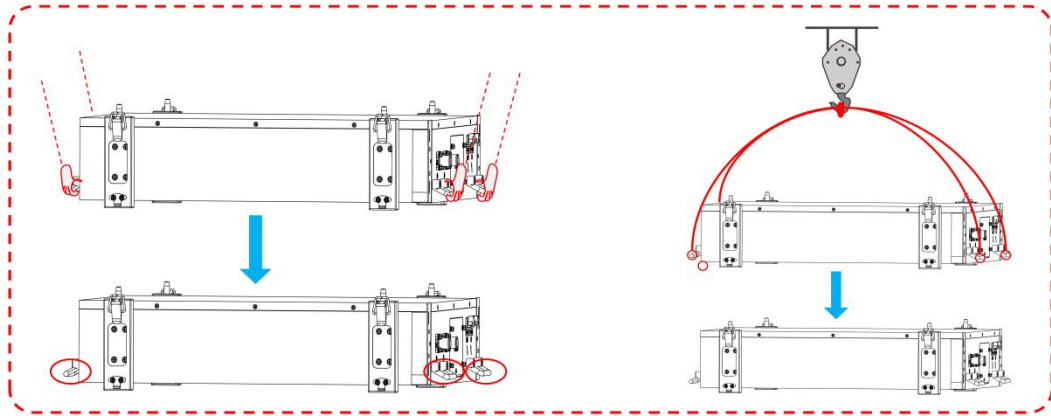



Figure 3.5-1

 **Note:** During the installation process, ensure that there are at least two people operating to ensure safety.

3.51 Battery system installation:

Step 1:

Adjust the four pulleys under the supporting battery base and ensure that the battery base is firmly fixed on the carrier of non-flammable material by operating the gears;

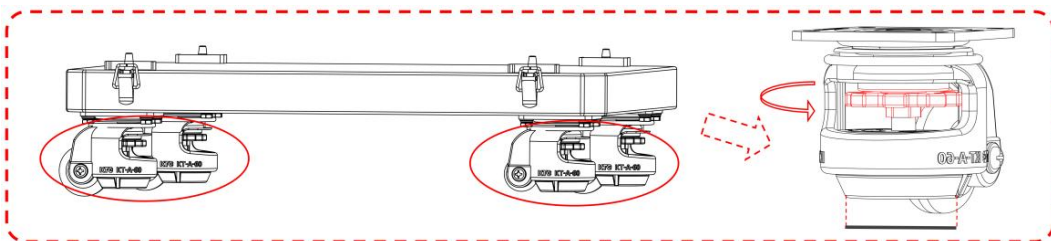



Figure 3.5-2

Step 2:

Place the bottom battery PACK on the base, and fix the battery in the limit column in the base through the mounting brackets around it to ensure a stable installation;

 **Note:** The battery base has "only tower buckles with limit posts around it".

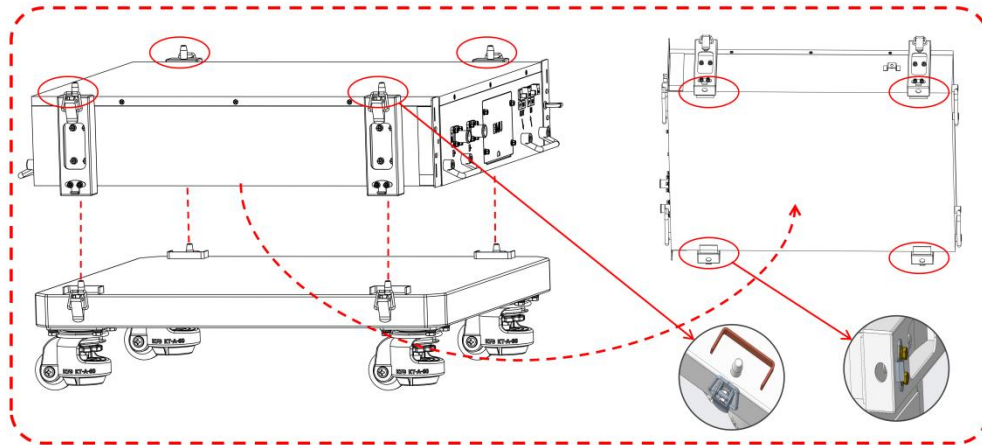

Figure 3.5-3

Step 3:

When installing the battery pack, first align the limiting holes of the upper battery with the limiting posts of the lower battery, and then fasten the tower buckles of the surrounding brackets to ensure that the two layers of batteries are firmly connected;

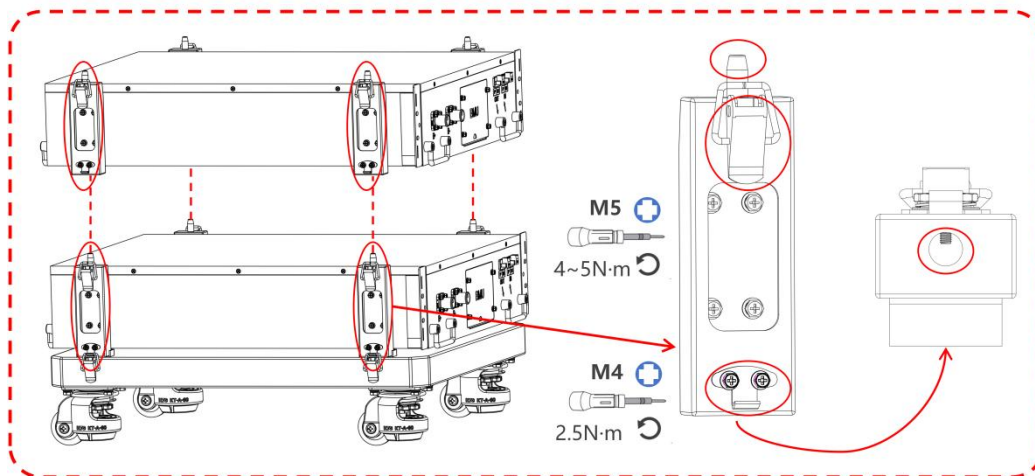

Figure 3.5-4



Notice:

During battery installation, always wear insulating gloves to prevent electric shock.

Step 4:

Repeat "Step 3" according to the battery model on the delivery list until the required number of battery packs are stacked;

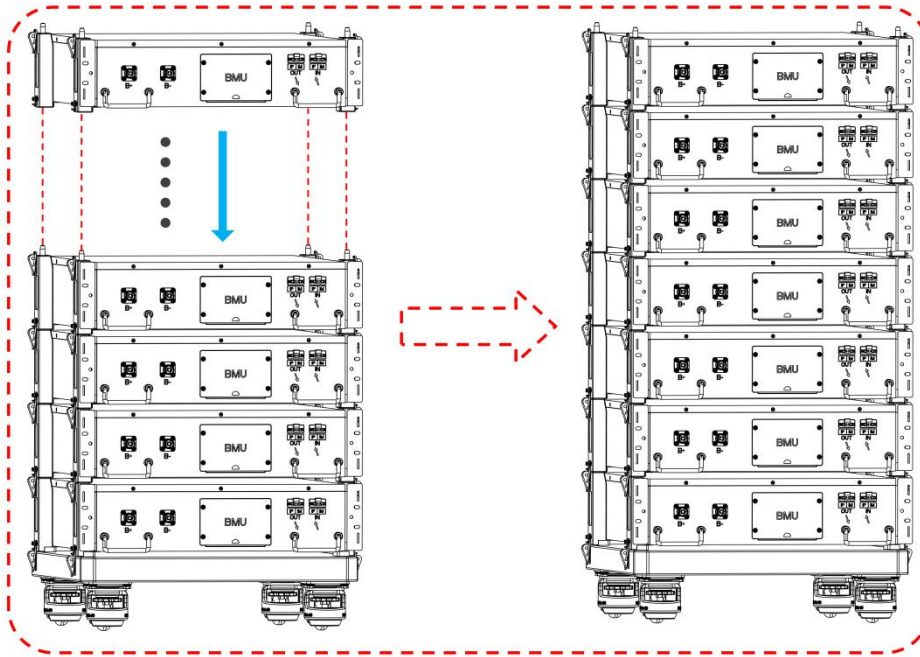

Figure 3.5-5

Step 5:

Similarly, in the HV PACK battery system, the mounting brackets around the control box need to be fixed by "limiting columns", "limiting holes" and "tower buckles", and ensure that the control box is not loose;

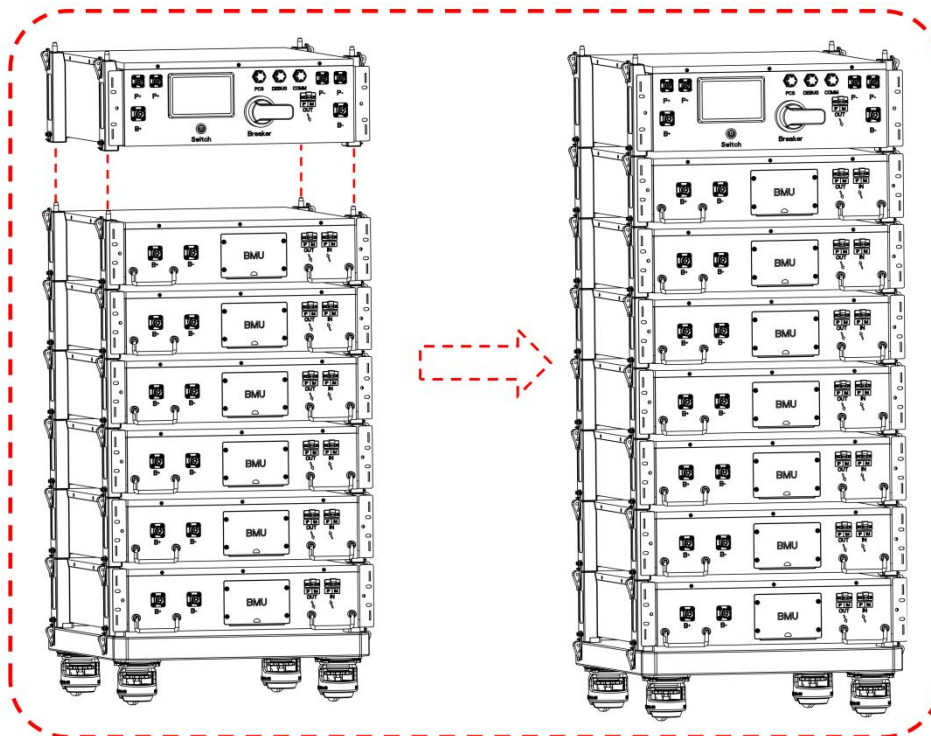

Figure 3.5-6

Step 6:

After the battery system is installed, check whether it is installed horizontally and firmly. If it is tilted or shaking, adjust the installation status of the battery system by rotating the adjustment gear.

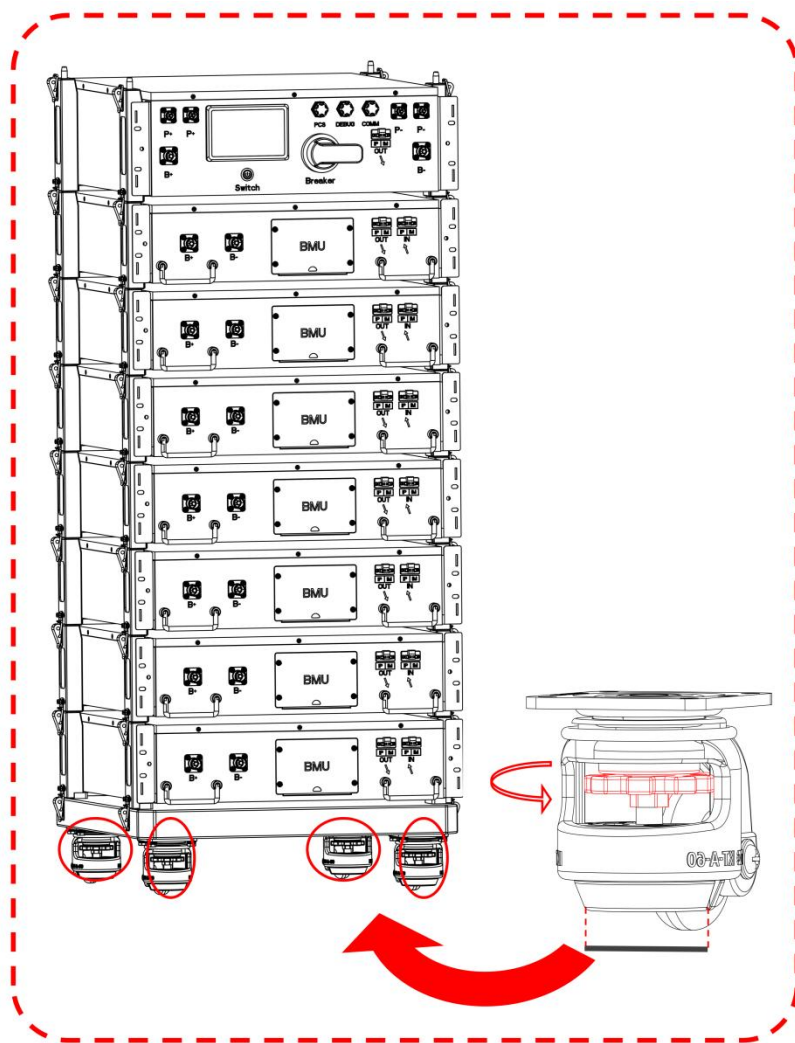

Figure 3.5-7



Notice:

Make sure the control box is always located above the battery. Do not install the battery on top of the control box. When placing the battery base, battery or control box, make sure the upper and lower holes are aligned.

3.6 Electrical Connections



Danger:

1. Safe power-off operation

Before performing any operation on the equipment in the battery system, make sure that the equipment is completely powered off to prevent electric shock accidents ;

Strictly comply with the safety precautions in this manual and the safety signs on the equipment ;

2. Electrical connection specifications

During electrical connections, cables and component specifications that comply with local laws and regulations must be used ;

Cables of the same type should be bundled together and laid out separately from cables of different types to prevent them from getting tangled or crossed .

3. Precautions for crimping terminal blocks

When crimping the terminal, you must ensure that the conductor part of the cable is in full contact with the terminal ;

It is strictly forbidden to crimp the cable insulation together with the terminal block. Doing so may cause the equipment to fail to operate normally, or generate heat due to unreliable connection during operation, thereby damaging the inverter terminal block.



Notice:

1. Electrical connection operations are limited to professionals ;
2. The cable colors shown in the figure are for reference only. In actual operation, they should be selected according to specific circumstances ;
3. Ensure that the cable specifications used comply with local laws and regulations .

3.6.1 Single Battery System

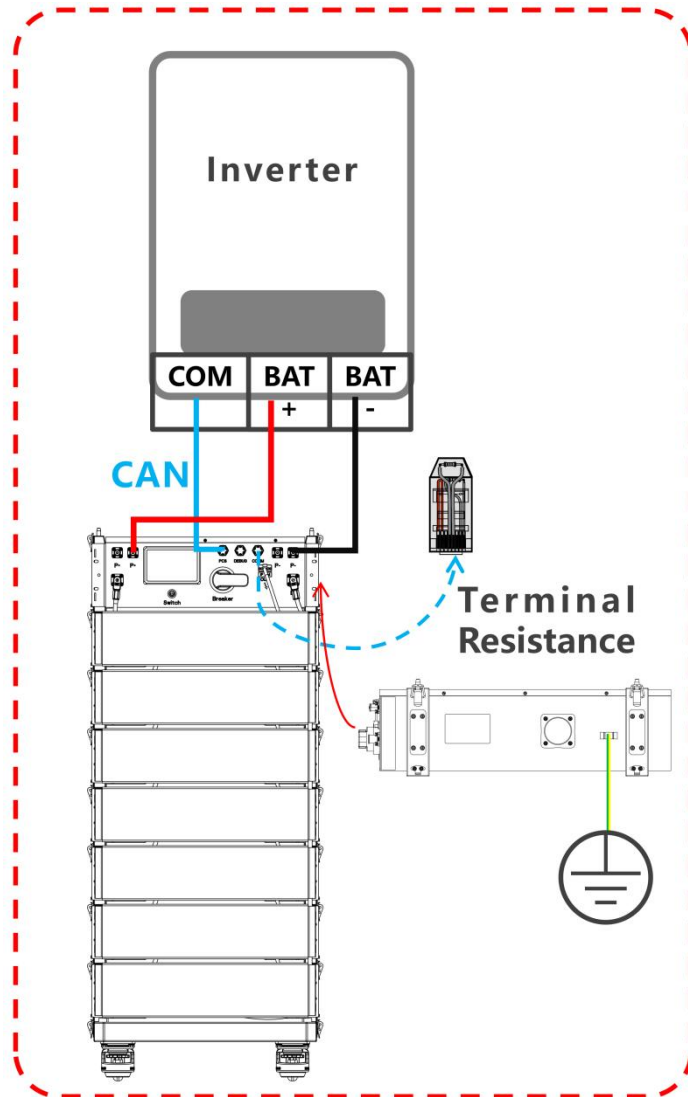

Figure 3.6.1

⚠ Notice:

1. The DEBUG port is for debugging. Please do not use this port when connecting the communication line .
2. Connect the PCS port to the inverter and install the terminal resistor on the COMM port ; note that if the terminal resistor is not installed, the battery system will not operate normally .

3.6.2 Cluster Battery System

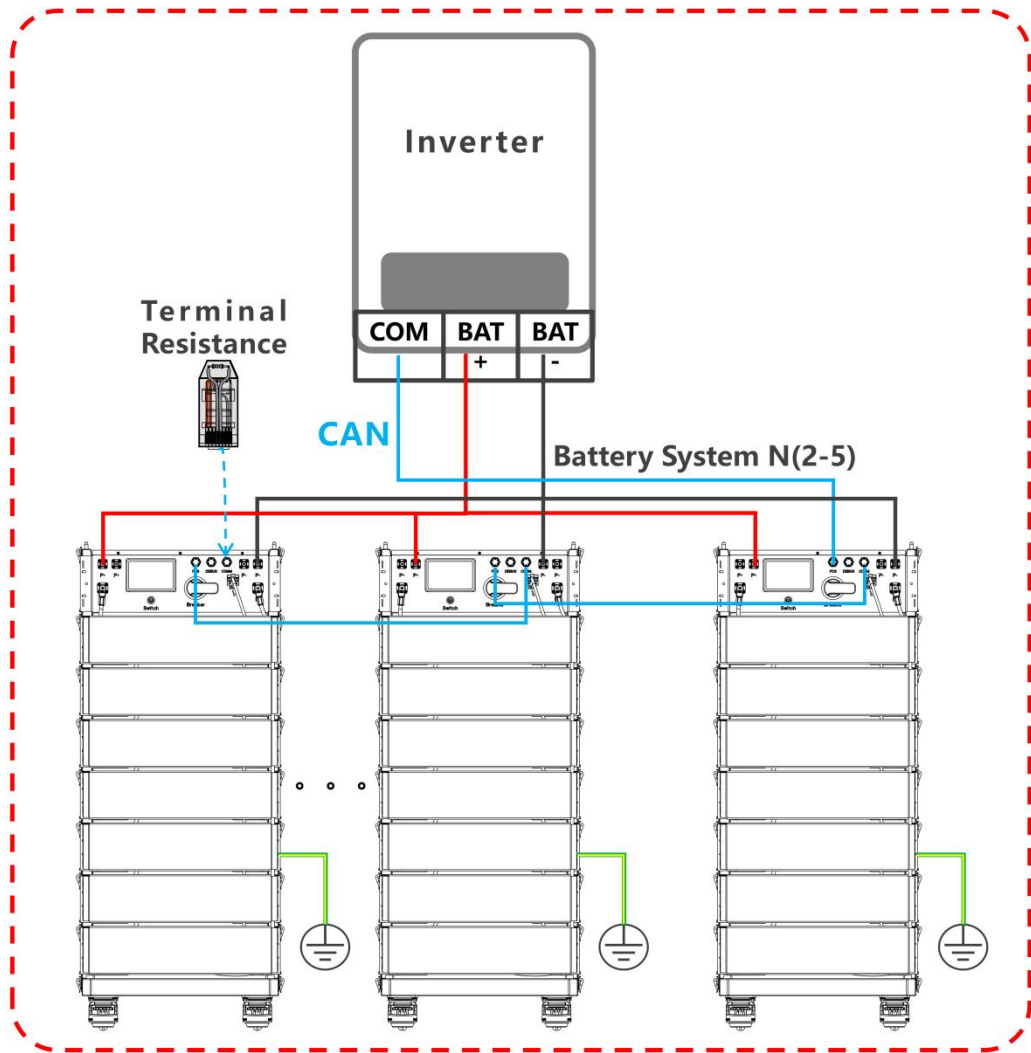

Figure 3.6.2



Notice:

1. The HVS battery system supports clustering of up to 5 battery systems ;
2. When clustering, the available power of each battery system must be consistent to ensure balanced and efficient operation of the system ;
3. Make sure the "PCS" communication port of battery system 1 is connected to the inverter . This is the port used to control the communication between the cluster battery system and the inverter .
4. Another "COMM" communication port of battery system 1 is used for battery cluster connection ;
5. For battery system N (N represents the last battery system) , make sure that the terminal resistor is installed on its "COMM" communication port ;

6. The DEBUG port is for debugging. Please do not use this port when connecting the communication line .

 **Illustrate:**

Installing a terminal resistor is essential to maintain the integrity of the communication line signal, which can prevent signal reflection and attenuation. If the "COMM" port is not equipped with a terminal resistor, it may cause abnormal communication of the battery system, thus affecting the overall operation of the energy storage system.

3.6.3 Power Line Connection

Internal power line: (completed at the factory)

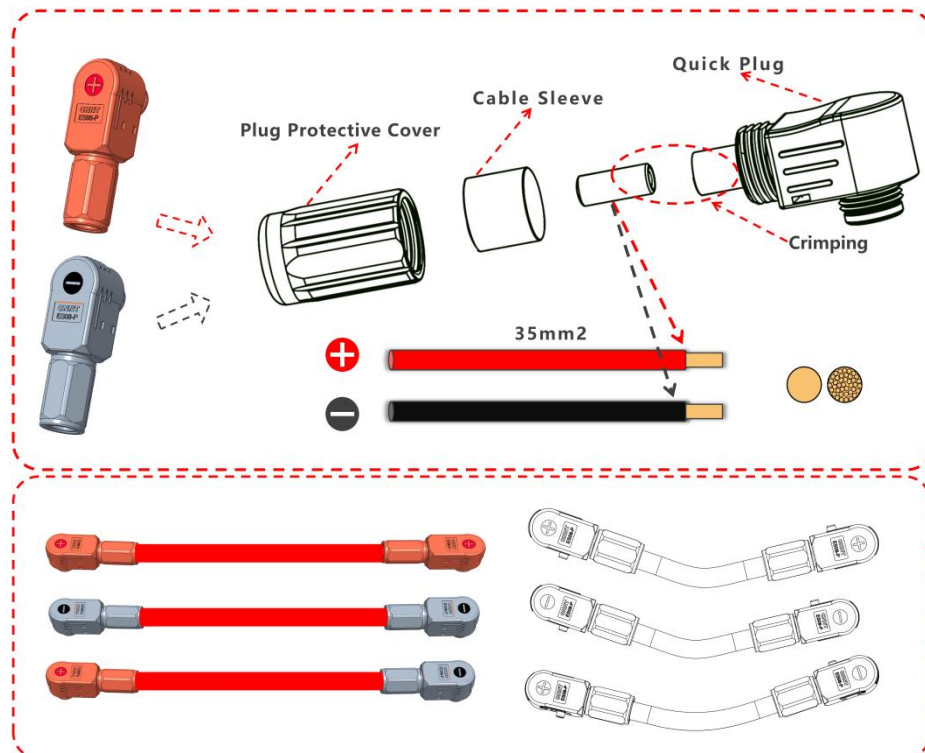

Figure 3.6.3-1

Battery pack power connection: (series)

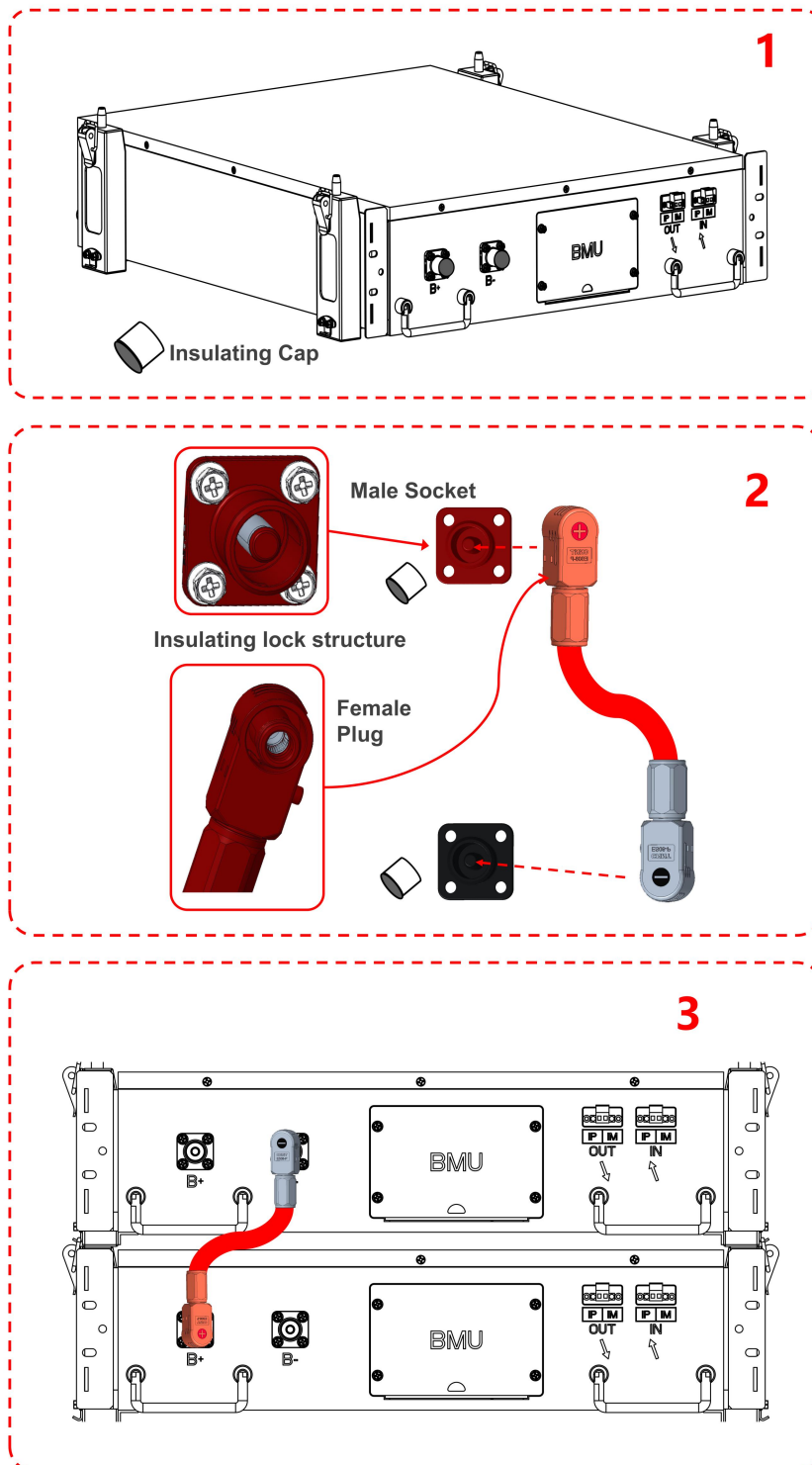

Figure 3.6.3-2



Description:

During the battery module connection operation, the insulated protection caps installed at the B+, B-, P+ and P- ports of the battery system should be removed firstly, and then the upper and lower modules can be quickly connected through the quick-connect connectors.

The system adopts the energy storage special quick plug connector with double safety protection characteristics:

Firstly, its insulation resistance value is $\geq 1000M \Omega$, providing reliable high-grade insulation protection;

Secondly, the female socket is specially designed with an anti-touch insulation contact point, which effectively prevents personnel's fingers from directly contacting the electrically charged parts through the physical isolation structure, thus guaranteeing the operation safety from the dual dimensions of structural design and electrical performance.

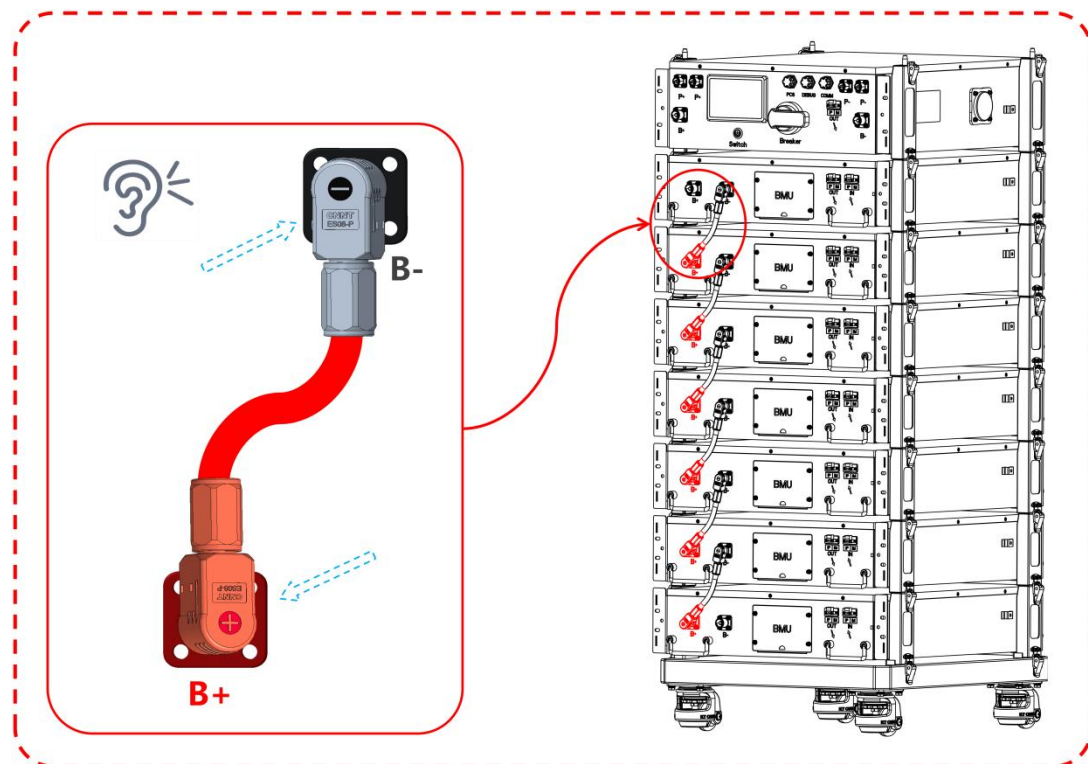

Figure 3.6.3-3

Battery pack communication connection: (BMU-daisy chain communication)

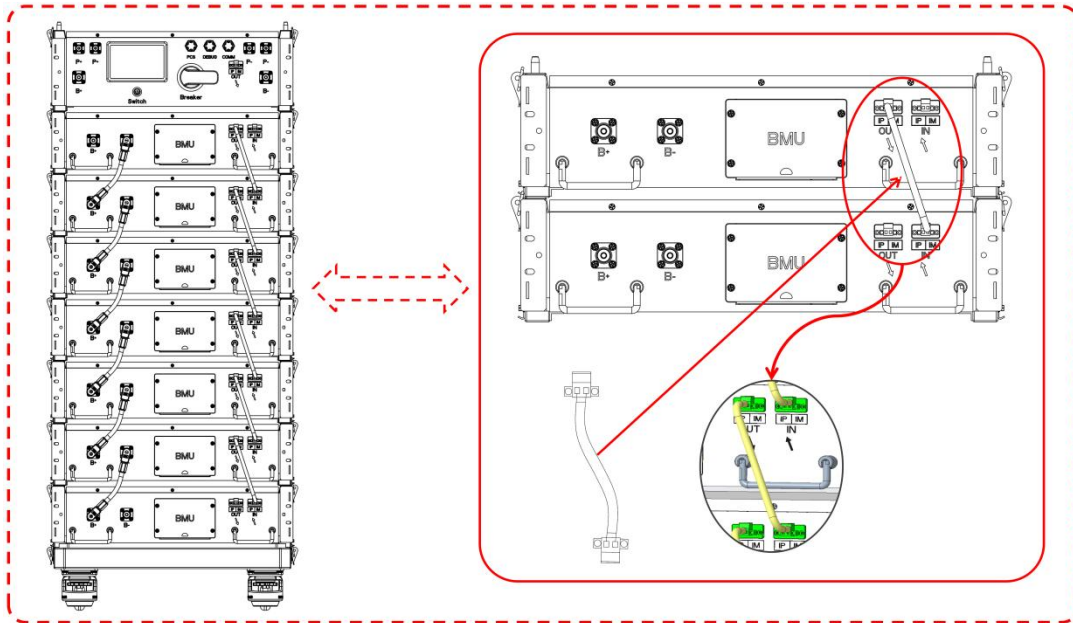



Figure 3.6.3-3

Battery Pack Communication Line Interface Definition Table

Serial Number	Interface	Description
1	IP-OUT	Daisy chain output positive
2	IM-OUT	Daisy chain output negative
3	IP-IN	Daisy chain input positive
4	IM-IN	Daisy chain input negative

Table 3.6.3

 **Note:** Daisy chain communication harnesses use unshielded twisted pair wires;

Connection between battery box and control box:

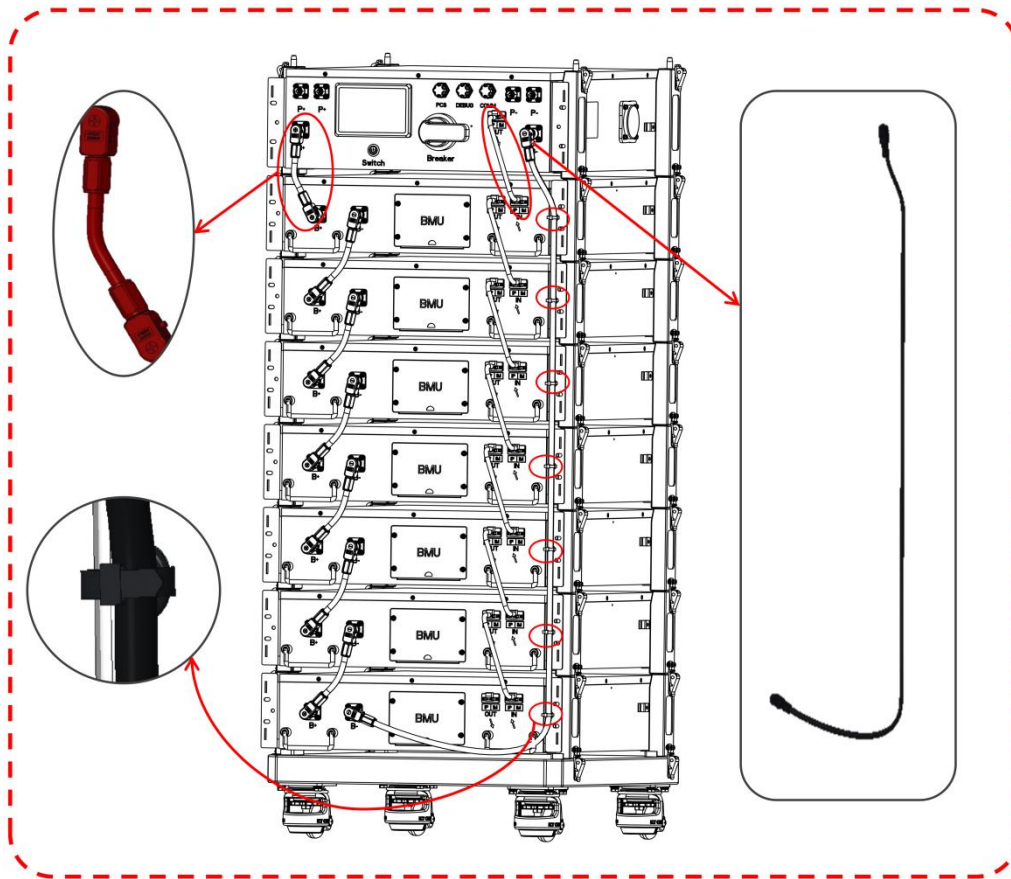

Figure 3.6.3-4



Notice:

1. "B+" on the high-voltage control box is connected to the positive pole of the battery box, and "B-" is connected to the negative pole of the battery box;
2. The "OUT" communication port on the high-voltage control box is the communication connection point between the BCU and BMU in the battery system;
3. The "B-" power connection cable needs to be tied with a cable tie at each battery box to secure the cable.

Install the battery box protective cover:

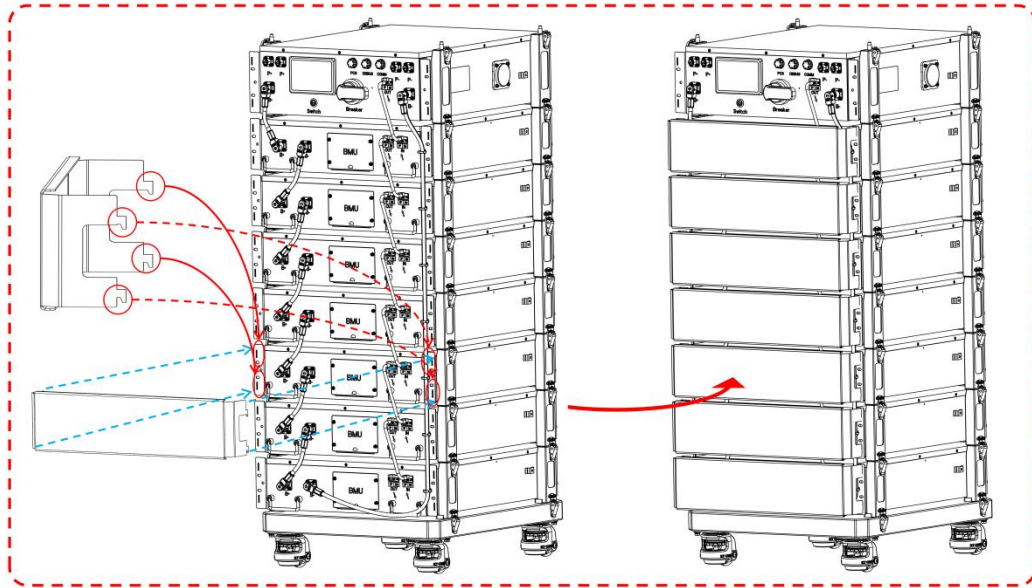

Figure 3.6.3-5

3.6.4 Communication Line Connection



Notice:

1. The user should decide whether to use the communication cable that comes with the inverter based on the installation requirements, and refer to the user manual for cable specifications and connection methods;
2. Purchase the communication cables yourself or ask the manufacturer to provide them . It is recommended to use standard Ethernet cables with RJ45 crystal connectors as the connection solution.

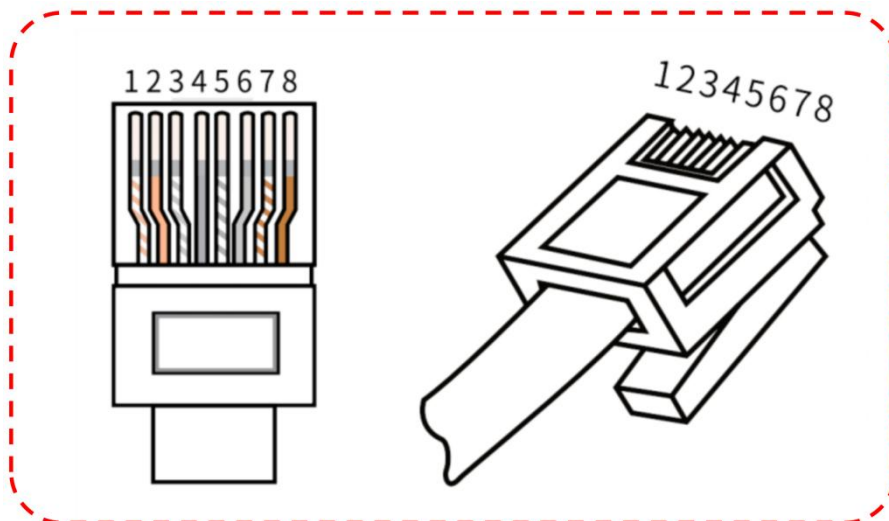

Figure 3.6.4

Port Definition Table

PIN	DEBUG	PCS	COMM
1	CAN0H	CAN0H	NC
2	CAN0L	CAN0L	NC
3	CAN1_GND	CAN1_GND	CAN1_GND
4	CAN1H	CAN1H	CAN1H
5	CAN1L	CAN1L	CAN1L
6	RS485G_1	DIH_IN2	HSS8
7	RS485A_1	GND	GND
8	RS485B_1	GND	GND

Table 3.6.4-1



Notice:

This chapter only explains the definition of the communication port. Be sure to install the battery system terminal resistor to avoid cluster faults and ensure the normal operation of the system .

Serial number	Name	Illustrate
1	CAN0H CAN0L	Function debugging and upgrading
2	CAN1_GND CAN1H CAN1L	Connect to inverter communication or battery cluster communication
3	RS485G_1 RS485A_1 RS485B_1	Connect external RS485 communication equipment
4	DIH_IN2	High level signal input detection, i.e. battery cluster signal detection
5	HSS8	High-side switch output, i.e. parallel cluster signal output
6	GND	Signal Ground

Table 3.6.4-2

3.6.5 Protective Ground Connection

 **Notice:**

1. Protective ground wire, recommended specifications: Type: outdoor single-core copper wire, conductor cross-sectional area: 6mm² ;
2. Make sure the cables are fixed and not loose after crimping.
3. After the battery stack is completed, the protective ground wire should be connected first to ensure safety, and when dismantling the battery system, the protective ground wire should be removed as the last step.

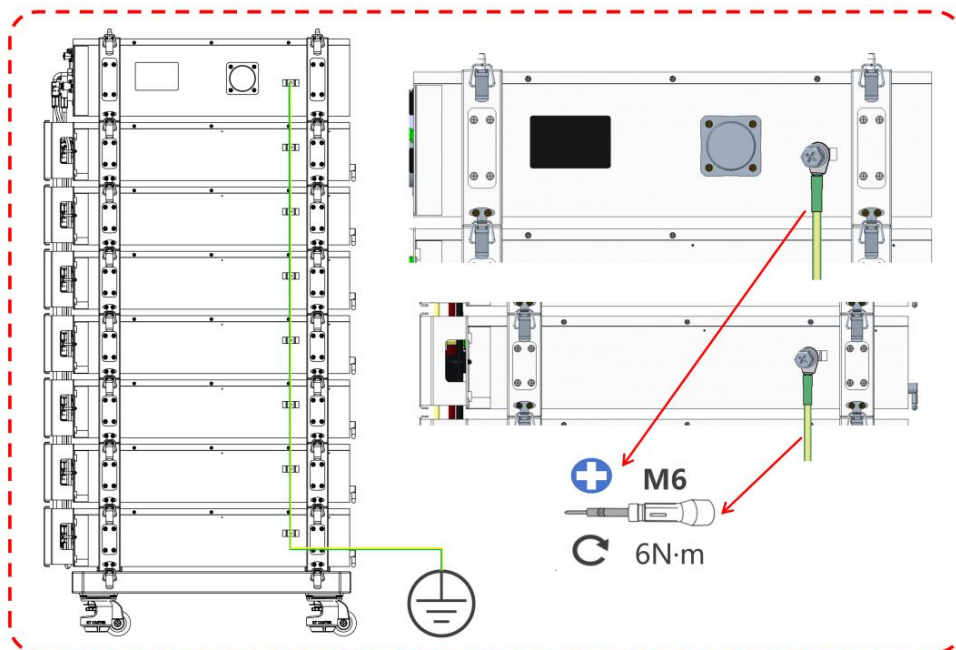

Figure 3.6.5

3.6.6 External Connection Lines

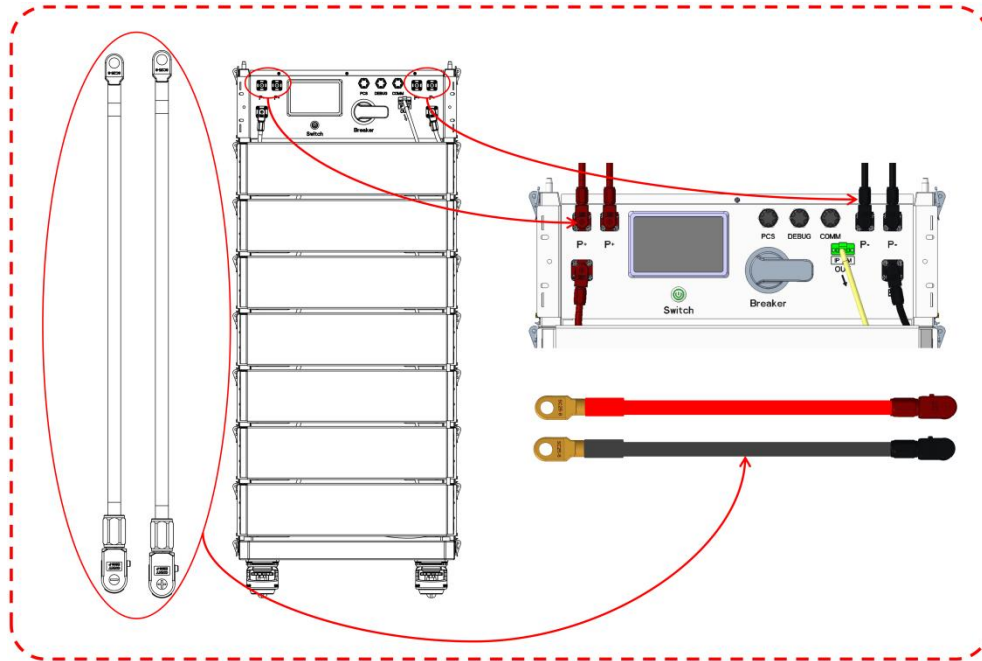

Figure 3.6.6

3.6.7 Electrical System Connection

 **Note:** Refer to Appendix B, C, and D.

04 Operation & Maintenance

 **Danger:**

Please use special protective equipment and special insulating tools to avoid electric shock or short circuit.

 **Notice:**

1. During the power-on process, you should observe while powering on. If you find any abnormal phenomenon, immediately disconnect the battery and find out the cause. You can continue to power on after solving it.

2. After battery installation and commissioning, or when the battery is completely discharged, please recharge the battery in time, otherwise the battery may be damaged due to over-discharge.

4.1 Check Before Power On

Inspection items and acceptance criteria

Serial Number	Inspection Items	Inspection Standards
1	System installed	Correct and reliable installation
2	Reasonable cable layout	Reasonable cable layout to meet user requirements
3	Cable ties are beautiful	The cable ties should be evenly spaced and no sharp corners should be left at the cut
4	Reliable grounding	The ground connection is correct, firm and reliable
5	Disconnect switch	The "inverter" and all switches connected to the battery are in the "OFF" state
6	Cable connection in place	The DC line, AC line and communication line are connected correctly and firmly.
7	Seal unused terminals and connectors	Install waterproof covers on unused terminals and interfaces
8	The installation environment meets the requirements	Reasonable installation space and clean environment

Table 4.1

4.2 Boot Steps

Step 1: Use a multi-meter to confirm that the grid voltage is within the predetermined range;

Step 2: Open the circuit breaker between the inverter and the battery;

Step 3: Open the battery circuit breaker; the "Breaker" between the battery systems needs to be opened in sequence; (Sequence: from nearest to farthest, switch on the circuit breaker on the control box of the master first, then switch on the remaining slave circuit breaker on the control box).

Step 4: Press the battery power button "SWITCH"; if it is a cluster system, before the first cluster, make sure that the voltage difference between the battery systems does not exceed 5V, then press the power button "SWITCH" between the battery systems one by one, and wait for 5 minutes for the stabilization period;

Step 5: Please power on the inverter according to the instructions in the

inverter user manual to start the inverter in the system.

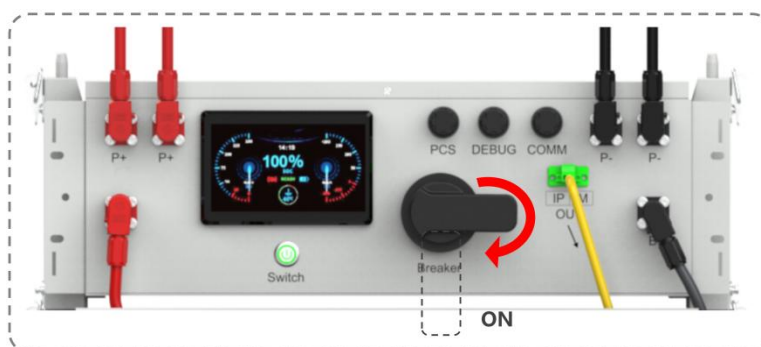

Figure 4.2-1

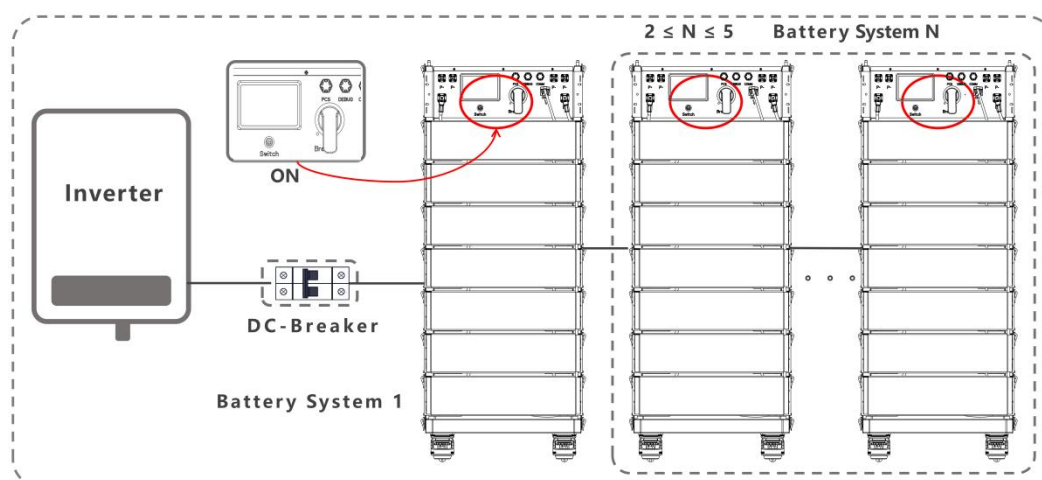

Figure 4.2-2

4.3 Shutdown Steps

 **Danger:**

When shutting down the battery system, please strictly follow the battery system power-off requirements to prevent damage to the battery system.

Step 1: Please follow the instructions in the inverter user manual to perform power-off operations to shut down the inverter in the system;

Step 2: In the cluster system, press the power button "SWITCH" on the battery system one by one to ensure that the indicator light of each "SWITCH" is off.

Step 3: If it is a cluster system, disconnect the circuit breakers between the battery systems one by one; (Sequence: from far to near, disconnect the circuit breaker on the slave control box first, and disconnect the circuit breaker of the

master control box last).

Step 4: Disconnect the circuit breaker between the inverter and the battery;



Description:

Instructions for safe disassembly operation of the battery system after the system is switched off:

Firstly, keep the power-off state static for more than 10 minutes to ensure that the energy storage system is fully discharged;

Then use a multi-meter to confirm that the inverter and battery system are not charged;

When dismantling the battery, after unplugging the quick-connect cable, the protective insulating cap must be tightly mounted on the female socket of the battery box and the high-voltage control box, so as to establish a physical isolation barrier between the electrified parts and the operating environment through the sealing structure, and to block the risk of the human body coming into contact with the electrified terminals.

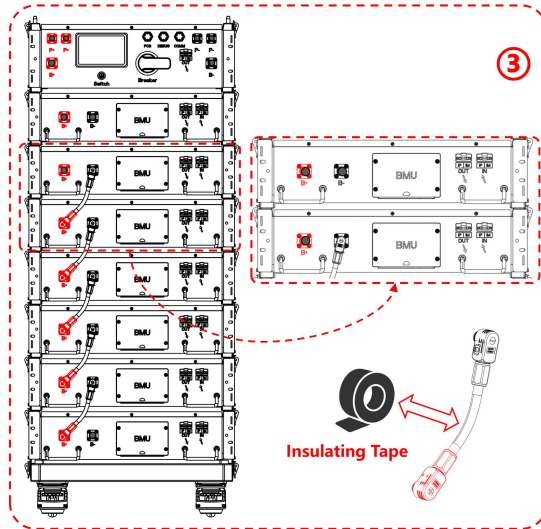
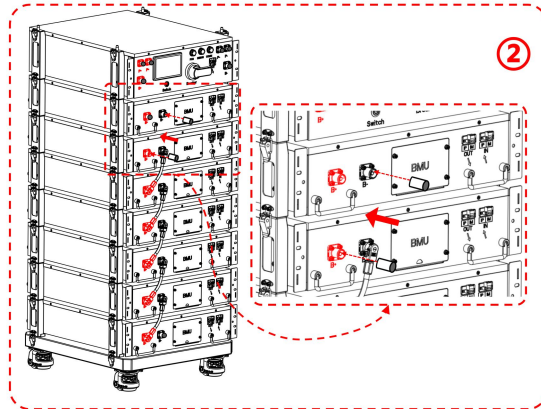
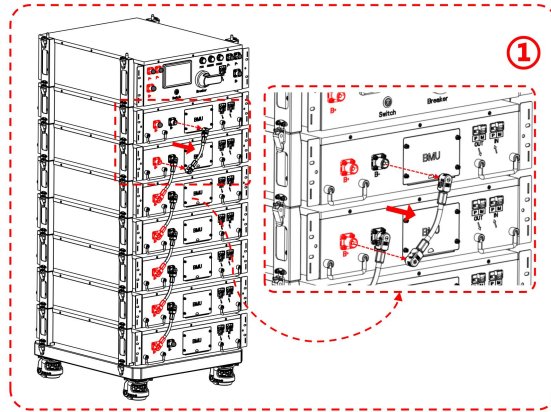

 **Note:**

1. When unplugging the quick-plug cable, it is strictly forbidden to unplug only one end of the plug while leaving the other end of the plug in the socket of the voltage box or battery pack;
2. After the cable is unplugged, the two ends of the quick plug on the cable must be tightly wrapped with insulating tape.

4.4 Mobile APP

 **Note:** After the battery system is powered on, you can view the detailed information of the battery on the "UDAN HESS" on the mobile phone.

Step 1: Download the “ UDAN HESS ” APP;

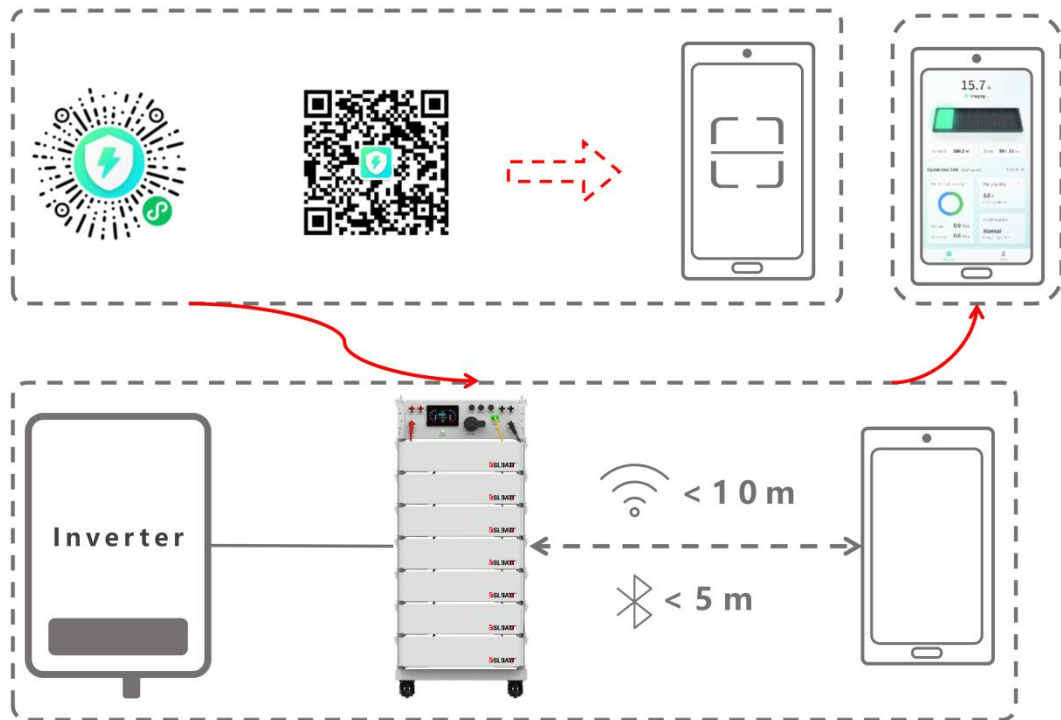

Figure 4.4-1

Step 2: Log in/register an account;

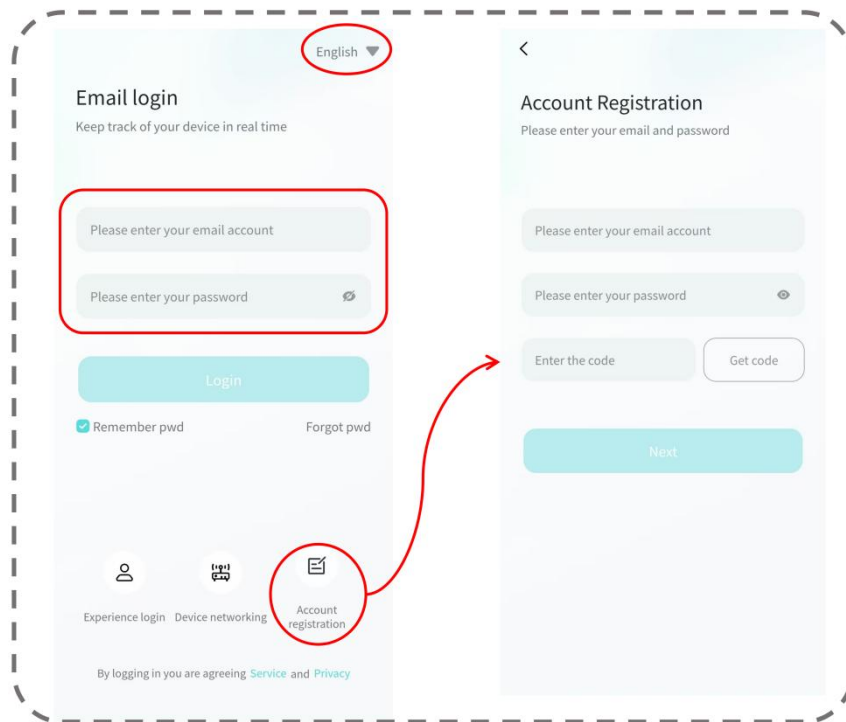

Figure 4.4-2

Step 3: Add device/connect device to the network;

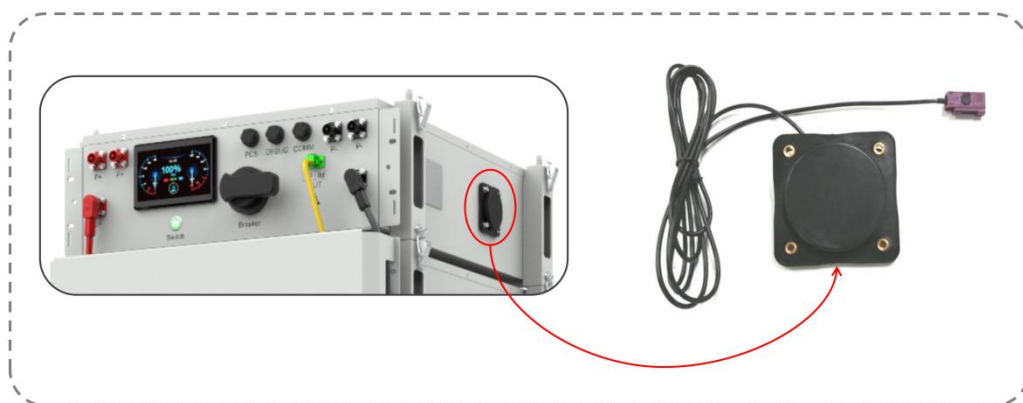



Figure 4.4-3

 **Description:** GPRS special waterproof antenna developed for lithium battery pack, suitable for wireless data transmission;

 **Note:** It is strictly forbidden to dismantle the antenna without permission, which may cause irreversible damage. The antenna must not be shielded by metal materials, and at least one direction must be unblocked, otherwise the signal strength will be affected.

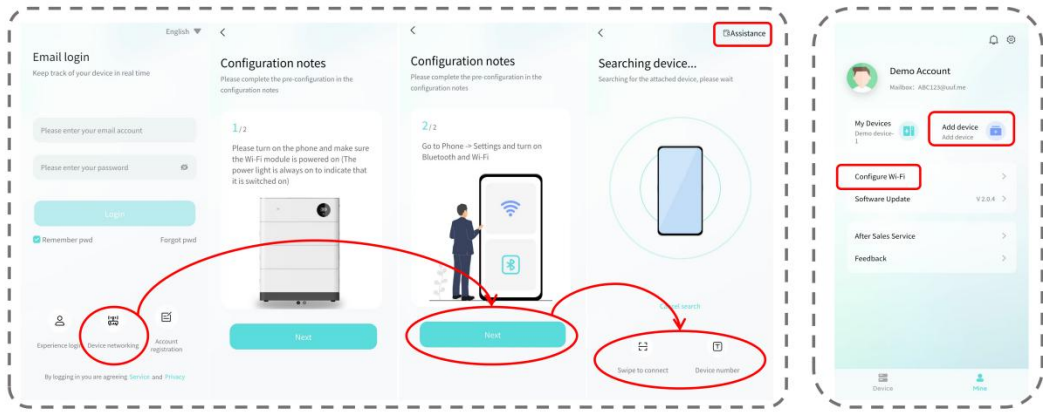



Figure 4.4-4

 **Note:** Connect by scanning the QR code or inputting the device serial number to correctly configure the battery;

 **Note:** This device does not support 5G band, so please make sure to connect to a WiFi network with 2.4G band.

Step 4: Check battery status;

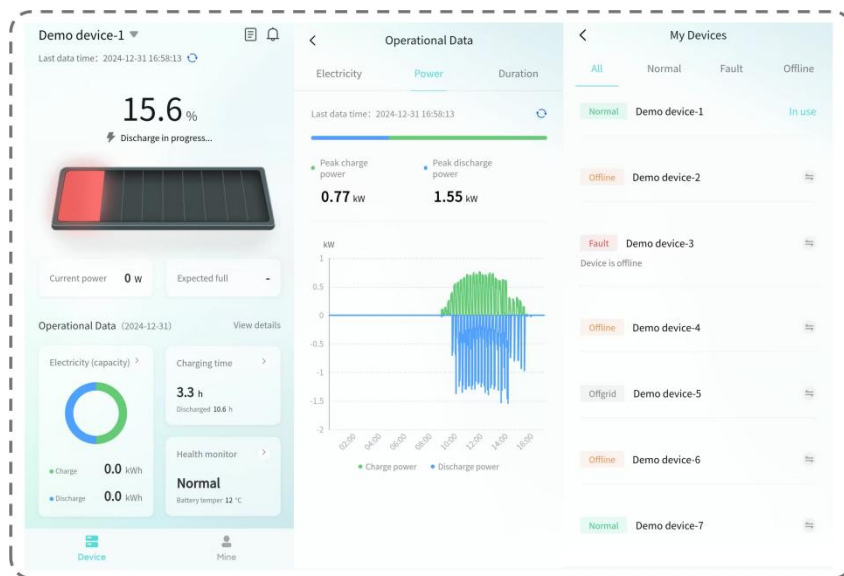

Figure 4.4-5

4.5 PC-side Cloud Platform

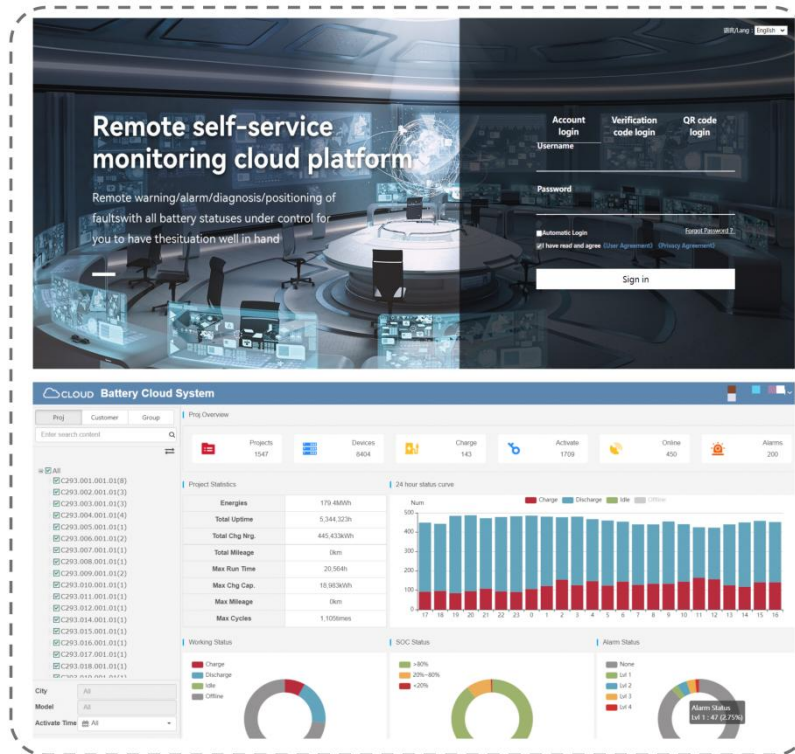

Figure 4.5

4.6 Battery Display

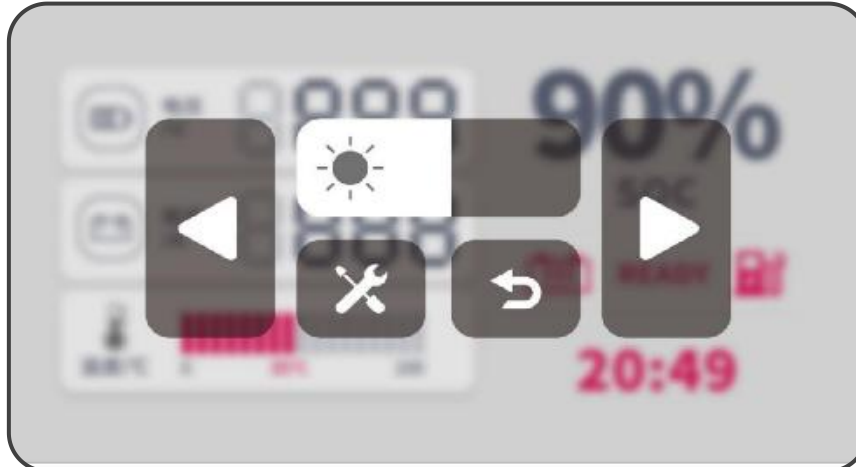



Figure 4.6-1



Figure 4.6-2

 **Note:** Battery Management System (BMS) information can be directly read and displayed on the display.

4.7 Battery Failure Handling

When the battery system fails, it may cause the system to shut down automatically or some functions to malfunction; please troubleshoot according to the following methods. If these troubleshooting cannot solve the problem, please contact the after-sales service center in time.

Notice:

When contacting after-sales service, please prepare the following information to quickly resolve the problem:

1. Battery information, such as serial number, software version, device installation time, fault occurrence time, fault occurrence frequency, etc.;
2. Equipment installation environment, such as weather conditions, etc. For installation environment recommendations, you can provide photos, videos and other documents to assist in analyzing the problem;
3. Equipment usage history, such as: frequency and duration of equipment use, number of times charged, maintenance status, etc., and also clearly specify the type of after-sales service, such as on-site repair, factory repair, or usage guidance.

Fault Alarm Processing Table

Fault name	Workaround
Charging monomer voltage is high Discharge cell voltage is high	After the battery has been idle for 0.5 hours, restart the discharge immediately. If the problem persists, please contact the after-sales service center
Charging cell voltage is low Discharge cell voltage is low	Restart charging immediately after the battery has been idle for 0.5 hours. If the problem persists, please contact the after-sales service center
High total charging voltage High total discharge voltage	After the battery has been idle for 0.5 hours, restart the discharge immediately. If the problem persists, please contact the after-sales service center
Total charging voltage is low Total discharge voltage is low	Restart charging immediately after the battery has been idle for 0.5 hours. If the problem persists, please contact the after-sales service center
Charging single cell voltage difference Discharge cell voltage difference	After restarting the battery, if the problem still exists, please contact the after-sales service center
Total charging voltage difference Discharge total pressure difference	After restarting the battery, if the problem still exists, please contact the after-sales service center
High temperature during charging High discharge temperature	<ol style="list-style-type: none"> 1. Check the installation environment temperature to ensure that the battery system installation temperature meets the battery operating temperature range; 2. Turn off the battery and restart the system after the temperature returns to normal.
Charging at low temperature Discharge low temperature	<ol style="list-style-type: none"> 1. Check the installation environment temperature to ensure that the battery system installation temperature meets the battery operating temperature range; 2. Turn off the battery and restart the system after the temperature returns to normal.

Charging temperature difference	1. Check the installation environment temperature, ensure that the battery system installation temperature meets the battery operating temperature range, and compare the temperature on the display.
Discharge temperature difference	2. Turn off the battery, wait for the temperature to recover, and then turn on the device. If the problem persists, please contact the after-sales service center.
Slow charge overcurrent	After waiting for 5 minutes, the system still fails to recover and needs to be restarted.
Continuous discharge overcurrent	If the problem persists, please contact the after-sales service center
SOC is too low	Restart the battery and charge it. If the problem persists, please contact the after-sales service center
Insulation leakage	Check whether the cable connections are normal, such as power lines, grounding lines, etc. If the problem persists, please contact the after-sales service center
Voltage cable missing	Please contact the after-sales service center
Thermal sensor cable is missing	Please contact the after-sales service center
Intranet communication failure	Please contact the after-sales service center
Precharge failed	Please contact the after-sales service center
Abnormal current	Please contact the after-sales service center
BMS initialization failure	After restarting the battery, if the problem still exists, please contact the after-sales service center
Relay failure	Please contact the after-sales service center

Table 4.7

 **Warning:** If any fault other than that in Table 4.7 occurs, please contact the after-sales service center directly.

4.8 Inspection and Maintenance

 **Note:**

The maintenance personnel of the energy storage equipment shall hold

the special operation certificate for electricians (China) or the electrician's licence in accordance with local regulations, complete the professional operation and maintenance training of the energy storage system and be proficient in the operation specification, and have perfect electrical safety protection and emergency response capability.

In Australia, **Sky Energy Investments Pty Ltd are authorised maintenance companies**



Warning:

- 1、 If you find any problem that may affect the battery system, please contact after-sales service immediately and do not disassemble it yourself;
- 2、 If you see the copper wire of the conductive wire exposed, do not touch it to avoid high voltage danger. Contact after-sales immediately. Do not disassemble it by yourself.
- 3、 In case of other emergencies, please contact after-sales immediately and follow their instructions, or wait for after-sales personnel to handle the situation on site.

Inspection and Maintenance Table

Maintenance content	Maintenance cycle
Check whether the battery system is loose. If so, tighten the corresponding position.	Every 6 months
Check if the shell is damaged. If so, please repaint it or contact the after-sales service center.	Every 6 months
Check whether the exposed wires are worn. If so, replace the corresponding cables.	Every 6 months
Check whether there is any debris around the battery to avoid affecting the heat dissipation of the battery.	Every 6 months
Check for water or pests to avoid long-term intrusion of the battery	Every 6 months

Table 4.8

4.9 Host Computer Monitoring



Notice:

1. Ensure that the host computer software used matches the battery system and is updated to the latest version;

2. Connect to the "DEBUG" port in the battery system to avoid connecting to the wrong port.



Figure 4.9-1

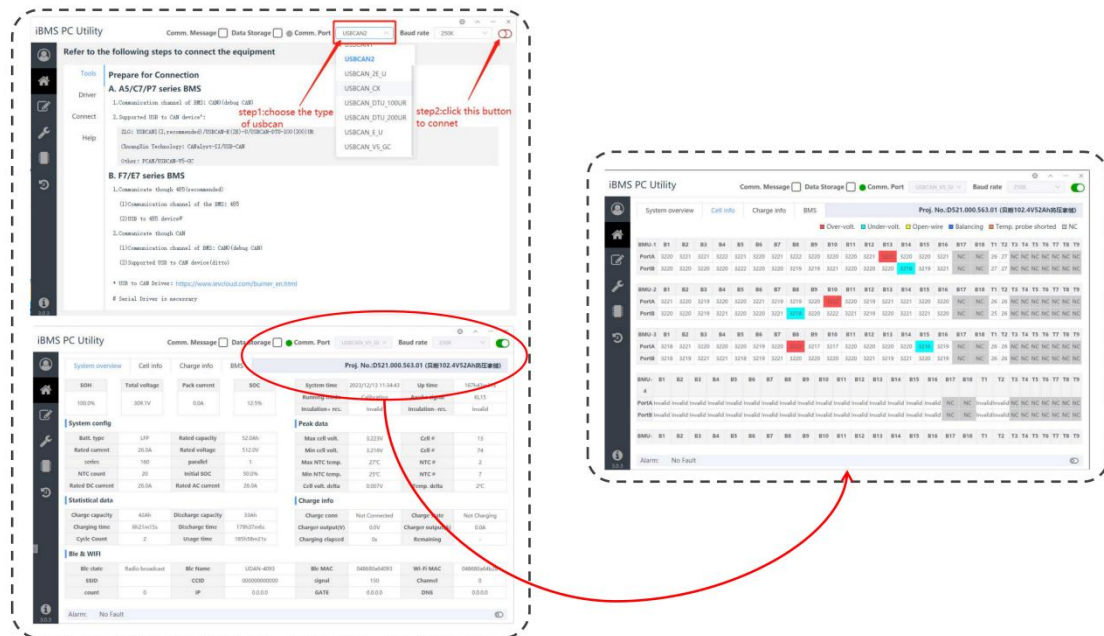

Figure 4.9-2



Illustrate:

After connecting the host computer to the battery system, users can monitor and extract a series of data covering the battery's SOC (state of charge percentage), SOH (healthy state percentage), etc.; including the total voltage of the battery system, the voltage of each cell, the total current, and the current data during charging and discharging. At the same time, users can also obtain the temperature of the battery cells and the whole, as well as the

battery's usage history, such as the number of charge and discharge cycles, and the accumulated charge and discharge amount. Battery safety information, such as fault codes and insulation status, is also searchable content. In addition, users can access detailed information on the system configuration and upgrade and debug the equipment.

05 Warranty Service

5.1 Warranty Period

In case of correct use of the product, the warranty period agreed in the commercial contract shall prevail.

5.2 Warranty Scope

During the warranty period, if the product is caused by quality problems, our company will repair or replace the product for free. Customers should reserve a reasonable response time for our company's repair, and the replaced product will be handled by our company. Customers need to show relevant proof of purchase of the product and ensure that the product trademark is clearly visible, otherwise our company has the right to not provide warranty guarantee.

5.3 Disclaimer

In the following situations, our company has the right not to provide quality assurance, but can still provide paid maintenance services.









1. The warranty period has expired;
2. Failure to provide relevant proof of product purchase;
3. Damage caused during transportation, loading and unloading;
4. Damage caused by improper installation, modification or dismantling by unauthorized personnel;
5. Damage caused by operation under abnormal conditions or environment;

6. Machine failure or damage caused by using non-Naton parts or software;

7. Failures caused by force majeure such as fire, earthquake, flood, etc.

Appendix

Appendix A-Marking Description

	Flammability risk
	Keep the battery away from open flame or ignition sources
	Recycling
	Danger of high voltages. Danger to life due to high voltages in the Energy storage system
	Danger. Risk of electric shock!
	CE certification
	Please read enclosed documentation carefully before using the product.
	This marking indicates that this product should not be disposed with other household wastes throughout the EU. To prevent possible harm to the environment or human health from uncontrolled waste disposal, recycle it responsibly to promote the sustainable reuse of material resources. To return your used device, please use the return and collection systems or contact the retailer where the product was purchased. They can take this product for environmental safe recycling.

Appendix B - System Connection Diagram

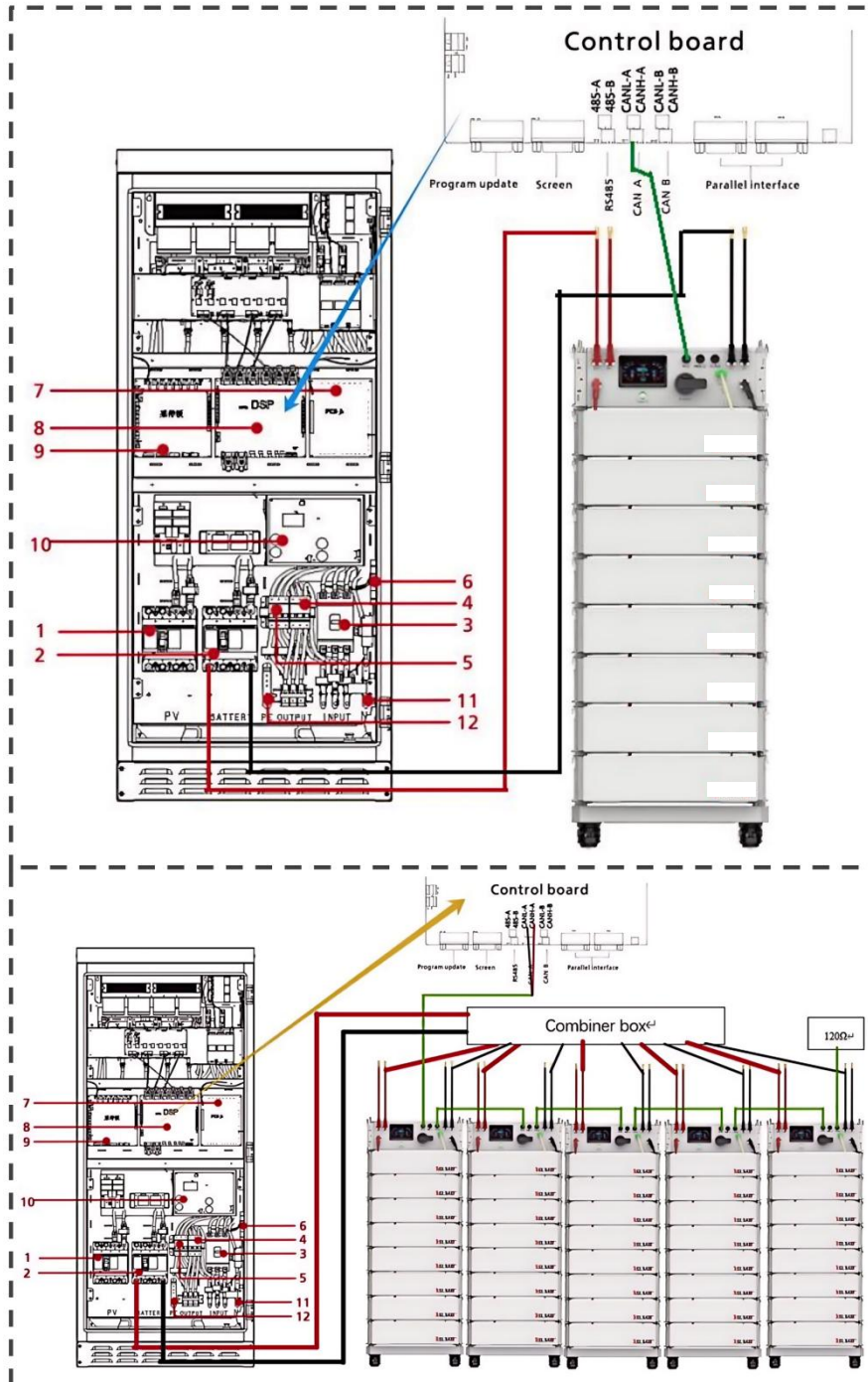

 **Illustrate:**

The figure shows the electrical system connection between Shenzhen Times ATESS's "HPS30" series and "HV PACK" battery; for detailed information and operating instructions of the inverter, please refer to the "ATESS" user manual.

Appendix C - System Connection Diagram

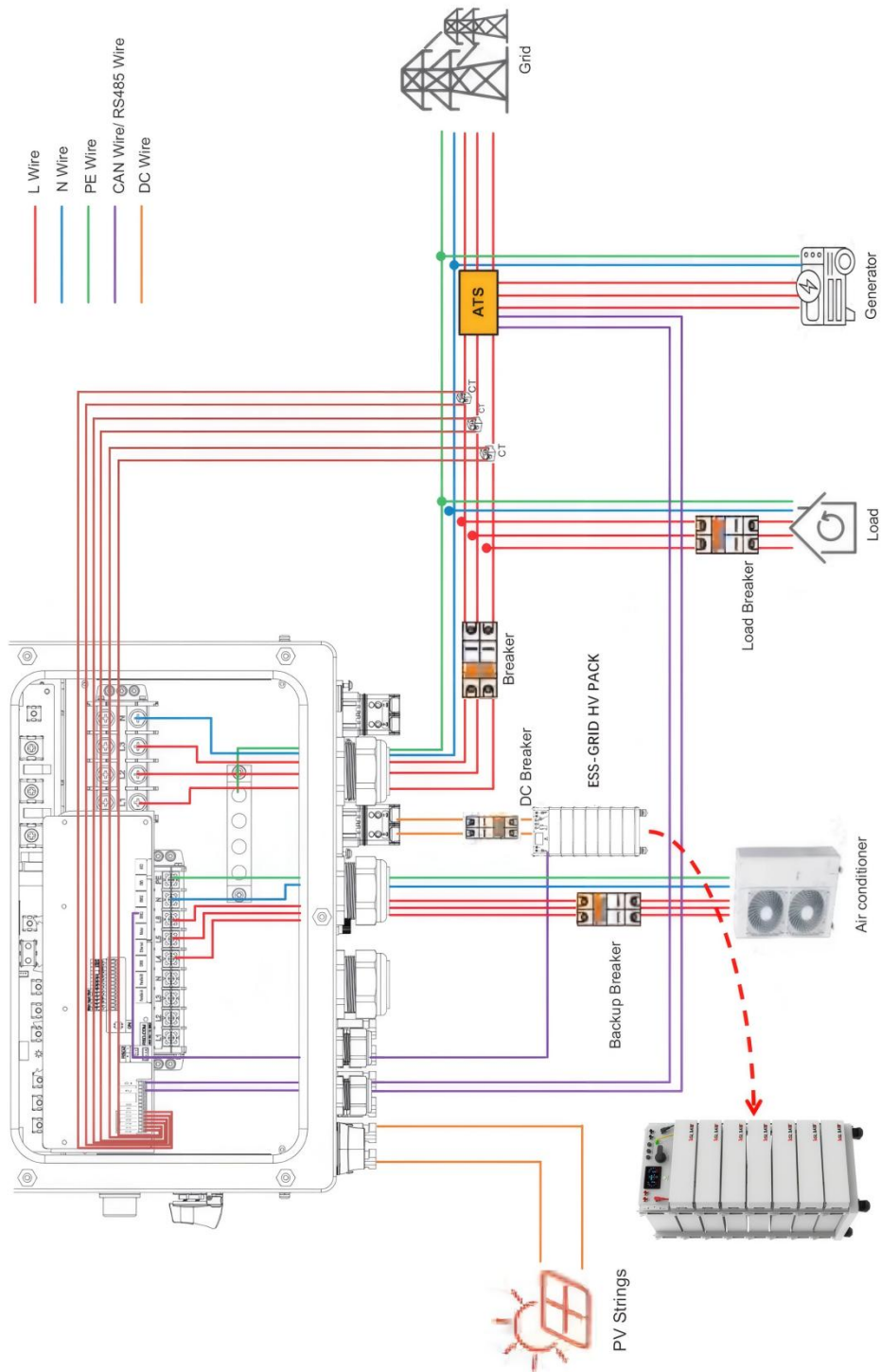

 **Illustrate:**

The figure shows the electrical system connection between the Jinlong inverter "S6-EH3P29.9~50K-H" series and the "HV PACK" battery; for detailed information and operating instructions of the inverter, please refer to the "Jinlong" user manual.

Appendix D - System Connection Diagram

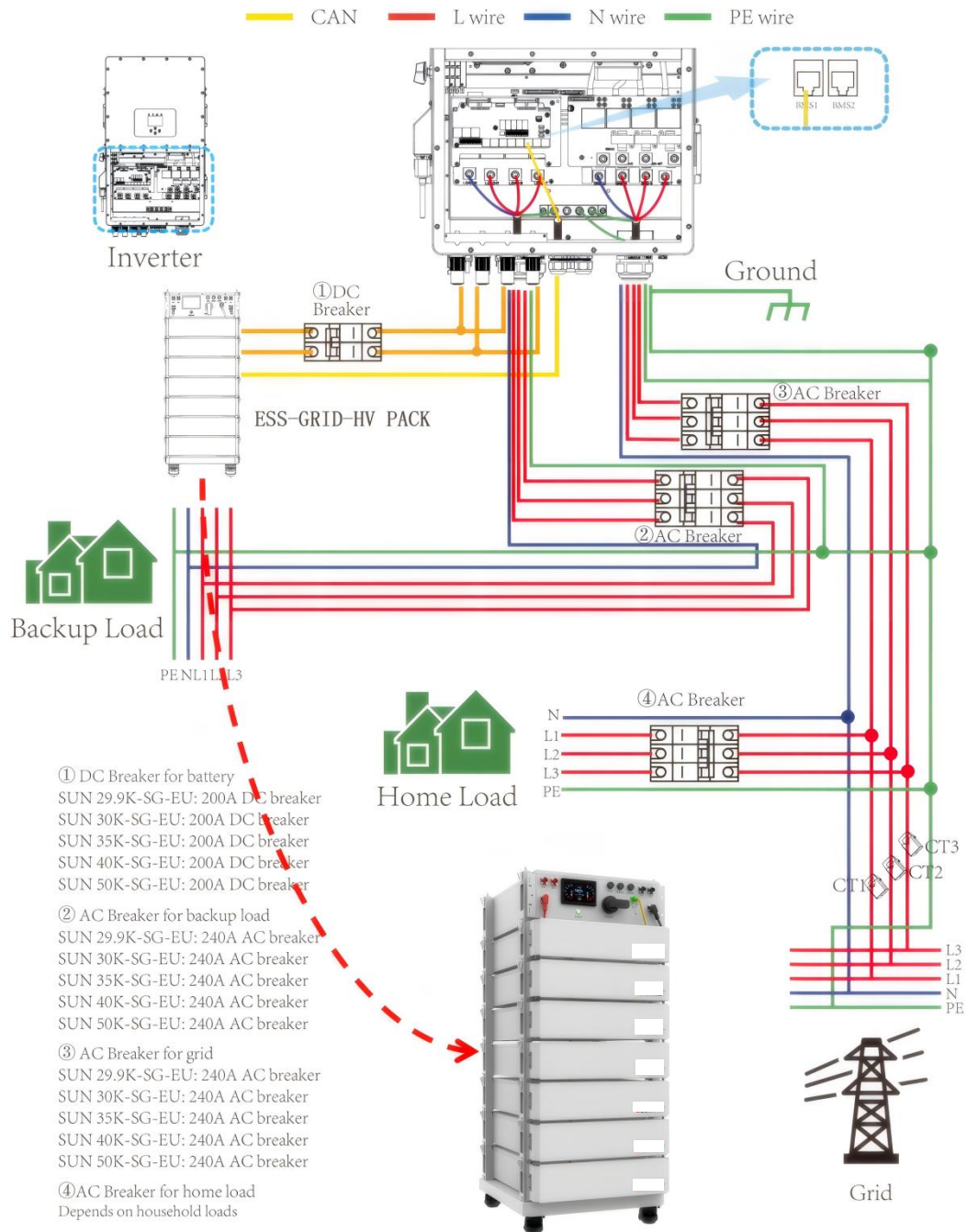

Illustrate:

The figure shows the electrical system connection between the Deye inverter "SUN-29.9-50K-SG01LP3-EU-BM3" series and the "HV PACK" battery; for detailed information and operating instructions of the inverter, please refer to the "Deye" user manual.



Sky Energy Investments Pty Ltd
1300 787 488
4/4 Bridge Rd Keysborough VIC Australia
team@skyenergysystems.com.au