



# Hybrid Inverter

SUN-29.9K-SG01HP3-AU-BM3

SUN-30K-SG01HP3-AU-BM3

SUN-35K-SG01HP3-AU-BM3

SUN-40K-SG01HP3-AU-BM4

SUN-50K-SG01HP3-AU-BM4

## User Manual

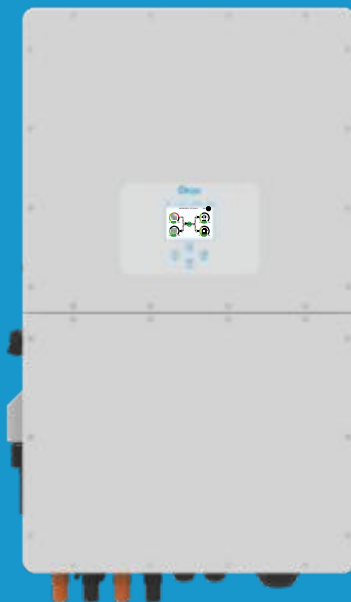

---

# Contents

<b>1. Safety Introductions</b>	01
<b>2. Product instructions</b>	02-05
2.1 Product Overview	
2.2 Product Size	
2.3 Product Features	
2.4 Basic System Architecture	
2.5 Maintenance of the System	
2.6 Product handling requirements	
<b>3. Installation</b>	05-25
3.1 Parts list	
3.2 Mounting instructions	
3.3 Battery connection	
3.4 Grid connection and backup load connection	
3.5 PV Connection	
3.6 CT Connection	
3.6.1 Meter Connection	
3.7 Earth Connection(mandatory)	
3.8 WIFI Connection	
3.9 Communication Connection	
3.10 Wiring System for Inverter	
3.11 Wiring diagram	
3.12 Typical application diagram of diesel generator	
3.13 phase parallel connection diagram	
<b>4. OPERATION</b>	26
4.1 Power ON/OFF	
4.2 Operation and Display Panel	
<b>5. LCD Display Icons</b>	27-40
5.1 Main Screen	
5.2 Solar Power Curve	
5.3 Curve Page-Solar & Load & Grid	
5.4 System Setup Menu	
5.5 Basic Setup Menu	
5.6 Battery Setup Menu	
5.7 System Work Mode Setup Menu	
5.8 Grid Setup Menu	
5.9 Generator Port Use Setup Menu	
5.10 Advanced Function Setup Menu	
5.11 Device Info Setup Menu	
<b>6. Mode</b>	40-41
<b>7. Limitation of Liability</b>	41-45
<b>8. Datasheet</b>	46-47
<b>9. Package and transport inverter</b>	47
<b>10. Disposing of the inverter</b>	47
<b>11. Appendix I</b>	48-49
<b>12. Appendix II</b>	50

## About This Manual

The manual mainly describes the product information, guidelines for installation, operation and maintenance. The manual cannot include complete information about the photovoltaic (PV) system.

## How to Use This Manual

Read the manual and other related documents before performing any operation on the inverter. Documents must be stored carefully and be available at all times.

**Contents may be periodically updated or revised due to product development. The information in this manual is subject to change without notice.** The latest manual can be acquired via [service@deye.com.cn](mailto:service@deye.com.cn)

## 1. Safety Introductions

### Safety signs



The DC input terminals of the inverter must not be grounded.



Surface high temperature, Please do not touch the inverter case.



5min

The AC and DC circuits must be disconnected separately, and the maintenance personnel must wait for 5 minutes before they are completely powered off before they can start working.



Prohibit disassembling inverter case, there existing shock hazard, which may cause serious injury or death, please ask qualified person to repair.



Please read the instructions carefully before use.



Do Not put it in the waste bin! Recycle it by licensed professional!

- This chapter contains important safety and operating instructions. Read and keep this manual for future reference.
- Before using the inverter, please read the instructions and warning signs of the battery and corresponding sections in the instruction manual.
- Do not disassemble the inverter. If you need maintenance or repair, take it to a professional service center.
- Improper reassembly may result in electric shock or fire.
- To reduce risk of electric shock, disconnect all wires before attempting any maintenance or cleaning. Turning off the unit will not reduce this risk.
- Caution: Only qualified personnel can install this device with battery.
- Never charge a frozen battery.
- For optimum operation of this inverter, please follow required specification to select appropriate cable size. It is very important to correctly operate this inverter.
- Be very cautious when working with metal tools on or around batteries. Dropping a tool may cause a spark or short circuit in batteries or other electrical parts, even cause an explosion.
- Please strictly follow installation procedure when you want to disconnect AC or DC terminals. Please refer to "Installation" section of this manual for the details.
- Grounding instructions - this inverter should be connected to a permanent grounded wiring system. Be sure to comply with local requirements and regulation to install this inverter.
- Never cause AC output and DC input short circuited. Do not connect to the mains when DC input short circuits.

## 2. Product Introductions

This is a multifunctional inverter, combining functions of inverter, solar charger and battery charger to offer uninterruptible power support with portable size. Its comprehensive LCD display offers user configurable and easy accessible button operation such as battery charging, AC/solar charging, and acceptable input voltage based on different applications.

### 2.1 Product Overview

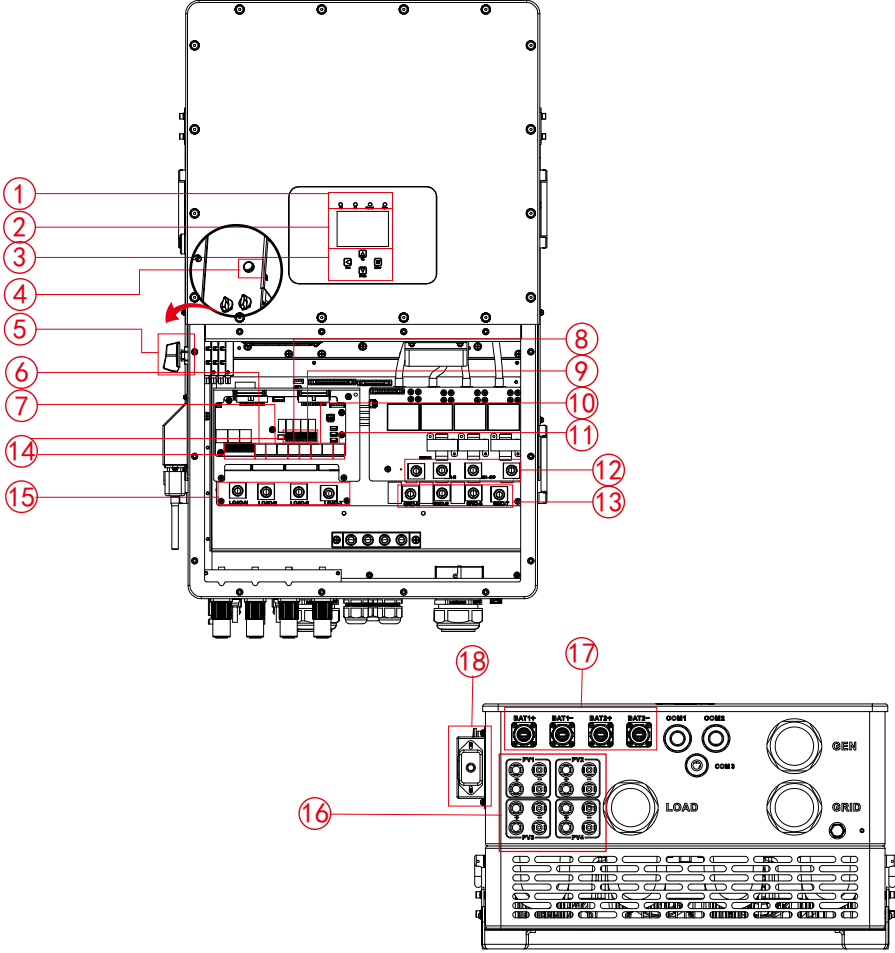

- |                        |                     |                    |
|------------------------|---------------------|--------------------|
| 1: Inverter indicators | 7: Parallel port    | 13: Grid           |
| 2: LCD display         | 8: CAN port         | 14: Function port  |
| 3: Function buttons    | 9: DRM port         | 15: Load           |
| 4: Power on/off button | 10: BMS port        | 16: PV input       |
| 5: DC switch           | 11: RS485 port      | 17: Battery input  |
| 6: Meter port          | 12: Generator input | 18: WiFi Interface |



## 2.3 Product Features

- 230V/400V Three phase Pure sine wave inverter.
- Self-consumption and feed-in to the grid.
- Auto restart while AC is recovering.
- Programmable supply priority for battery or grid.
- Programmable multiple operation modes: On grid, off grid and UPS.
- Configurable battery charging current/voltage based on applications by LCD setting.
- Configurable AC/Solar/Generator Charger priority by LCD setting.
- Compatible with mains voltage or generator power.
- Overload/over temperature/short circuit protection.
- Smart battery charger design for optimized battery performance
- With limit function, prevent excess power overflow to the grid.
- Supporting WIFI monitoring and build-in 2 strings for 1 MPP tracker, 1 string for 1 MPP tracker.
- Smart settable three stages MPPT charging for optimized battery performance.
- Time of use function.
- Smart Load Function.

## 2.4 Basic System Architecture

The following illustration shows basic application of this inverter.

It also includes following devices to have a complete running system.

- Generator or Utility
- PV modules

Consult with your system integrator for other possible system architectures depending on your requirements.

This inverter can power all kinds of appliances in home or office environment, including motor type appliances such as refrigerator and air conditioner.

## 2.5 Maintenance of the System

The inverter is low maintenance, however, it is important that at least twice a year (for dusty environments this may need to be carried out weekly) all the cooling fans, air ducts are cleaned and dust free. Check if there are no fault codes and Lithium battery communication is correct.

Weekly cleaning statement: Suggest micromesh filters as an available option.

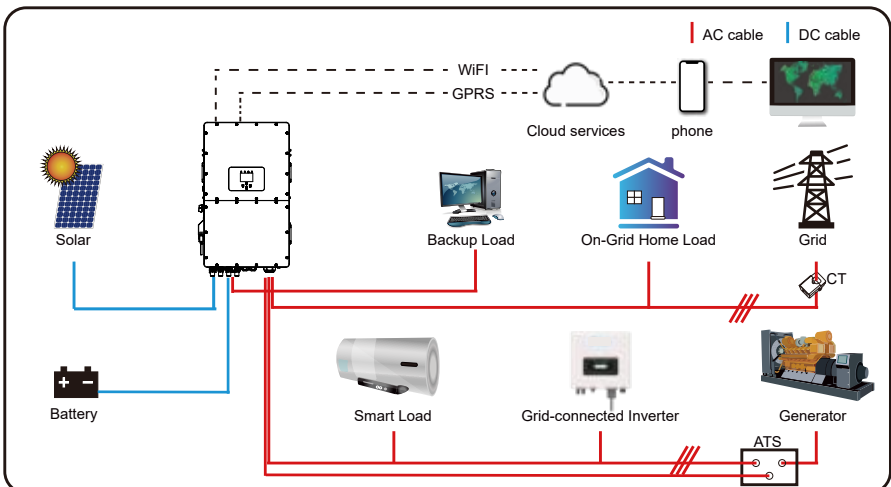

## 2.6 Product handling requirements

Two people stand on both sides of the machine, holding two handles to lift the machine.

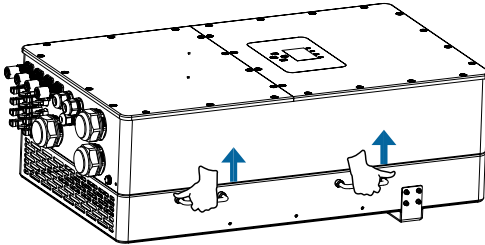

transport

## 3. Installation

### 3.1 Parts List

Check the equipment before installation. Please make sure nothing is damaged in the package. You should have received the items in the following package:

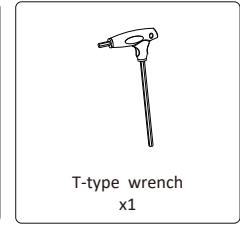
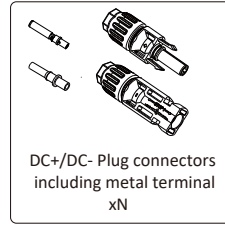
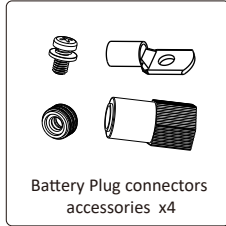
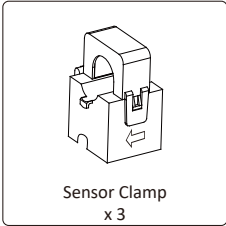
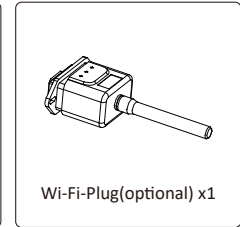
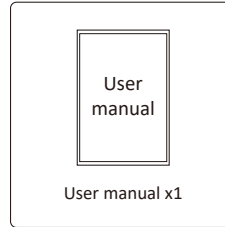
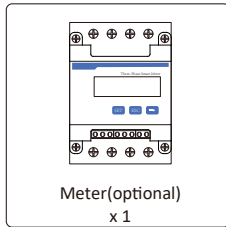
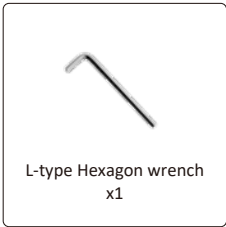
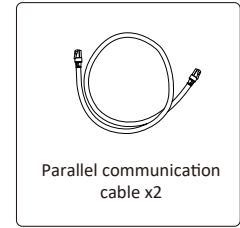
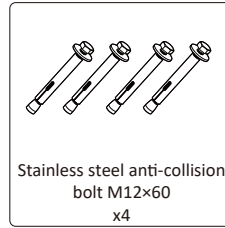
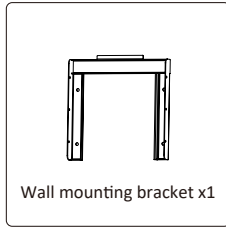
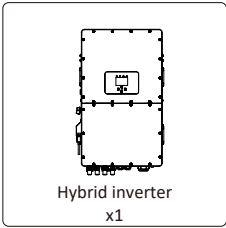

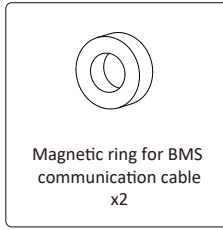
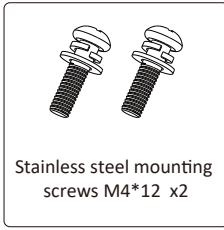

## 3.2 Mounting instructions

### Installation Precaution

This Hybrid inverter is designed for outdoor use(IP65), Please make sure the installation site meets below conditions:

- Not in direct sunlight
- Not in areas where highly flammable materials are stored.
- Not in potential explosive areas.
- Not in the cool air directly.
- Not near the television Antenna or antenna cable.
- Not higher than altitude of about 2000 meters above sea level.
- Not in environment of precipitation or humidity(>95%)

Please AVOID direct sunlight, rain exposure, snow laying up during installation and operation. Before connecting all wires, please take off the metal cover by removing screws as shown below:

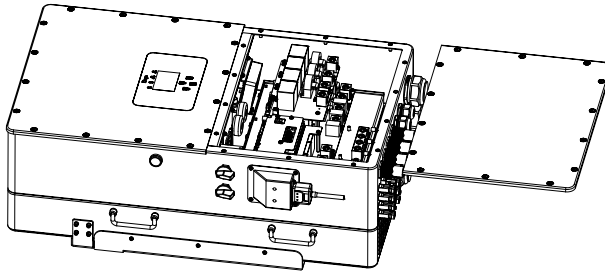

### Considering the following points before selecting where to install:

- Please select a vertical wall with load-bearing capacity for installation, suitable for installation on concrete or other non-flammable surfaces, installation is shown below.
- Install this inverter at eye level in order to allow the LCD display to be read at all times.
- The ambient temperature is recommended to be between  $-40\sim 60^{\circ}\text{C}$  to ensure optimal operation.
- Be sure to keep other objects and surfaces as shown in the diagram to guarantee sufficient heat dissipation and have enough space for removing wires.

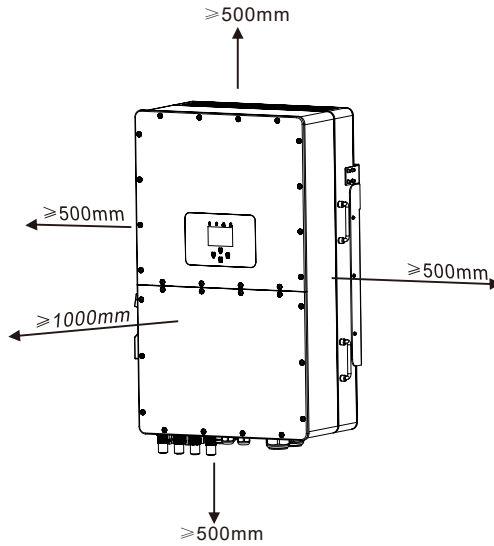

For proper air circulation to dissipate heat, allow a clearance of approx. 50cm to the side and approx. 50cm above and below the unit. And 100cm to the front.

## Mounting the inverter

Remember that this inverter is heavy! Please be careful when lifting out from the package. Choose the recommend drill head(as shown in below pic) to drill 4 holes on the wall, 62-70mm deep.

1. Use a proper hammer to fit the expansion bolt into the holes.
2. Carry the inverter and holding it, make sure the hanger aim at the expansion bolt,fix the inverter on the wall.
3. Fasten the screw head of the expansion bolt to finish the mounting.

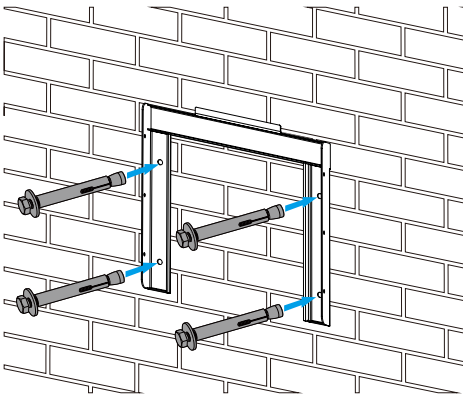

Inverter hanging plate installation

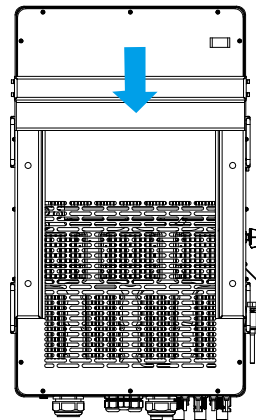

### 3.3 Battery connection

For safe operation and compliance, a separate DC over-current protector or disconnect device is required between the battery and the inverter. In some applications, switching devices may not be required but over-current protectors are still required. Refer to the typical amperage in the table below for the required fuse or circuit breaker size.

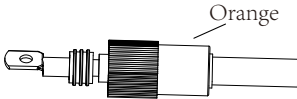

Pic 3.1 BAT+ plug connector

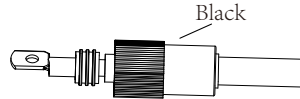

Pic 3.2 BAT- plug connector



**Safety Hint:**

Please use approved DC cable for battery system.

Model	Cross section (mm <sup>2</sup> )	
	Range	Recommended value
29.9/30/35/40/50kW	16.0~25.0 (6~4AWG)	16.0(6AWG)

Chart 3-2

The steps to assemble the battery plug connectors are listed as follows:

a) Pass the cable through the terminal. (as shown in picture 3.3)

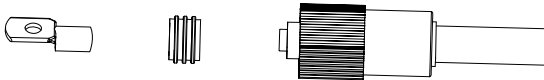

Pic 3.3

b) Put on the rubber ring. (as shown in picture 3.4)

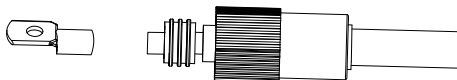

Pic 3.4

c) crimp terminals. (as shown in picture 3.5)

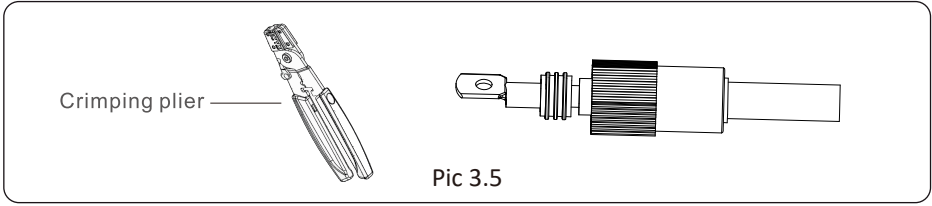

d) Fasten terminal with a bolt. (as shown in picture 3.6)

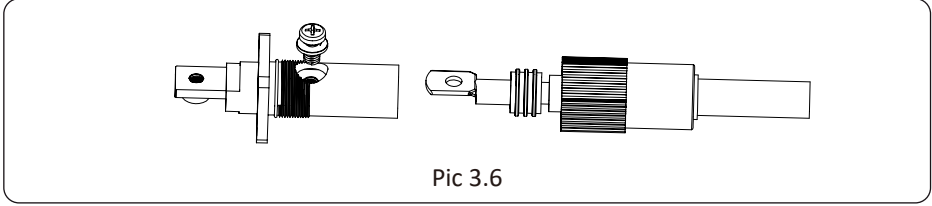

e) Fasten the terminal with outer cover. (as shown in picture 3.7)

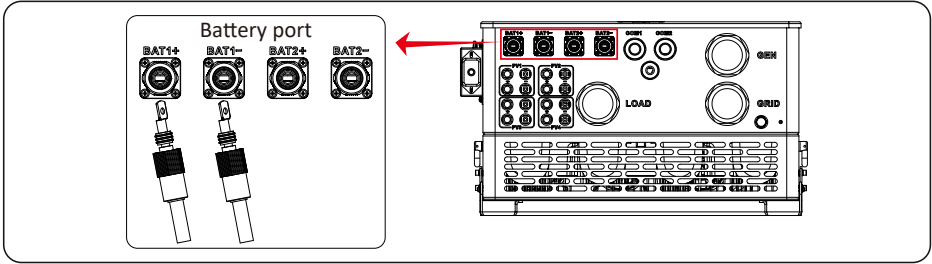
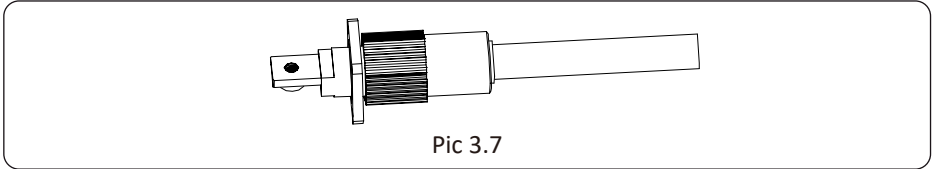

BMS connection

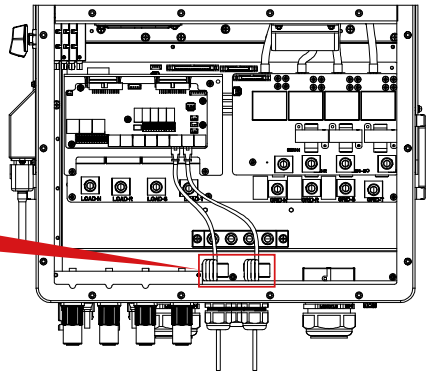
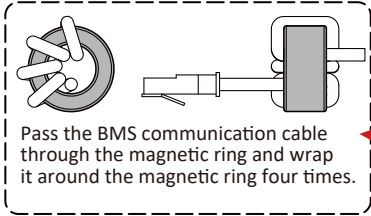

### 3.3.2 Function port definition

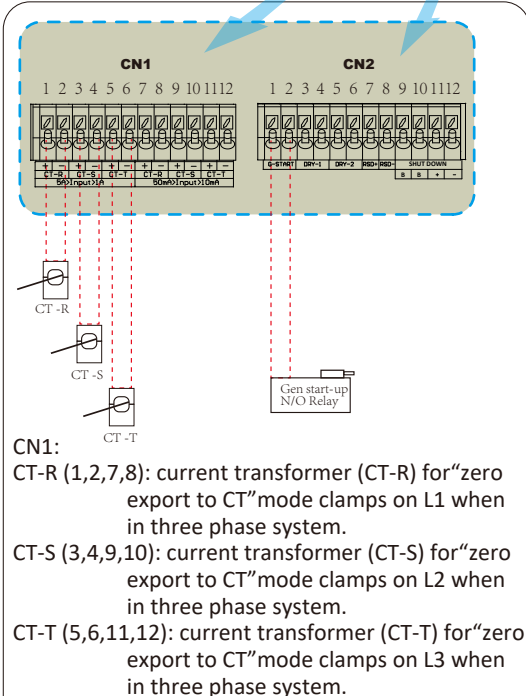
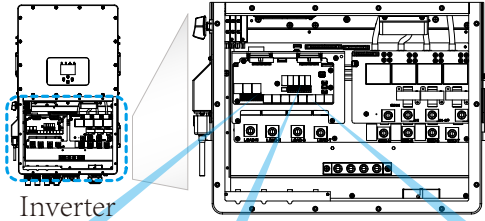

**CN1:**  
 CT-R (1,2,7,8): current transformer (CT-R) for “zero export to CT” mode clamps on L1 when in three phase system.  
 CT-S (3,4,9,10): current transformer (CT-S) for “zero export to CT” mode clamps on L2 when in three phase system.  
 CT-T (5,6,11,12): current transformer (CT-T) for “zero export to CT” mode clamps on L3 when in three phase system.

**CN2:**  
 G-start (1,2): dry contact signal for startup the diesel generator. When the "GEN signal" is active, the open contact (GS) will switch on (no voltage output).

DRY-1 (3,4): Dry contact output. When the inverter is in off-grid mode and the “signal island mode” is checked, the dry contact will switch on.  
 DRY-2 (5,6): reserved.

RSD+,RSD- (7,8): When battery is connected and the inverter is in "ON" status, it will provide 12Vdc.

SHUT DOWN (9,10,11,12): when the terminal “B” & “B” is short-circuited with additional wire connection, or there’s 12Vdc input at the terminal “+ & -”, then the 12Vdc of RSD+ & RSD- will disappear immediately, and the inverter will shutdown immediately.

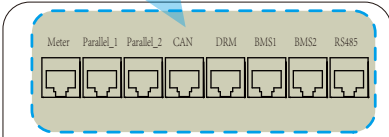

Meter: for energy meter communication.  
 Parallel\_1: Parallel communication port 1.  
 Parallel\_2: Parallel communication port 2 .  
 CAN: reserved.  
 DRM: Logic interface for AS/ NZS 4777.2:2020.  
 BMS1: BMS port for battery communication port 1.  
 BMS2: BMS port for battery communication port 2.  
 RS485: RS485 port.

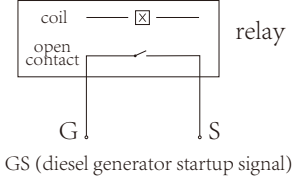

### 3.4 Grid connection and backup load connection

- Before connecting to the grid, a separate AC breaker must be installed between the inverter and the grid, and also between the backup load and the inverter. This will ensure the inverter can be securely disconnected during maintenance and fully protected from over current. For the 29.9/30/35/40/50kW model, the recommended AC breaker for backup load is 240A. For the 29.9/30/35/40/50kW model, the recommended AC breaker for grid is 240A. In final installation, breaker certified according to AS60947.3 shall be installed with the equipment.
- There are three terminal blocks with "Grid" "Load" and "GEN" markings. Please do not misconnect input and output connectors.



All wiring must be performed by a qualified personnel. It is very important for system safety and efficient operation to use appropriate cable for AC input connection. To reduce risk of injury, please use the proper recommended cable as below.

Grid connection and backup load connection (Copper wires) (bypass)

Model	Wire Size	Cable(mm <sup>2</sup> )	Torque value(max)
29.9/30/35/40/50kW	4/0AWG	107	28.2Nm

Grid connection and backup load connection (Copper wires)

Model	Wire Size	Cable(mm <sup>2</sup> )	Torque value(max)
29.9/30/35kW	6AWG	13.3	12.4Nm
40kW	4AWG	21.1	12.4Nm
50kW	2AWG	33.6	16.9Nm

Chart 3-3 Recommended Size for AC wires

#### Please follow below steps to implement Grid, load and Gen port connection:

1. Before making Grid, load and Gen port connection, be sure to turn off AC breaker or disconnecter first.
2. Remove insulation sleeve 10mm length, insert the wires according to polarities indicated on the terminal block. Make sure the connection is complete.

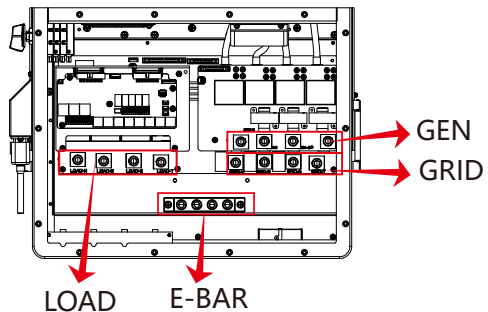
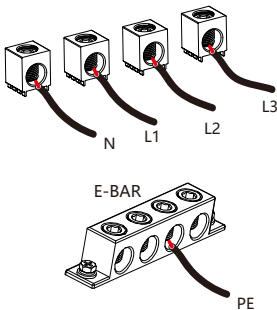



Be sure that AC power source is disconnected before attempting to wire it to the unit.

3. Then, insert AC output wires according to polarities indicated on the terminal block and tighten terminal. Be sure to connect corresponding N wires and PE wires to related terminals as well.
4. Make sure the wires are securely connected.
5. Appliances such as air conditioner are required at least 2-3 minutes to restart because it is required to have enough time to balance refrigerant gas inside of circuit. If a power shortage occurs and recovers in short time, it will cause damage to your connected appliances. To prevent this kind of damage, please check manufacturer of air conditioner if it is equipped with time-delay function before installation. Otherwise, this inverter will trigger overload fault and cut off output to protect your appliance but sometimes it still causes internal damage to the air conditioner

### 3.5 PV Connection

The PV modules used to connected to this inverter shall be Class A rating certified according to IEC 61730.

Before connecting to PV modules, please install a separately DC circuit breaker between inverter and PV modules. It is very important for system safety and efficient operation to use appropriate cable for PV module connection.



To avoid any malfunction, do not connect any PV modules with possible leakage current to the inverter. For example, grounded PV modules will cause leakage current to the inverter. When using PV modules, please ensure the PV+ & PV- of solar panel is not connected to the system ground bar.



It is requested to use PV junction box with surge protection. Otherwise, it will cause damage on inverter when lightning occurs on PV modules.

#### 3.5.1 PV Module Selection:

When selecting proper PV modules, please be sure to consider below parameters:

- 1) Open circuit Voltage (Voc) of PV modules can not exceed max. PV array open circuit voltage of inverter.
- 2) Open circuit Voltage (Voc) of PV modules should be higher than min. start voltage.

<i>Inverter Model</i>	<i>29.9kW</i>	<i>30kW</i>	<i>35kW</i>	<i>40kW</i>	<i>50kW</i>
PV Input Voltage	600V (180V~1000V)				
PV Array MPPT Voltage Range	150V-850V				
No. of MPP Trackers	3			4	
No. of Strings per MPP Tracker	2+2+2			2+2+2+2	

Chart 3-5

### 3.5.2 PV Module Wire Connection:

1. Switch the Grid Supply Main Switch(AC)OFF.
2. Switch the DC Isolator OFF.
3. Assemble PV input connector to the inverter.



**Safety Hint:**

When using PV modules, please ensure the PV+ & PV- of solar panel is not connected to the system ground bar.



**Safety Hint:**

Before connection, please make sure the polarity of PV array matches the “DC+” and “DC-” symbols.



**Safety Hint:**

Before connecting inverter, please make sure the PV array open circuit voltage is within the 1000V of the inverter.



**Note:**

This inverter complies with IEC 62109-2 clause 13.9 for earth fault alarm monitoring. If an Earth Fault Alarm occurs, the inverter will not connect to the grid and will report an error F04 on its LCD. At the same time, the buzzer will sound. For the machine installed with Wi-Fi/GPRS, the alarm information can be seen on the corresponding monitoring website, and can also be received by the APP on the mobile phone.

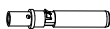

Pic 5.1 DC+ male connector

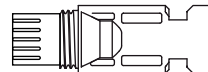

Pic 5.2 DC- female connector



**Safety Hint:**

Please use approved DC cable for PV system.

Cable type	Cross section (mm <sup>2</sup> )	
	Range	Recommended value
Industry generic PV cable (model: PV1-F)	2.5~4 (12~10AWG)	2.5(12AWG)

Chart 3-6

The steps to assemble the DC connectors are listed as follows:

- a) Strip off the DC wire about 7mm, disassemble the connector cap nut (see picture 5.3).

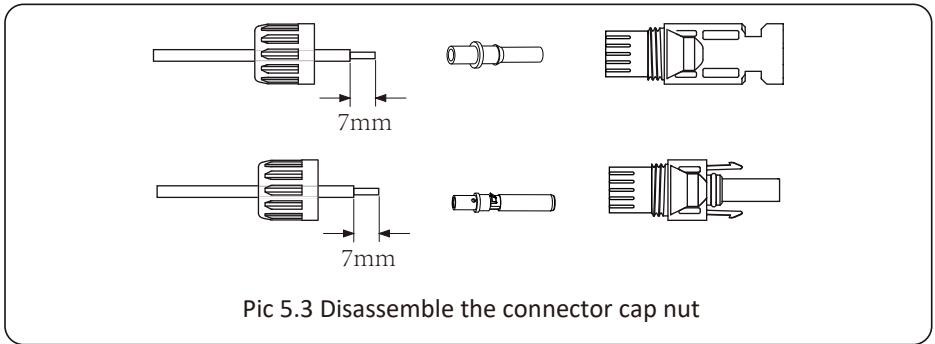

- b) Crimping metal terminals with crimping pliers as shown in picture 5.4.

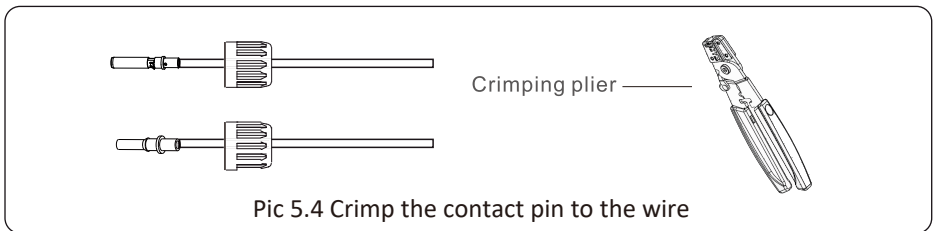

- c) Insert the contact pin to the top part of the connector and screw up the cap nut to the top part of the connector. (as shown in picture 5.5).

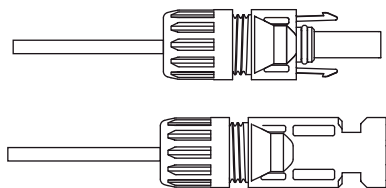

Pic 5.5 connector with cap nut screwed on

d) Finally insert the DC connector into the positive and negative input of the inverter, shown as picture 5.6

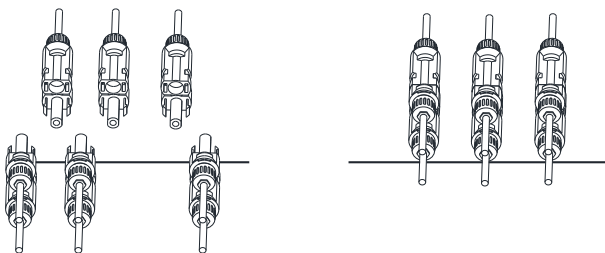

Pic 5.6 DC input connection



**Warning:**

Sunlight shines on the panel will generate voltage, high voltage in series may cause danger to life. Therefore, before connecting the DC input line, the solar panel needs to be blocked by the opaque material and the DC switch should be 'OFF', otherwise, the high voltage of the inverter may lead to life-threatening conditions. Please do not switch off DC isolator when the DC current when there is high voltage or current. Technicians need to wait until night to keep safety.



**Warning:**

Please use its own DC power connector from the inverter accessories. Do not interconnect the connectors of different manufacturers. Max. DC input current should be 20A. if exceeds, it may damage the inverter and it is not covered by Deye warranty.

### 3.6 CT Connection

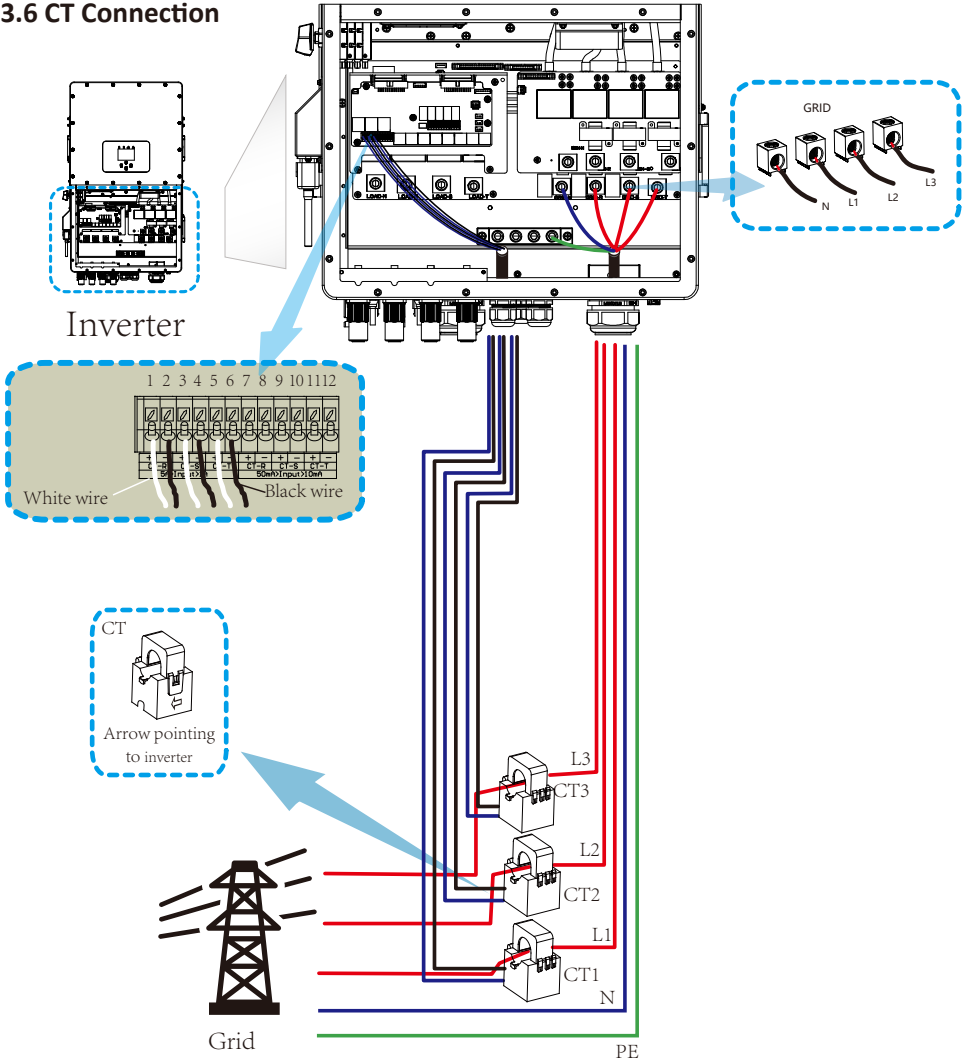

**\*Note:** when the reading of the load power on the LCD is not correct, please reverse the CT arrow.

### 3.6.1 Meter Connection

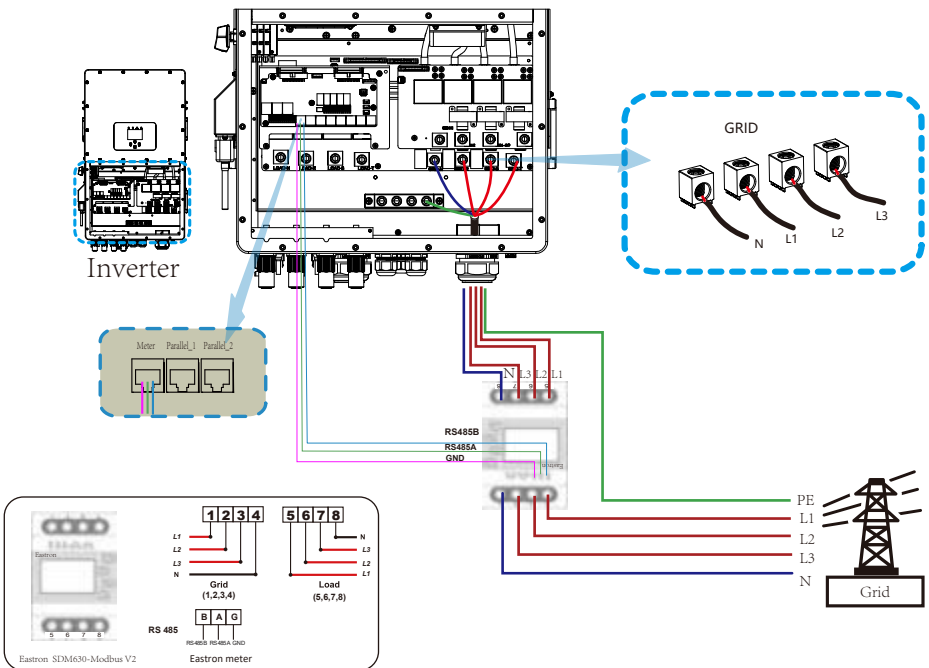
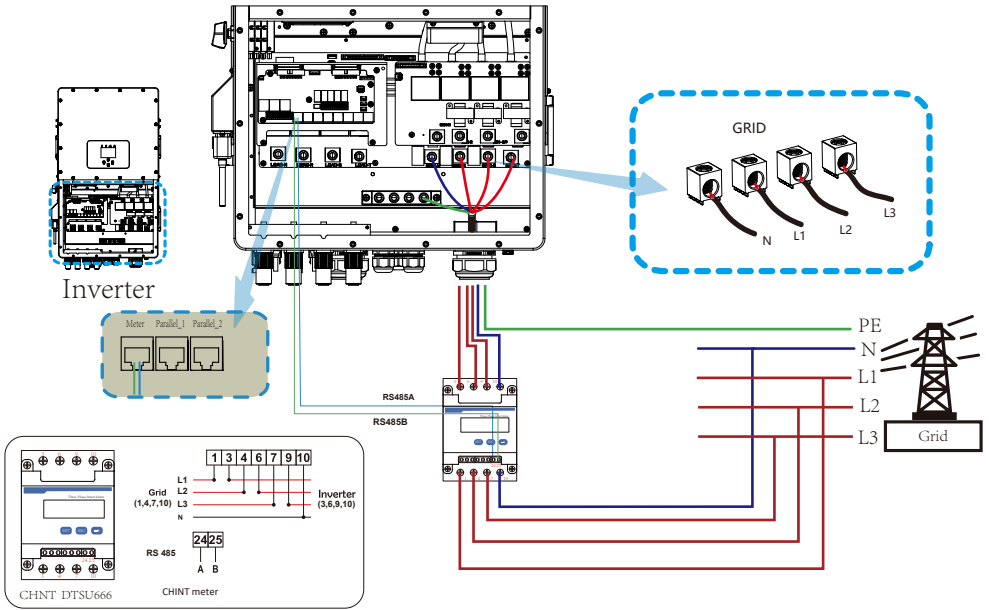

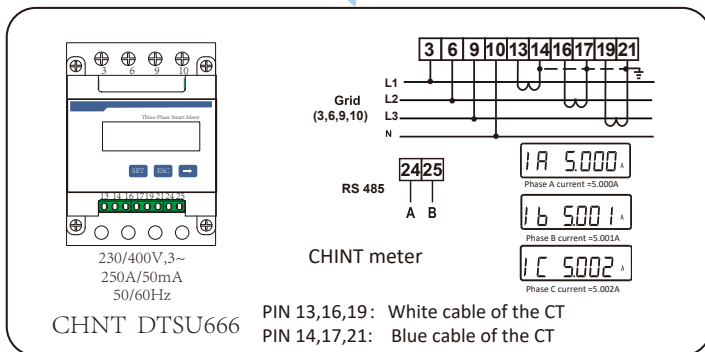
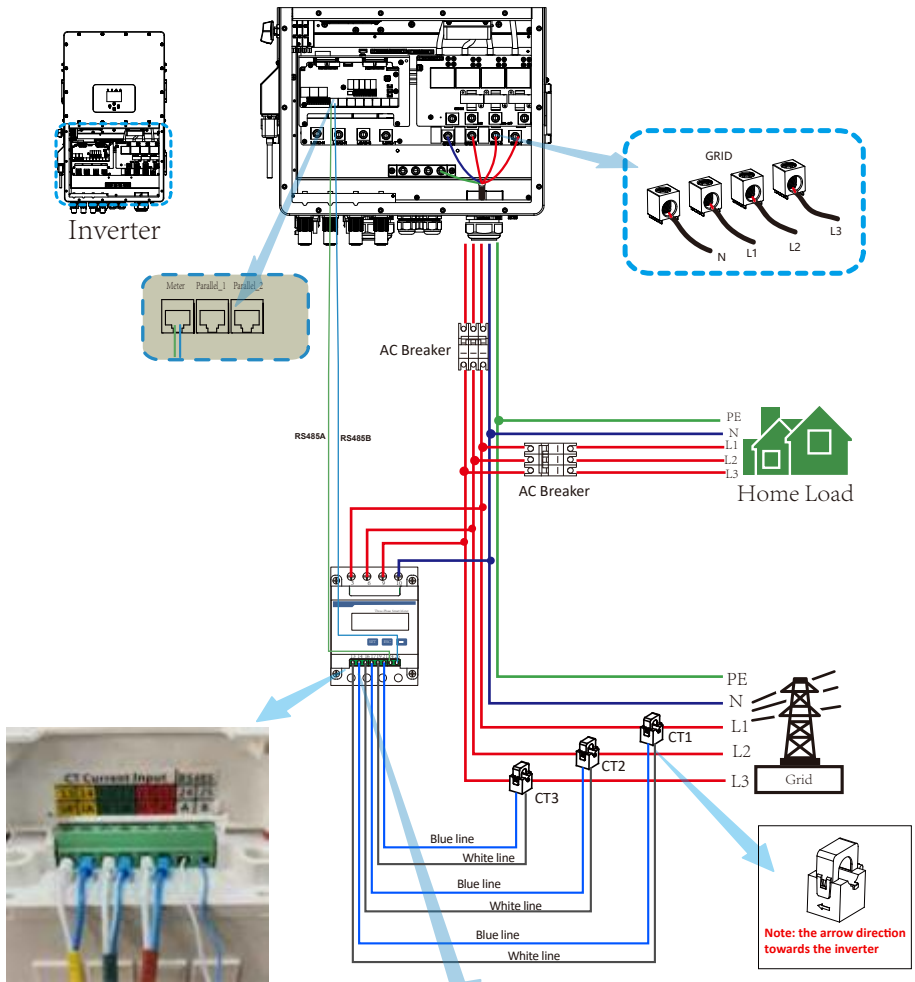

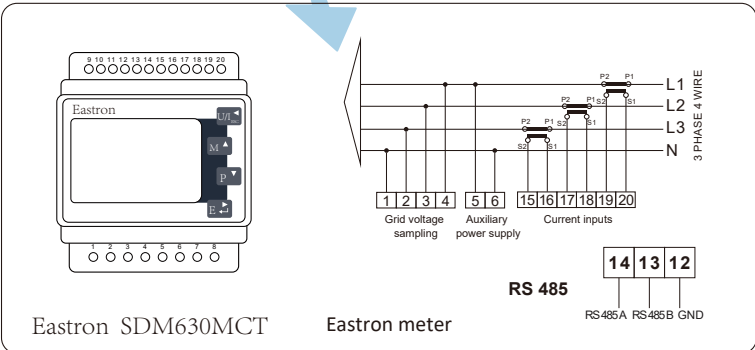
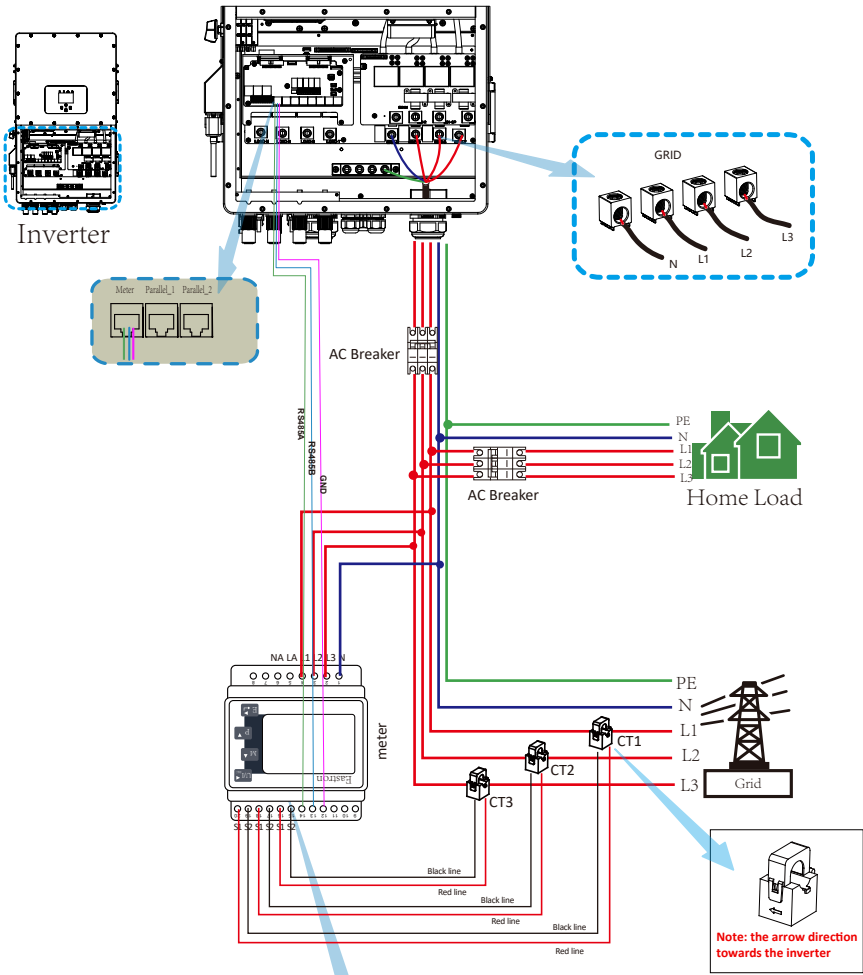



**Note:**

When the inverter is in the off-grid state, the N line needs to be connected to the earth.



**Note:**

inverter has built-in leakage current detection circuit, if an external RCD is required, a type-A RCD with rated residual current of 300mA or higher is suggested. Otherwise inverter may not work properly.

### 3.7 Earth Connection(mandatory)

Ground cable shall be connected to ground plate on grid side this prevents electric shock if the original protective conductor fails.

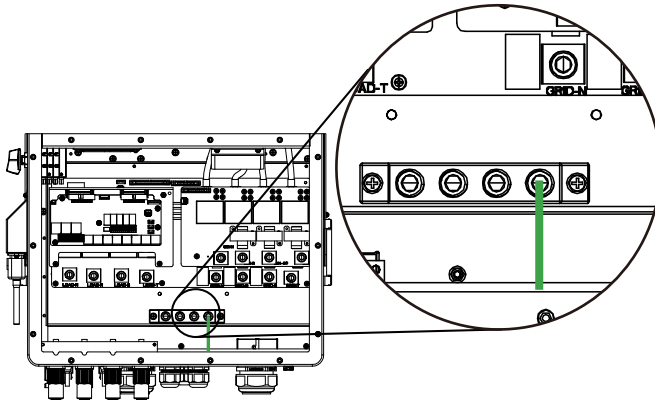

Earth connection(Copper wires)

Model	Wire Size	Cable(mm <sup>2</sup> )	Torque value(max)
29.9/30/35/40/50kW	0AWG	53.5	20.3Nm

The conductor should be made of the same metal as the phase conductors.

### 3.8 WIFI Connection

For the configuration of Wi-Fi Plug, please refer to illustrations of the Wi-Fi Plug. The Wi-Fi Plug is not a standard configuration, it's optional.

For WIFI configuration, please check the manual of "Wi-Fi-Plug configuration Manual".

Web monitoring address: <https://pro.solarmanpv.com>; (for Solarman distributor account)

<https://home.solarmanpv.com> (for Solarman end user account)

---

For mobile phone monitoring system, scan the QR code to download the APP.  
Also you can find it by searching “solarman business” in App store or Google Play store, and this App is for distributor/installer.  
Find it by searching “solarman smart” in App store or Google Play store and choose “solarman smart”, this app is for plant owner.



SOLARMAN Smart  
for end user



SOLARMAN Business  
for distributor/installer

### 3.9 Communication Connection

#### 1.BMS

Please connect the cable to BMS CAN port to realize BMS communication. Otherwise, BMS communication may fail. Please refer to Annex I for the interface pin definition of BMS RJ45 port.

#### 2.DRM (Only DRM0 is available)

In Australia and New Zealand, the inverter supports the demand response modes as specified in the standard AS/NZS 4777. Please refer to Annex I for the interface pin definition of DRM RJ45 port.

### 3.10 Wiring System for Inverter

This diagram is an example for an application that neutral connects with the PE in a distribution box.  
 For countries such as Australia, New Zealand, South Africa, etc., please follow local wiring regulations!

In final installation, breaker certified according to AS60947.3 shall be installed with the equipment. All circuit breakers are external components of the inverter.

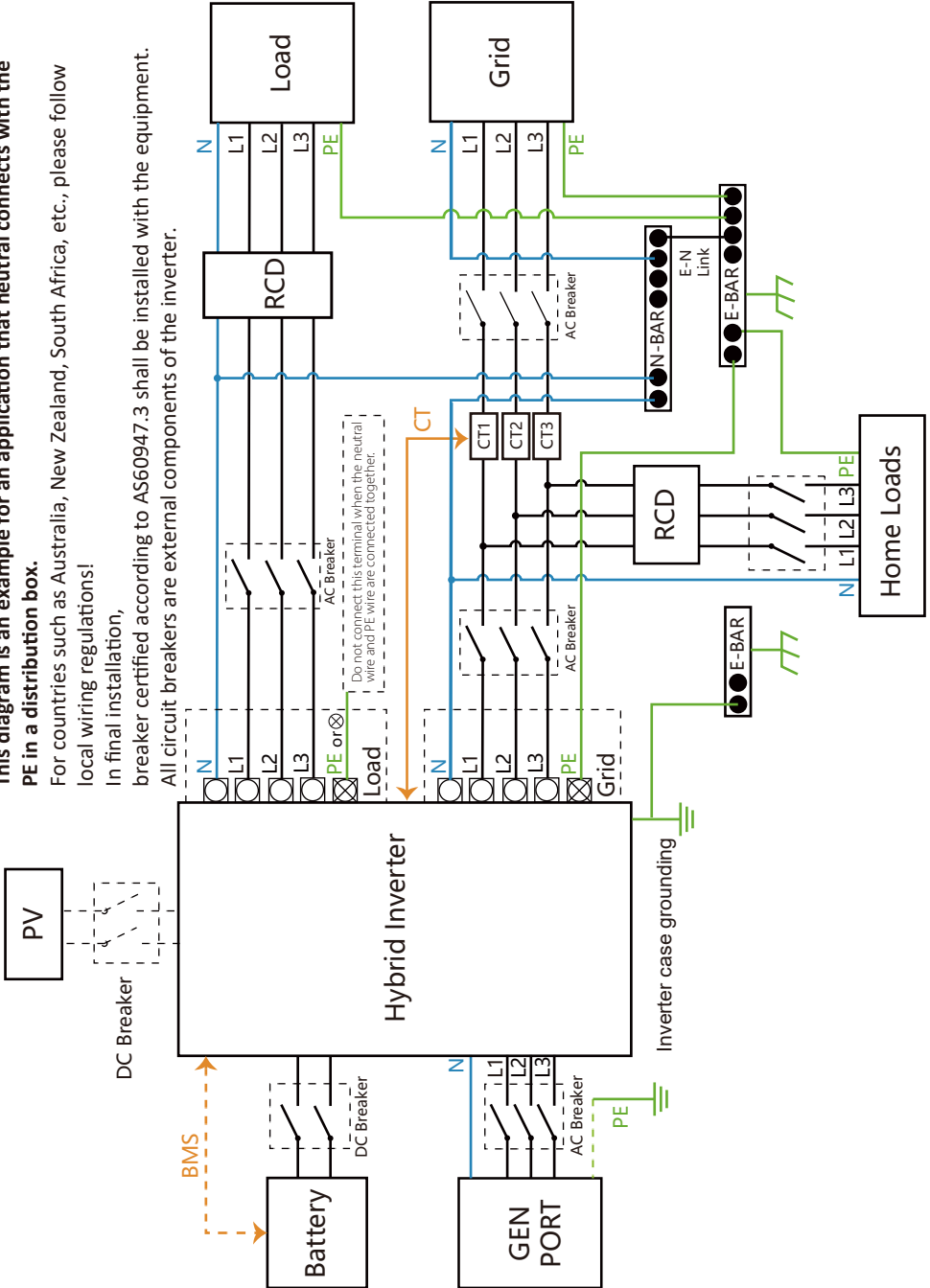

### 3.10 Wiring diagram

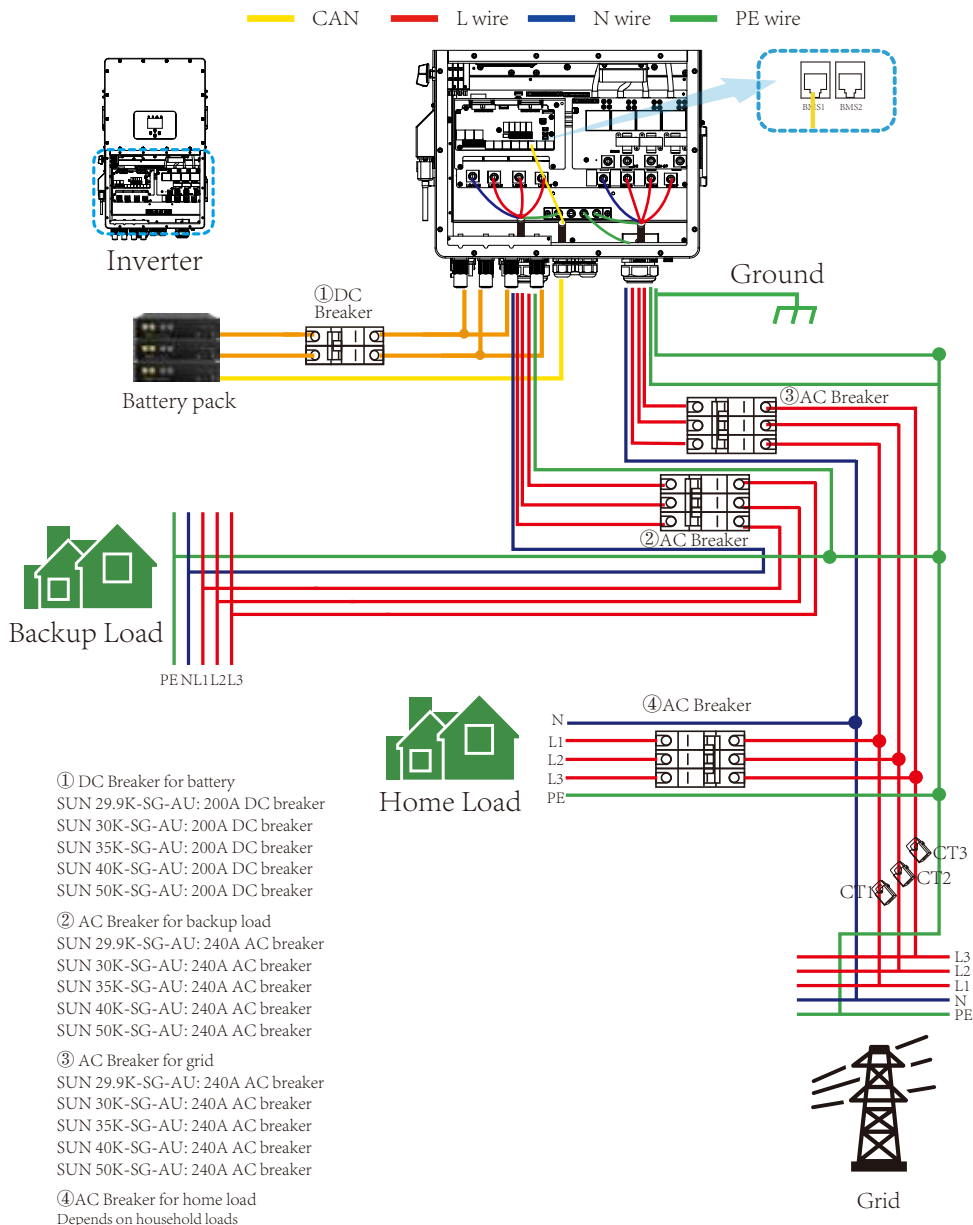

### 3.11 Typical application diagram of diesel generator

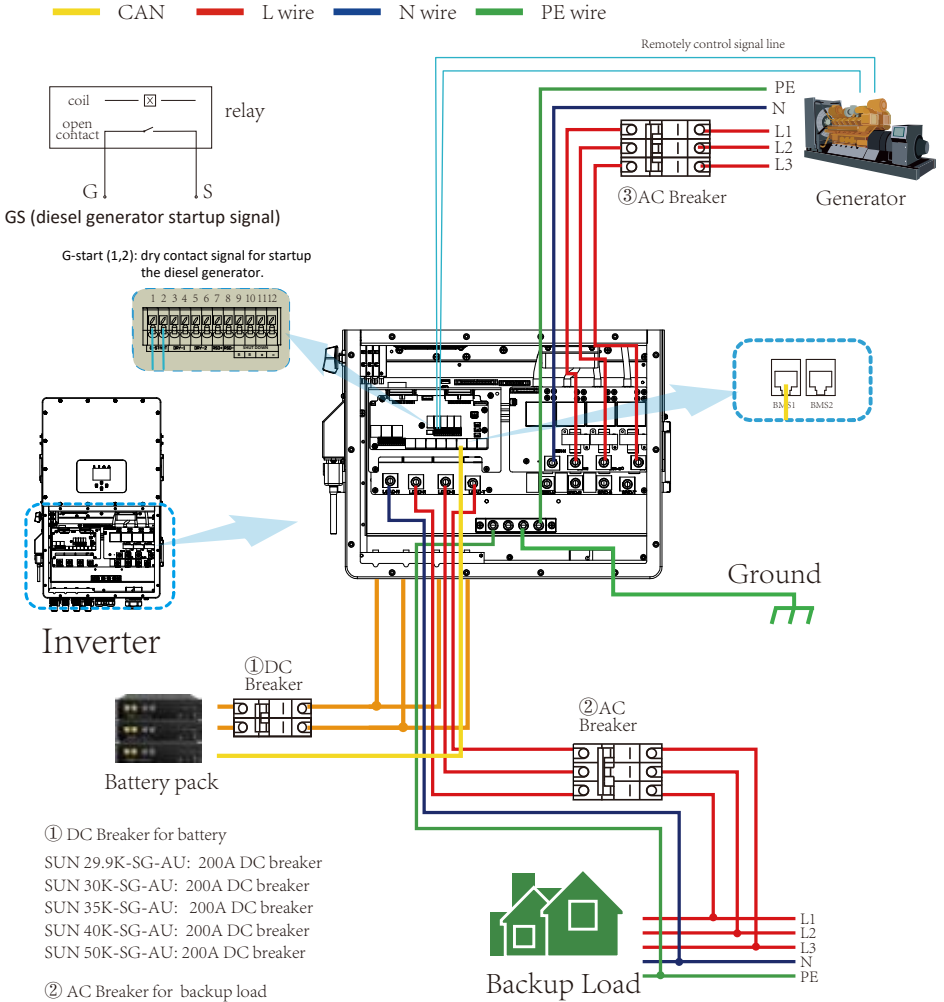

#### ① DC Breaker for battery

SUN 29.9K-SG-AU: 200A DC breaker  
 SUN 30K-SG-AU: 200A DC breaker  
 SUN 35K-SG-AU: 200A DC breaker  
 SUN 40K-SG-AU: 200A DC breaker  
 SUN 50K-SG-AU: 200A DC breaker

#### ② AC Breaker for backup load

SUN 29.9K-SG-AU: 240A AC breaker  
 SUN 30K-SG-AU: 240A AC breaker  
 SUN 35K-SG-AU: 240A AC breaker  
 SUN 40K-SG-AU: 240A AC breaker  
 SUN 50K-SG-AU: 240A AC breaker

#### ③ AC Breaker for Generator port

SUN 29.9K-SG-AU: 240A AC breaker  
 SUN 30K-SG-AU: 240A AC breaker  
 SUN 35K-SG-AU: 240A AC breaker  
 SUN 40K-SG-AU: 240A AC breaker  
 SUN 50K-SG-AU: 240A AC breaker

### 3.12 Three phase parallel connection diagram

Note: For the parallel system, the lead-acid battery is not supported. Please use Deye approved lithium battery.

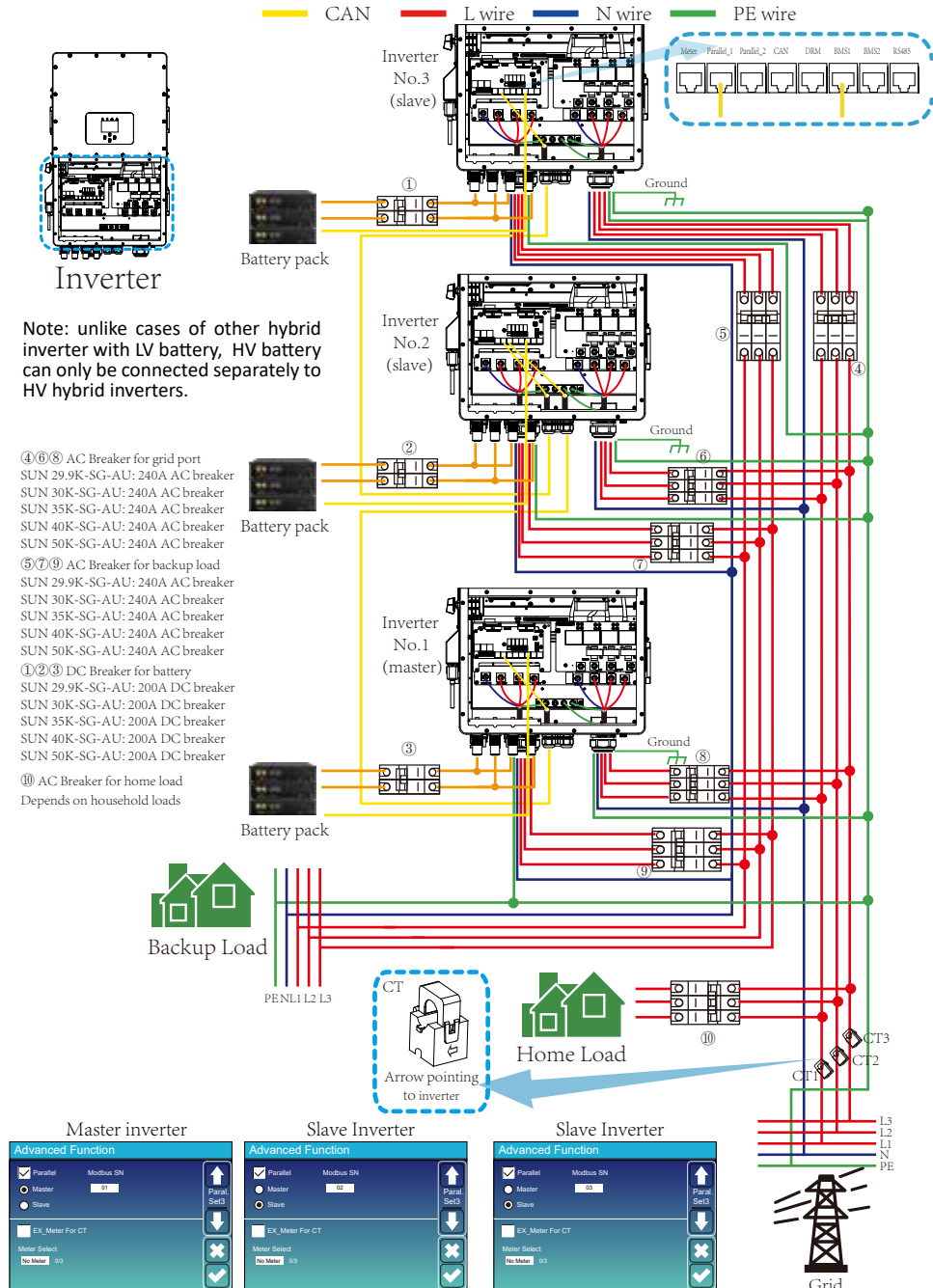

## 4. OPERATION

### 4.1 Power ON/OFF

Once the unit has been properly installed and the batteries are connected well, simply press On/Off button(located on the left side of the case) to turn on the unit. When system without battery connected, but connect with either PV or grid, and ON/OFF button is switched off, LCD will still light up(Display will show OFF), In this condition, when switch on ON/OFF button and select NO battery,system can still working.(NOTE: Choose the correct country code. (refer to section 5.8 of this manual) Notice: Different distribution network operators in different countries have different requirements regarding grid connections of PV grid connected inverters. Therefore, it's very important to make sure that you have selected the correct country code according to requirements of local authority. Please consult qualified electrical engineer or personnel from electrical safety authorities about this.)

### 4.2 Operation and Display Panel

The operation and display panel, shown in below chart, is on the front panel of the inverter. It includes four indicators, four function keys and a LCD display, indicating the operating status and input/output power information.

<i>LED Indicator</i>		<i>Messages</i>
DC	Green led solid light	PV Connection normal
AC	Green led solid light	Grid Connection normal
Normal	Green led solid light	Inverter operating normal
Alarm	Red led solid light	Malfunction or warning

Chart 4-1 LED indicators

<i>Function Key</i>	<i>Description</i>
Esc	To exit setting mode
Up	To go to previous selection
Down	To go to next selection
Enter	To confirm the selection

Chart 4-2 Function Buttons

## 5. LCD Display Icons

### 5.1 Main Screen

The LCD is touchscreen, below screen shows the overall information of the inverter.

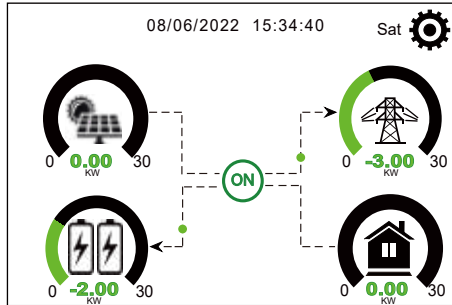

1.The icon in the center of the home screen indicates that the system is Normal operation. If it turns into "comm./F01~F64" , it means the inverter has communication errors or other errors, the error message will display under this icon(F01-F64 errors, detail error info can be viewed in the System Alarms menu).

2.At the top of the screen is the time.

3.System Setup Icon, Press this set button,you can enter into the system setup screen which including Basic Setup, Battery Setup, Grid Setup, System Work Mode, Generator port use, Advanced function and Li-Batt info.

4.The main screen showing the info including Solar, Grid, Load and Battery. Its also displaying the energy flow direction by arrow. When the power is approximate to high level, the color on the panels will changing from green to red so system info showing vividly on the main screen.

- PV power and Load power always keep positive.
- Grid power negative means sell to grid, positive means get from grid.
- Battery power negative means charge, positive means discharge.

### 5.1.1 LCD operation flow chart

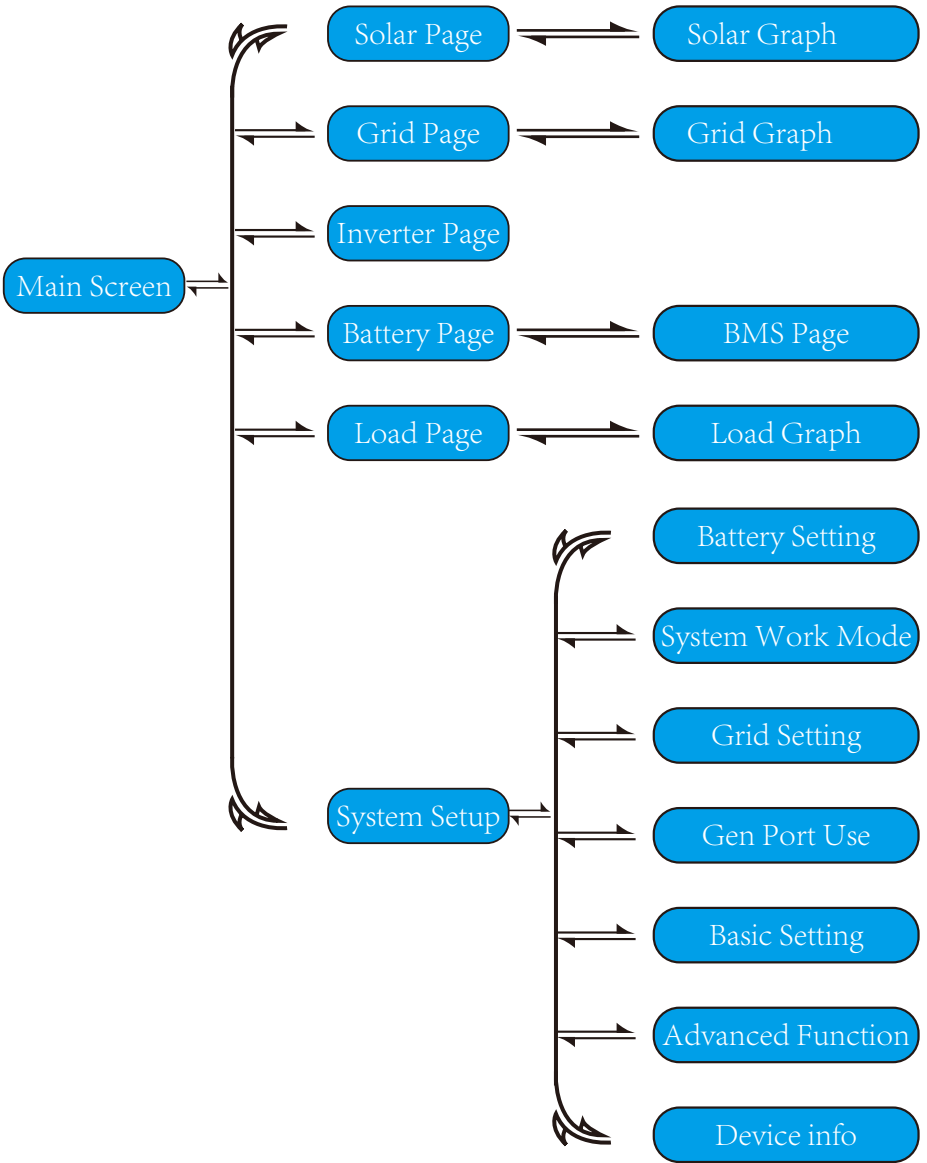

## 5.2 Solar Power Curve

**Solar**

PV1-V: 286V	PV1-I: 5.5A	PV1-P: 1559W
PV2-V: 286V	PV2-I: 5.5A	PV2-P: 1559W
PV3-V: 286V	PV3-I: 5.5A	PV3-P: 1559W
PV4-V: 286V	PV4-I: 5.5A	PV4-P: 1559W

Power: 1560W

Today=8.0 KWH

Total =12.00 KWH

Energy

This is Solar Panel detail page.

- ① Solar Panel Generation.
- ② Voltage, Current, Power for each MPPT.
- ③ Daily and total PV production.

Press the "Energy" button will enter into the power curve page.

1166w	1244w 50Hz	-81w 50Hz
L1N: 221v L2N: 229v L3N: 225v	0w 1166w 0w	L1N: 222v L2N: 230v L3N: 223v
<b>Load</b>		
21w		
0w 150V -0.41A 27.0C		
<b>Battery</b>		

0.8A	5.0A	0.9A
HM:	LD:	INV_P:
-10W	28W	-30W
5W	1192W	-26W
0W	24W	-25W
		AC_T:
		38.8C

	<b>Grid</b>	<b>Inverter</b>
0W	0W	0W
0V	0V	0V
0.0A	0.0A	0.0A

Energy

This is Inverter detail page.

- ① Inverter Generation.
- Voltage, Current, Power for each Phase.
- AC-T: mean Heat-sink temperature.

**Load**

Power: 55W

Today=0.5 KWH

Total =1.60 KWH

L1: 220V	P1: 19W
L2: 220V	P2: 18W
L3: 220V	P3: 18W

Energy

This is Load detail page.

- ① Load Power.
- ② Voltage, Power for each Phase.
- ③ Daily and total Load consumption .

When you check "Selling First" or "Zero export to Load" on system work mode page, the information on this page is about backup load which connect on Load port of hybrid inverter.

When you check "Zero export to CT" on system work mode page, the information on this page is including backup load and home load.

Press the "Energy" button will enter into the power curve page.

**Grid**

Stand by  
0W  
0.0Hz

BUY  
Today=2.2KWH  
Total =11.60 KWH

SELL  
Today=0.0KWH  
Total =8.60 KWH

CT1: 0W	LD1: 0W
CT2: 0W	LD2: 0W
CT3: 0W	LD3: 0W

L1: 0V L2: 0V L3: 0V

Energy

This is Grid detail page.

- ① Status, Power, Frequency.
- ② L: Voltage for each Phase  
CT: Power detected by the external current sensors  
LD: Power detected using internal sensors on AC grid in/out breaker
- ③ BUY: Energy from Grid to Inverter,  
SELL: Energy from Inverter to grid.

Press the "Energy" button will enter into the power curve page.

## Batt

Battery 1  
Stand by

U:170V

I:2.04A

Power: 101W

Temp:25.0C

Energy

This is Battery detail page.

if you use Lithium Battery, you can enter BMS page.

## Li-BMS

Mean Voltage:170.0V    Charging Voltage :180.0V  
 Total Current:37.00A    Discharging Voltage :160.0V  
 Mean Temp :23.5C    Charging current :30A  
 Total SOC :38%    Discharging current :25A  
 Dump Energy:57Ah

Sum  
Data

Details  
Data

## Li-BMS

	Volt	Curr	Temp	SOC	Energy	Charge	Fault	
						Volt	Curr	
1	150.3V	18.70A	30.8C	52.0%	26.0Ah	0.0V	0.0A	0100
2	150.2V	18.10A	31.0C	51.0%	25.5Ah	153.2V	25.0A	0100
3	150.1V	16.90A	30.2C	12.0%	6.0Ah	153.2V	25.0A	0100
4	0.00V	0.00A	0.0C	0.0%	0.0Ah	0.0V	0.0A	0100
5	0.00V	0.00A	0.0C	0.0%	0.0Ah	0.0V	0.0A	0100
6	0.00V	0.00A	0.0C	0.0%	0.0Ah	0.0V	0.0A	0100
7	0.00V	0.00A	0.0C	0.0%	0.0Ah	0.0V	0.0A	0100
8	0.00V	0.00A	0.0C	0.0%	0.0Ah	0.0V	0.0A	0100
9	0.00V	0.00A	0.0C	0.0%	0.0Ah	0.0V	0.0A	0100
10	0.00V	0.00A	0.0C	0.0%	0.0Ah	0.0V	0.0A	0100
11	0.00V	0.00A	0.0C	0.0%	0.0Ah	0.0V	0.0A	0100
12	0.00V	0.00A	0.0C	0.0%	0.0Ah	0.0V	0.0A	0100
13	0.00V	0.00A	0.0C	0.0%	0.0Ah	0.0V	0.0A	0100
14	0.00V	0.00A	0.0C	0.0%	0.0Ah	0.0V	0.0A	0100
15	0.00V	0.00A	0.0C	0.0%	0.0Ah	0.0V	0.0A	0100

Sum  
Data

Details  
Data

## 5.3 Curve Page-Solar & Load & Grid

### Solar Power Production:Day

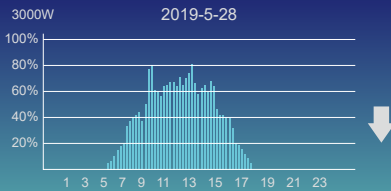

CANCEL Day Month Year Total

### System Solar Power:Month

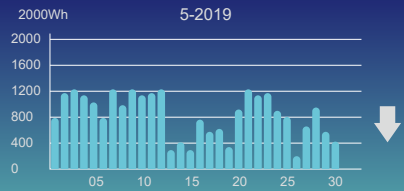

CANCEL Day Month Year Total

### System Solar Power:Year

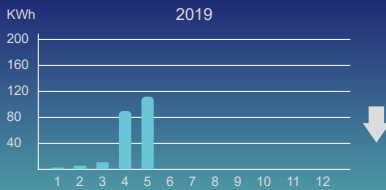

CANCEL Day Month Year Total

### System Solar Power:Total

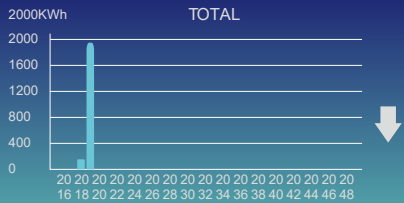

CANCEL Day Month Year Total

Solar power curve for daily, monthly, yearly and total can be roughly checked on the LCD, for more accuracy power generation, pls check on the monitoring system. Click the up and down arrow to check power curve of different period.

## 5.4 System Setup Menu

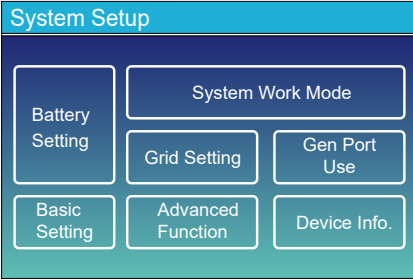

This is System Setup page.

## 5.5 Basic Setup Menu

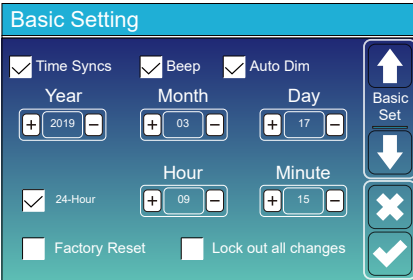

**Factory Reset:** Reset all parameters of the inverter.  
**Lock out all changes:** Enable this menu for setting parameters that require locking and cannot be set up. Before performing a successful factory reset and locking the systems, to keep all changes you need to type in a password to enable the setting.

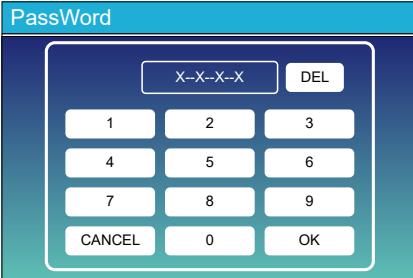

System selfchek: After ticking this item, it needs input the password.

## 5.6 Battery Setup Menu

Battery Setting

**Batt Mode**

Lithium      Batt Capacity    0Ah  
 Use Batt V      Max A Charge    0A  
 No Batt          Max A Discharge 0A

Parallel bat1&bat2

↑  
Batt Mode  
↓  
✕  
✓

**Battery capacity:** it shows your battery bank size to Deye hybrid inverter.

**Use Batt V:** Use Battery Voltage for all the settings (V).

**Max. A charge/discharge:** Max battery charge/discharge current(0-50A for 29.9/30/35/40/50kW model).

For AGM and Flooded, we recommend Ah battery size x 20%= Charge/Discharge amps.

. For Lithium, we recommend Ah battery size x 50% = Charge/Discharge amps.

. For Gel, follow manufacturer' s instructions.

**No Batt:** tick this item if no battery is connected to the system.

**Parallel bat1&bat2:** if one set of battery was connected Bat 1 and Bat 2 then please enable this function.

Battery Setting

Start      30%      30%

A          50A      50A

Gen Charge       Grid Charge ②  
 Gen Signal       Grid Signal

Gen Max Run Time    24.0 hours ③

Gen Down Time      0.0 hours

↑  
Batt Set2  
↓  
✕  
✓

**This is Battery Setup page.** ① ③

**Start =30%:** Percent SOC below 30% system will AutoStart a connected generator to charge the battery bank.

**A = 50A:** Charge rate of 50A from the attached generator in Amps.

**Gen Charge:** uses the gen input of the system to charge battery bank from an attached generator.

**Gen Signal:** Normally open relay that closes when the Gen Start signal state is active.

**Gen Max Run Time:** It indicates the longest time Generator can run in one day, when time is up, the Generator will be turned off. 24H means that it does not shut down all the time.

**Gen Down Time:** It indicates the delay time of the Generator to shut down after it has reached the running time.

**This is Grid Charge, you need select.** ②

**Start =30%:** No use, Just for customization.

**A = 50A:** It indicates the Current that the Grid charges the Battery.

**Grid Charge:** It indicates that the grid charges the battery.

**Grid Signal:** Disable.

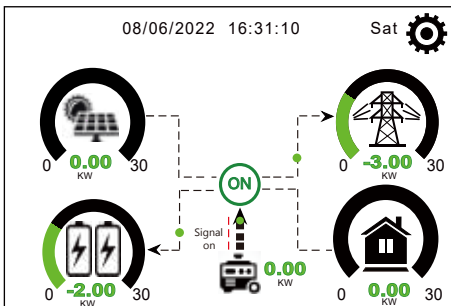

This page tells the PV and diesel generator power the load and battery.

**Generator**

Power: 6000W      Today=10 KWH  
    Total =10 KWH

V\_L1: 230V      P\_L1: 2KW  
 V\_L2: 230V      P\_L2: 2KW  
 V\_L3: 230V      P\_L3: 2KW

This page tells generator output voltage, frequency, power. And, how much energy is used from generator.

**Battery Setting**

Lithium Mode   

Shutdown       

Low Batt        

Restart         

↑  
Batt  
Set3  
↓  
✕  
✓

**Lithium Mode:** This is BMS protocol. Please reference the document (Approved Battery).

**Shutdown 10%:** It indicates the inverter will shutdown if the SOC below this value.

**Low Batt 20%:** It indicates the inverter will alarm if the SOC below this value.

**Restart 40%:** Battery SOC at 40% AC output will resume.

Recommended battery settings

Battery Type	Absorption Stage	Float Stage	Torque value (every 30 days 3hr)
Lithium	Follow its BMS voltage parameters		

5.7 System Work Mode Setup Menu

**System Work Mode**

Selling First     Max Solar Power

Zero Export To Load     Solar Sell

Zero Export To CT     Solar Sell

Max Sell Power     Zero-export Power

Energy pattern     BattFirst     LoadFirst

Grid Peak Shaving     Power

↑  
Work  
Mode1  
↓  
✕  
✓

**Work Mode**

**Selling First (Generation limit control):** This Mode allows hybrid inverter to sell back any excess power produced by the solar panels to the grid. If time of use is active, the battery energy also can be sold into grid. The PV energy will be used to power the load and charge the battery and then excess energy will flow to grid. Power source priority for the load is as follows:

1. Solar Panels.
2. Grid.
3. Batteries (until programable % discharge is reached).

**Zero Export To Load:** Hybrid inverter will only provide power to the backup load connected. The hybrid inverter will neither provide power to the home load nor sell power to grid. The built-in CT will detect power flowing back to the grid and will reduce the power of the inverter only to supply the local load and charge the battery.

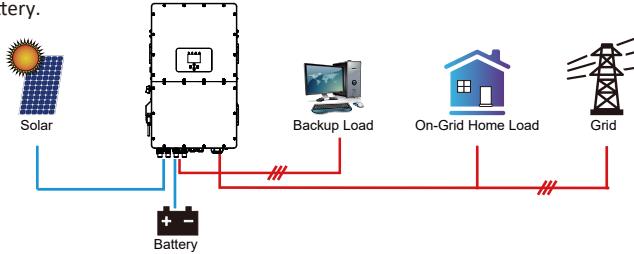

**Zero Export To CT(Export limit control):** Hybrid inverter will not only provide power to the backup load connected but also give power to the home load connected. If PV power and battery power is insufficient, it will take grid energy as supplement. The hybrid inverter will not sell power to grid. In this mode, a CT is needed. The installation method of the CT please refer to chapter 3.6 CT Connection. The external CT will detect power flowing back to the grid and will reduce the power of the inverter only to supply the local load, charge battery and home load.

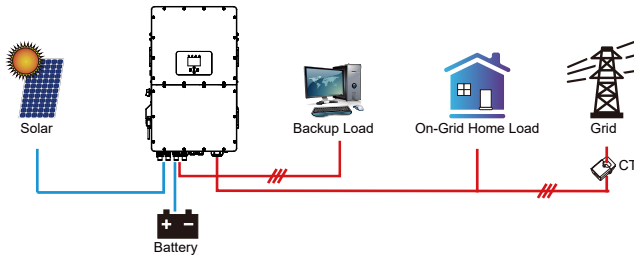

Selling First is Generation limit control function, which limits the amount of power generated by the inverter. In this state Max. sell power is the soft limit of the maximum apparent power that the inverter can generate, and Zero-export Power is the hard limit of the maximum apparent power that the inverter can generate.

Zero Export To CT is Export limit control function, it can limit the inverter export to grid active power. max. sell power is soft limit inverter export to grid max. active power, Zero-export Power is hard limit inverter export to grid.



**Note:**

Customer can only use export limit control function by CT or meter.

**Solar Sell:** "Solar sell" is for Zero export to load or Zero export to CT: when this item is active, the surplus energy can be sold back to grid. When it is active, PV Power source priority usage is as follows: load consumption and charge battery and feed into grid.

**Max. sell power:** Max sell power limits means Soft export. Allowed the maximum output power to flow to grid.

**Zero-export Power:** for zero-export mode, it tells the grid output power. Recommend to set it as 20-100W to ensure the hybrid inverter won't feed power to grid. Zero-export Power means Hard export, if you exceed the excess power output to the grid that you set, the inverter will stop immediately.

**Energy Pattern:** PV Power source priority.

**Batt First:** PV power is firstly used to charge the battery and then used to power the load. If PV power is insufficient, grid will make supplement for battery and load simultaneously.

**Load First:** PV power is firstly used to power the load and then used to charge the battery. If PV power is insufficient, Grid will provide power to load.

**Max Solar Power:** allowed the maximum DC input power.

**Grid Peak-shaving:** when it is active, grid output power will be limited within the set value. If the load power exceeds the allowed value, it will take PV energy and battery as supplement. If still can't meet the load requirement, grid power will increase to meet the load needs.

### System Work Mode

Grid Charge	Gen	Time Of Use		Power	Batt
		Time	Power		
<input type="checkbox"/>	<input type="checkbox"/>	01:00	5:00	32000	160V
<input type="checkbox"/>	<input type="checkbox"/>	05:00	9:00	32000	160V
<input checked="" type="checkbox"/>	<input type="checkbox"/>	09:00	13:00	32000	160V
<input checked="" type="checkbox"/>	<input type="checkbox"/>	13:00	17:00	32000	160V
<input checked="" type="checkbox"/>	<input type="checkbox"/>	17:00	21:00	32000	160V
<input checked="" type="checkbox"/>	<input type="checkbox"/>	21:00	01:00	32000	160V

Work Mode2

**Time of use:** it is used to program when to use grid or generator to charge the battery, and when to discharge the battery to power the load. Only tick "Time Of Use" then the follow items (Grid, charge, time, power etc.) will take effect.

**Note:** when in selling first mode and click time of use, the battery power can be sold into grid.

**Gen charge:** utilize diesel generator to charge the battery in a time period.

**Time:** real time, range of 01:00-24:00.

**Note:** when the grid is present, only the "time of use" is ticked, then the battery will discharge. Otherwise, the battery won't discharge even the battery SOC is full. But in the off-grid mode (when grid is not available, inverter will work in the off-grid mode automatically).

**Power:** Max. discharge power of battery allowed.

**Batt(V or SOC %):** battery SOC % or voltage at when the action is to happen.

**For example**

**During 01:00-05:00,**

if battery SOC is lower than 80%, it will use grid to charge the battery until battery SOC reaches 80%.

**During 05:00-08:00,**

if battery SOC is higher than 40%, hybrid inverter will discharge the battery until the SOC reaches 40%. At the same time, if battery SOC is lower than 40%, then grid will charge the battery SOC to 40%.

**During 08:00-10:00,**

if battery SOC is higher than 40%, hybrid inverter will discharge the battery until the SOC reaches 40%.

**During 10:00-15:00,**

when battery SOC is higher than 80%, hybrid inverter will discharge the battery until the SOC reaches 80%.

**During 15:00-18:00,**

when battery SOC is higher than 40%, hybrid inverter will discharge the battery until the SOC reaches 40%.

**During 18:00-01:00,**

when battery SOC is higher than 35%, hybrid inverter will discharge the battery until the SOC reaches 35%.

### Battery Setting

Start

A

Gen Charge  Grid Charge ③

Gen Signal  Grid Signal

Gen Max Run Time

Gen Down Time

Batt Set2

### System Work Mode

Grid Charge	Gen	Time Of Use		Power	Batt
		Time	Power		
<input checked="" type="checkbox"/>	<input type="checkbox"/>	01:00	5:00	32000	80%
<input checked="" type="checkbox"/>	<input type="checkbox"/>	05:00	8:00	32000	40%
<input type="checkbox"/>	<input type="checkbox"/>	08:00	10:00	32000	40%
<input checked="" type="checkbox"/>	<input type="checkbox"/>	10:00	15:00	32000	80%
<input type="checkbox"/>	<input type="checkbox"/>	15:00	18:00	32000	40%
<input type="checkbox"/>	<input type="checkbox"/>	18:00	01:00	32000	35%

Work Mode2

### System Work Mode

Mon	Tue	Wed	Thu	Fri	Sat	Sun
<input checked="" type="checkbox"/>	<input checked="" type="checkbox"/>	<input checked="" type="checkbox"/>	<input checked="" type="checkbox"/>	<input checked="" type="checkbox"/>	<input checked="" type="checkbox"/>	<input type="checkbox"/>

Work Mode4

It allows users to choose which day to execute the setting of "Time of Use".

For example, the inverter will execute the time of use page on Mon/Tue/Wed/Thu/Fri/Sat only.

## 5.8 Grid Setup Menu

### 5.8.1 Commissioning Procedure

If all physical connection is checked ok, please follow the steps below.

1. Turn on AC circuit breaker.
2. Turn on DC circuit breaker on PV strings and battery.
3. Turn on circuit breaker on battery pack.
4. Turn on DC switch on the inverter
5. Check the inverter status by inverter indicators and battery status by battery indicators.

## 5.8.2 Grid Standard Selection

**Grid Setting/Grid code selection**

Grid Mode:  0/23

Grid Frequency:  50HZ  60HZ

Phase Type:  0/120/240  0/240/120

Grid Level:

IT system-neutral is not grounded

Grid Set1

⌵

✕

✓

### Grid Mode:

General Standard、UL1741 & IEEE1547、CPUC RULE21、SRD-UL-1741、CEI\_0\_21\_Internal、EN50549\_CZ-PPDS(>16A)、Australia\_A、Australia\_B、Australia\_C、AS4777\_NewZealand、VDE4105、OVE-Directive R25、EN50549\_CZ\_PPDS\_L16A、NRS097、G98、G99、EN50549\_1\_Norway\_133V、EN50549\_1\_Norway\_230V、Japan\_200VAC\_3P3W、CEI\_0\_21\_External、CEI\_0\_21\_Areti、Japan\_400VAC\_3P3W、Japan\_415VAC\_3P4W、EN50549\_1\_Switzerland.

Please follow the local grid code and then choose the corresponding grid standard.

**Grid level:** there're several voltage levels for the inverter output voltage when it is in off-grid mode.  
LN:220V/LL:380V(AC), LN:230V/LL:400V(AC).

**IT system:** If the grid system is IT system, then please enable this option. For example, the IT grid system voltage is 230Vac (the Line voltage between any two live lines in a three-phase circuit is 230Vac, and the diagram is as follow) then please enable "IT system" and tick the "Grid level" as LN:230V/LL:400V(AC) as below picture shows.

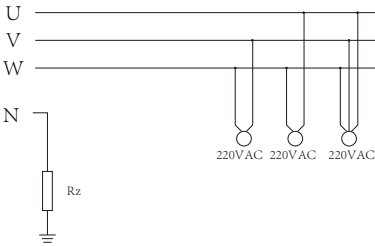

Rz: Large resistance ground resistor. Or the system doesn't have Neutral line

For The Australian Market:

For compliance with AS/NZS 4777.2:2020 please select from  
• Australia A • Australia B • Australia C • New Zealand

Please contact your local grid operator for which option to select

Note: By selecting Australia A, Australia B or Australia C the power quality response mode and grid protection settings will be reset to their default values for Australia RegionA, B, C respectively.

**Grid Setting/Grid code selection**

Grid Mode:  0/23

Grid Frequency:  50HZ  60HZ

Phase Type:  0/120/240  0/240/120

Grid Level:

IT system-neutral is not grounded

Grid Set1

⌵

✕

✓

Default volt-watt settings for different regions are shown in the following table:

Region	Default value	Vw <sub>1</sub>	Vw <sub>1</sub> -ch	Vw <sub>2</sub>	Vw <sub>2</sub> -ch
Australia A	Voltage	253V	207V	260V	215V
	Inverter maximum active power output level(P) % of S <sub>rated</sub>	100%	20%	20%	100%
Australia B	Voltage	250V	195V	260V	215V
	Inverter maximum active power output level(P) % of S <sub>rated</sub>	100%	0%	20%	100%
Australia C	Voltage	253V	207V	260V	215V
	Inverter maximum active power output level(P) % of S <sub>rated</sub>	100%	20%	20%	100%
New Zealand	Voltage	242V	216V	250V	224V
	Inverter maximum active power output level(P) % of S <sub>rated</sub>	100%	20%	20%	100%

Default volt-var settings for different regions are shown in the following table:

Region	Default value	Vv <sub>1</sub>	Vv <sub>2</sub>	Vv <sub>3</sub>	Vv <sub>4</sub>
Australia A	Voltage	207V	220V	240V	258V
	Inverter maximum active power output level(P) % of S <sub>rated</sub>	44%supplying	0%	0%	60%absorbing
Australia B	Voltage	205V	220V	235V	255V
	Inverter maximum active power output level(P) % of S <sub>rated</sub>	30%supplying	0%	0%	40%supplying
Australia C	Voltage	215V	230V	240V	255V
	Inverter maximum active power output level(P) % of S <sub>rated</sub>	44%supplying	0%	0%	60%supplying
New Zealand	Voltage	207V	220V	235V	244V
	Inverter maximum active power output level(P) % of S <sub>rated</sub>	60%supplying	0%	0%	60%supplying

### Grid Setting/Connect

Normal connect Normal Ramp rate 10s

Low frequency 48.00Hz High frequency 51.50Hz

Low voltage 185.0V High voltage 265.0V

Reconnect after trip Reconnect Ramp rate 36s

Low frequency 48.20Hz High frequency 51.30Hz

Low voltage 187.0V High voltage 263.0V

Reconnection Time 60s PF 1.000

Grid Set2

**Normal connect:** The allowed grid voltage/frequency range when the inverter first time connect to the grid.

**Normal Ramp rate:** It is the startup power ramp.

**Reconnect after trip:** The allowed grid voltage /frequency range for the inverter connects the grid after the inverter trip from the grid.

**Reconnect Ramp rate:**It is the reconnection power ramp.

**Reconnection time:** The waiting time period for the inverter connects the grid again.

**PF:** Power factor which is used to adjust inverter reactive power.

### Grid Setting/IP Protection

Over voltage U>(10 min. running mean) 260.0V

HV3 265.0V HF3 51.50Hz

HV2 265.0V 0.10s HF2 51.50Hz 0.10s

HV1 265.0V 0.10s HF1 51.50Hz 0.10s

LV1 185.0V 0.10s LF1 48.00Hz 0.10s

LV2 185.0V 0.10s LF2 48.00Hz 0.10s

LV3 185.0V LF3 48.00Hz

Grid Set3

**HV1:** Level 1 overvoltage protection point;  
**HV2:** Level 2 overvoltage protection point; ② 0.10s—Trip time.  
**HV3:** Level 3 overvoltage protection point.

**LV1:** Level 1 undervoltage protection point;  
**LV2:** Level 2 undervoltage protection point;  
**LV3:** Level 3 undervoltage protection point.

**HF1:** Level 1 over frequency protection point;  
**HF2:** Level 2 over frequency protection point;  
**HF3:** Level 3 over frequency protection point.

**LF1:** Level 1 under frequency protection point;  
**LF2:** Level 2 under frequency protection point;  
**LF3:** Level 3 under frequency protection point.

### Grid Setting/F(W)

Over frequency Droop F 40%PE/Hz

Start freq F 50.20Hz Stop freq F 51.5Hz

Start delay F 0.00s Stop delay F 0.00s

Under frequency Droop F 40%PE/Hz

Start freq F 49.80Hz Stop freq F 49.80Hz

Start delay F 0.00s Stop delay F 0.00s

Grid Set4

**FW:** this series inverter is able to adjust inverter output power according to grid frequency.

**Droop F:** percentage of nominal power per Hz

For example, “Start freq F > 50.2Hz, Stop freq F < 51.5, Droop F=40%PE/Hz” when the grid frequency reaches 50.2Hz, the inverter will decrease its active power at Droop F of 40%. And then when grid system frequency is less than 50.1Hz, the inverter will stop decreasing output power.

For the detailed setup values, please follow the local grid code.

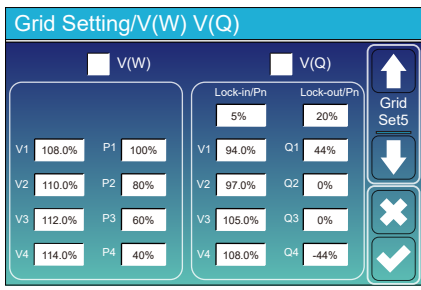

**V(W):** It is used to adjust the inverter active power according to the set grid voltage.  
**V(Q):** It is used to adjust the inverter reactive power according to the set grid voltage.  
 This function is used to adjust inverter output power (active power and reactive power) when grid voltage changes.

**Lock-in/Pn 5%:** When the inverter active power is less than 5% rated power, the VQ mode will not take effect.  
**Lock-out/Pn 20%:** If the inverter active power is increasing from 5% to 20% rated power, the VQ mode will take effect again.

For example: V2=110%, P2=80%. When the grid voltage reaches the 110% times of rated grid voltage, inverter output power will reduce its active output power to 80% rated power.

For example: V1=94%, Q1=44%. When the grid voltage reaches the 94% times of rated grid voltage, inverter output power will output 44% reactive output power.

For the detailed setup values, please follow the local grid code.

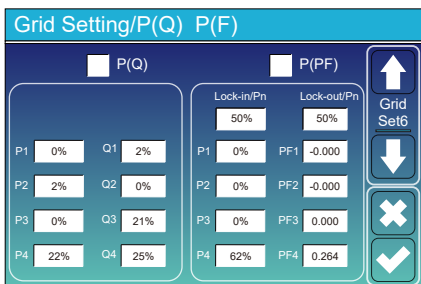

**P(Q):** It is used to adjust the inverter reactive power according to the set active power.

**P(PF):** It is used to adjust the inverter PF according to the set active power.

For the detailed setup values, please follow the local grid code.

**Lock-in/Pn 50%:** When the inverter output active power is less than 50% rated power, it won't enter the P(PF) mode.

**Lock-out/Pn 50%:** When the inverter output active power is higher than 50% rated power, it will enter the P(PF) mode.

Note: only when the grid voltage is equal to or higher than 1.05times of rated grid voltage, then the P(PF) mode will take effect.

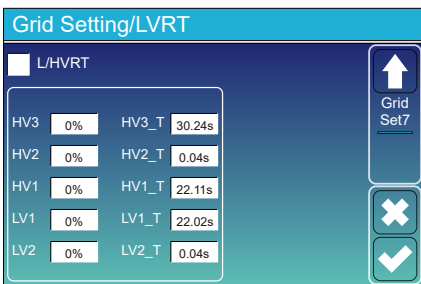

**Reserved:** This function is reserved. It is not recommended.

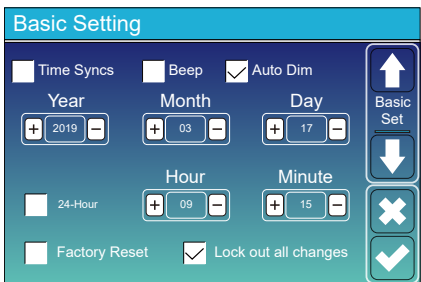

After setting grid parameters, please select "Lock out all changes" and enter password. If the engineer does not know the password, please contact your distributor.

### 5.8.3 Grid Parameter Check

After steps above, customers can see firmware version on main page grid parameters in grid settings on LCD.

## 5.9 Generator Port Use Setup Menu

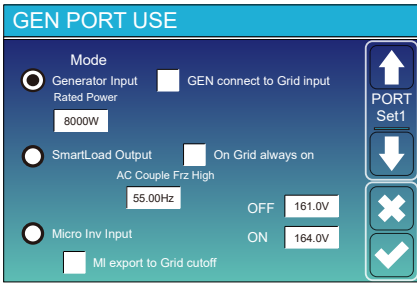

**Generator input rated power:** allowed Max. power from diesel generator.

**GEN connect to grid input:** connect the diesel generator to the grid input port.

**Smart Load Output:** This mode utilizes the Gen input connection as an output which only receives power when the battery SOC is above a user programmable threshold.

e.g. **ON: 100%, OFF: 95%:** When the battery bank SOC reaches 100%, Smart Load Port will switch on automatically and power the load connected. When the battery bank SOC < 95%, the Smart Load Port will switch off automatically.

### Smart Load OFF Batt

- Battery SOC at which the Smart load will switch off.

### Smart Load ON Batt

- Battery SOC at which the Smart load will switch on. simultaneously and then the Smart load will switch on.
- On Grid always on:** When click "on Grid always on" the smart load will switch on when the grid is present.

**Micro Inv Input:** To use the Generator input port as a micro-inverter on grid inverter input (AC coupled), this feature will also work with "Grid-Tied" inverters.

- \* **Micro Inv Input OFF:** when the battery SOC exceeds setting value, Microinverter or grid-tied inverter will shut down.
- \* **Micro Inv Input ON:** when the battery SOC is lower than setting value, Microinverter or grid-tied inverter will start to work.

**AC Couple Frz High:** If choosing "Micro Inv input", as the battery SOC reaches gradually setting value (OFF), during the process, the microinverter output power will decrease linear. When the battery SOC equals to the setting value (OFF), the system frequency will become the setting value (AC couple Frz high) and the Microinverter will stop working.

**MI export to grid cutoff:** Stop exporting power produced by the microinverter to the grid.

\* **Note:** Micro Inv Input OFF and On is valid for some certain FW version only.

## 5.10 Advanced Function Setup Menu

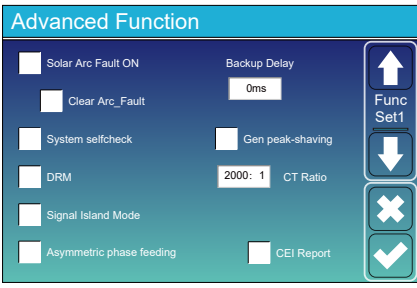

**Solar Arc Fault ON:** This is only for US.

**System selfcheck:** Disable. this is only for factory.

**Gen Peak-shaving:** Enable When the power of the generator exceeds the rated value of it, the inverter will provide the redundant part to ensure that the generator will not overload.

**DRM:** For AS4777 standard (Only DRM0 is available).

**Backup Delay:** When the grid cuts off, the inverter will give output power after the setting time.

For example, backup delay: 3ms. the inverter will give output power after 3ms when the grid cuts off.

Note: for some old FW version, the function is not available.

**Signal island mode:** If "Signal island mode" is checked and When inverter is in off-grid mode, the relay on the Neutral line (load port N line) will switch ON then the N line (load port N line) will bind to inverter ground.

### Inverter

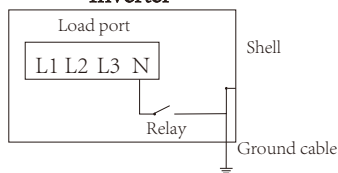

**Asymmetric phase feeding:** If it was checked, the inverter will take power from the grid balance of on each phase (L1/L2/L3) when needed.

## Advanced Function

Parallel      Modbus SN      Baud Rate  
 Master              
 Slave

↑ Par. Set3  
↓  
✕  
✓

EX\_Meter For CT

Meter Select  
 No Meter 0/3  
 CHNT  
 Eastron

**Ex\_Meter For CT:** when using zero-export to CT mode, the hybrid inverter can select EX\_Meter For CT function and use the different meters.e.g.CHNT and Eastron.

## 5.11 Device Info Setup Menu

### Device Info.

Inverter ID: 2102199870      Flash  
 HMI: Ver 1001-8010      MAIN:Ver2002-1046-1707

Alarms Code	Occurred
F13 Grid_Mode_changed	2021-06-11 13:17
F23 Tz_GFCL_OC_Fault	2021-06-11 08:23
F13 Grid_Mode_changed	2021-06-11 08:21
F56 DC_VoltLow_Fault	2021-06-10 13:05

↑ Device Info  
↓  
✕  
✓

This page show Inverter ID, Inverter version and alarm codes.

**HMI:** LCD version

**MAIN:** Control board FW version

## 6. Mode

### Mode I:Basic

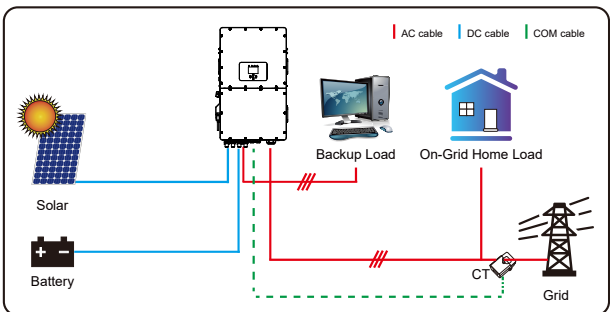

### Mode II: With Generator

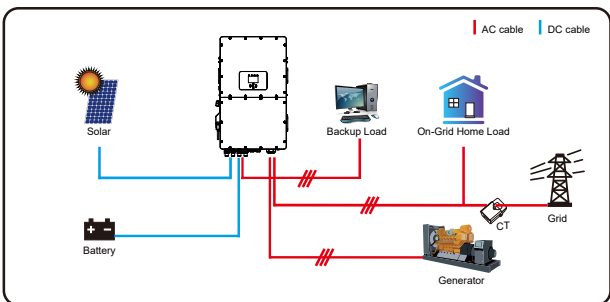

## Mode III: With Smart-Load

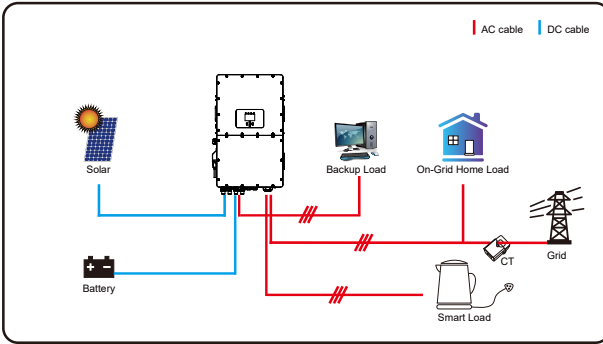

## Mode IV: AC Couple

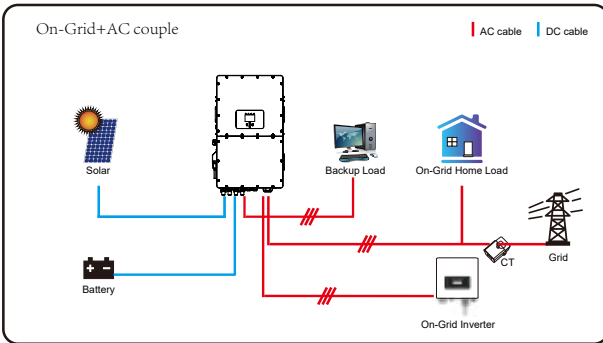

The 1st priority power of the system is always the PV power, then 2nd and 3rd priority power will be the battery bank or grid according to the settings. The last power backup will be the Generator if it is available.

## 7. Limitation of Liability

In addition to the product warranty described alone, the state and local laws and regulations provide financial compensation for the product's power connection (including violation of implied terms and warranties). The company hereby declares that the terms and conditions of the product and the policy can and can only legally exclude all liability within a limited scope.

<b>Error code</b>	<b>Description</b>	<b>Solutions</b>
F01	DC_Inversed_Failure	<ol style="list-style-type: none"> <li>1, Check the PV input polarity</li> <li>2, Seek help from us, if can not go back to normal state.</li> </ol>
F07	DC_START_Failure	<ol style="list-style-type: none"> <li>1, The BUS voltage can't be built from PV or battery.</li> <li>2, Restart the inverter, If the fault still exists, please contact us for help</li> </ol>
F13	Working_Mode_change	<ol style="list-style-type: none"> <li>1. When the grid type and frequency changed it will report F13;</li> <li>2. When the battery mode was changed to "No battery" mode, it will report F13;</li> <li>3. For some old FW version, it will report F13 when the system work mode changed;</li> <li>4. Generally, it will disappear automatically when shows F13;</li> <li>5. If it remains same, turn on DC and AC switch for one minute, then turn on the DC and AC switch.;</li> <li>6. Seek help from us, if can not go back to normal state.</li> </ol>
F15	AC_OverCurr_SW_Failure	<p>AC side over current fault</p> <ol style="list-style-type: none"> <li>1. Please check whether the backup load power and common load power are within the range;</li> <li>2. Restart and check whether it is normal;</li> <li>3. Seek help from us, if can not go back to normal state.</li> </ol>
F16	GFCI_Failure	<p>Leakage current fault</p> <ol style="list-style-type: none"> <li>1, Check the PV side cable ground connection</li> <li>2, Restart the system 2-3 times</li> <li>3, if the fault still existing, please contact us for help.</li> </ol>
F18	Tz_Ac_OverCurr_Fault	<p>AC side over current fault</p> <ol style="list-style-type: none"> <li>1. Please check whether the backup load power and common load power are within the range;</li> <li>2. Restart and check whether it is normal;</li> <li>3. Seek help from us, if cannot go back to normal state.</li> </ol>
F20	Tz_Dc_OverCurr_Fault	<p>DC side over current fault</p> <ol style="list-style-type: none"> <li>1. Check PV module connection and battery connection;</li> <li>2. When in the off-grid mode, the inverter startup with big power load, it may report F20. Please reduce the load power connected;</li> <li>3. If it remains same, turn on DC and AC switch for one minute, then turn on the DC and AC switch.;</li> <li>4. Seek help from us, if can not go back to normal state.</li> </ol>

<b>Error code</b>	<b>Description</b>	<b>Solutions</b>
F21	Tz_HV_Overcurr_fault	BUS over current. 1. Check the PV input current and battery current setting 2. Restart the system 2~3 times. 3. If the fault still exists, please contact us for help.
F22	Tz_EmergStop_Fault	Remotely shutdown 1, it tells the inverter is remotely controlled.
F23	Tz_GFCI_OC_Fault	Leakage current fault 1. Check PV side cable ground connection. 2. Restart the system 2~3 times. 3. If the fault still exists, please contact us for help.
F24	DC_Insulation_Fault	PV isolation resistance is too low 1. Check the connection of PV panels and inverter is firmly and correctly; 2. Check whether the PE cable of inverter is connected to ground; 3. Seek help from us, if can not go back to normal state.
F26	BusUnbalance_Fault	1. Please wait for a while and check whether it is normal; 2. When the load power of 3 phases is big different, it will report the F26. 3. When there's DC leakage current, it will report F26 4. Restart the system 2~3 times. 5. Seek help from us, if can not go back to normal state.
F29	Parallel_Comm_Fault	1. When in parallel mode, check the parallel communication cable connection and hybrid inverter communication address setting; 2. During the parallel system startup period, inverters will report F29. But when all inverters are in ON status, it will disappear automatically; 3. If the fault still exists, please contact us for help.
F34	AC_Overload_Fault	1, Check the backup load connection, make sure it is in allowed power range 2, If the fault still exists, please contact us for help
F41	Parallel_system_Stop	1, Check the hybrid inverter work status. If there's 1 pcs hybrid inverter shutdown, all hybrid inverters will report F41 fault. 2, If the fault still exists, please contact us for help
F42	Parallel_Version_Fault	Grid voltage fault 1. Check whether the AC voltage is within grid standard protection limits; 2. Check whether grid AC cables are firmly and correctly connected; 3. Seek help from us, if can not go back to normal state.

<b>Error code</b>	<b>Description</b>	<b>Solutions</b>
F47	AC_OverFreq_Fault	Grid frequency out of range 1. Check the frequency is in the range of specification or not; 2. Check whether AC cables are firmly and correctly connected; 3. Seek help from us, if can not go back to normal state.
F48	AC_UnderFreq_Fault	Grid frequency out of range 1. Check the frequency is in the range of specification or not; 2. Check whether AC cables are firmly and correctly connected; 3. Seek help from us, if can not go back to normal state.
F52	DC_VoltHigh_Fault	BUS voltage is too high 1. Check whether battery voltage is too high; 2. check the PV input voltage, make sure it is within the allowed range; 3. Seek help from us, if can not go back to normal state.
F53	DC_VoltLow_Fault	BUS voltage is too low 1. Check whether battery voltage is too low; 2. If the battery voltage is too low, using PV or grid to charge the battery; 3. Seek help from us, if can not go back to normal state.
F54	BAT2_VoltHigh_Fault	1. Check the battery 2 terminal voltage is high; 2. Restart the inverter 2 times and restore the factory settings; 3. Seek help from us, if can not go back to normal state.
F55	BAT1_VoltHigh_Fault	1. Check the battery 1 terminal voltage is high; 2. Restart the inverter 2 times and restore the factory settings; 3. Seek help from us, if can not go back to normal state.
F56	BAT1_VoltLow_Fault	1. Check the battery 1 terminal voltage is low; 2. Restart the inverter 2 times and restore the factory settings; 3. Seek help from us, if can not go back to normal state.
F57	BAT2_VoltLow_Fault	1. Check the battery 2 terminal voltage is low; 2. Restart the inverter 2 times and restore the factory settings; 3. Seek help from us, if can not go back to normal state.
F58	Battery_comm_Lose	1, It tells the communication between hybrid inverter and battery BMS disconnected when "BMS_Err-Stop" is active; 2, If don't want to see this happen, you can disable "BMS_Err-Stop" item on the LCD; 3, If the fault still exists, please contact us for help
F62	DRMs0_stop	1, the DRM function is for Australia market only; 2, Check the DRM function is active or not; 3, Seek help from us, if can not go back to normal state after restart the system.
F63	ARC_Fault	1. ARC fault detection is only for US market; 2. Check PV module cable connection and clear the fault; 3. Seek help from us, if can not go back to normal state
F64	Heatsink_HighTemp_Fault	Heat sink temperature is too high 1. Check whether the working environment temperature is too high; 2. Turn off the inverter for 10mins and restart; 3. Seek help from us, if can not go back to normal state.

Chart 7-1 Fault information

---

Under the guidance of our company, customers return our products so that our company can provide service of maintenance or replacement of products of the same value. Customers need to pay the necessary freight and other related costs. Any replacement or repair of the product will cover the remaining warranty period of the product. If any part of the product or product is replaced by the company itself during the warranty period, all rights and interests of the replacement product or component belong to the company.

Factory warranty does not include damage due to the following reasons:

- Damage during transportation of equipment ;
- Damage caused by incorrect installation or commissioning ;
- Damage caused by failure to comply with operation instructions, installation instructions or maintenance instructions ;
- Damage caused by attempts to modify, alter or repair products ;
- Damage caused by incorrect use or operation ;
- Damage caused by insufficient ventilation of equipment ;
- Damage caused by failure to comply with applicable safety standards or regulations ;
- Damage caused by natural disasters or force majeure (e.g. floods, lightning, overvoltage, storms, fires, etc.)

In addition, normal wear or any other failure will not affect the basic operation of the product. Any external scratches, stains or natural mechanical wear does not represent a defect in the product.

## 8. Datasheet

<b>Model</b>	<b>SUN-29.9K-SG01HP3-AU-BM3</b>	<b>SUN-30K-SG01HP3-AU-BM3</b>	<b>SUN-35K-SG01HP3-AU-BM3</b>	<b>SUN-40K-SG01HP3-AU-BM4</b>	<b>SUN-50K-SG01HP3-AU-BM4</b>
<b>Battery Input Data</b>					
Battery Type	Lithium-ion				
Battery Voltage Range(V)	160-800				
Max. Charging Current(A)	50+50				
Max. Discharging Current(A)	50+50				
Charging Strategy for Li-ion Battery	Self-adaption to BMS				
Number of Battery Input	2				
<b>PV String Input Data</b>					
Max. PV Input Power(W)	44850	45000	52500	60000	75000
Max. PV Input Voltage(V)	1000				
Start-up Voltage(V)	180				
MPPT Voltage Range(V)	150-850				
Full Load MPPT Voltage Range(V)	360-850	360-850	420-850	360-850	450-850
Rated PV Input Voltage(V)	600				
Max. Operating PV Input Current(A)	36+36+36			36+36+36+36	
Max. Input Short-Circuit Current(A)	55+55+55			55+55+55+55	
No.of MPPT Trackers/No.of String Per MPPT Tracker	3/2+2+2			4/2+2+2+2	
Max. Inverter Backfeed Current to The Array	0				
<b>AC Input/Output Data</b>					
Rated AC Input/Output Active Power(W)	29900	30000	35000	40000	50000
Max. AC Input/Output Apparent Power(VA)	29900	30000	35000	40000	50000
Peak Power (off-grid)(W)	1.5 times of rated power, 10s				
Rated AC Input/Output Current(A)	43.4	43.5	50.8	58	72.5
Max. AC Input/Output Current(A)	43.4	43.5	50.8	58	72.5
Max. Three-phase Unbalanced Output Current(A)	60	60	60	70	83.3
Max. Continuous AC Passthrough (grid to load)(A)	200				
Rated Input/Output Voltage/Range(V)	230/400V 0.85Un-1.1Un				
Grid Connection Form	3L+N+PE				
Rated Input/Output Grid Frequency/Range	50Hz/45Hz-55Hz 60Hz/55Hz-65Hz				
Power Factor Adjustment Range	0.8 leading-0.8 lagging				
Total Current Harmonic Distortion THDi	<3% (of nominal power)				
DC Injection Current	<0.5%In				
<b>Efficiency</b>					
Max. Efficiency	97.60%				
Euro Efficiency	97.00%				
MPPT Efficiency	>99%				
<b>Equipment Protection</b>					
DC Polarity Reverse Connection Protection	Yes				
AC Output Overcurrent Protection	Yes				
AC Output Overvoltage Protection	Yes				
AC Output Short Circuit Protection	Yes				
Thermal Protection	Yes				
DC Terminal Insulation Impedance Monitoring	Yes				
DC Component Monitoring	Yes				
Ground Fault Current Monitoring	Yes				

Power Network Monitoring	Yes
Island Protection Monitoring	Yes
Earth Fault Detection	Yes
DC Input Switch	Yes
Overvoltage Load Drop Protection	Yes
Residual Current (RCD) Detection	Yes
Anti-islanding Protection	Yes(Active Frequency Shift)
Surge Protection Level	TYPE II(DC), TYPE II(AC)
<b>Interface</b>	
Communication Interface	WIFI, RS485, CAN
PV Connection	VP-D4
<b>General Data</b>	
Operating Temperature Range	-40 to +60 C , >45 C Derating
Permissible Ambient Humidity	0-100%
Permissible Altitude	2000m
Noise	≤ 65 dB(A)
Ingress Protection(IP) Rating	IP 65
Inverter Topology	Non-Isolated
Over Voltage Category	OVC II(DC), OVC III(AC)
Cabinet size(W*H*D) [mm]	527W×894H×294D (Excluding connectors and brackets)
Weight(kg)	80
Warranty	5 Years/10 Years the Warranty Period Depends the Final Installation Site of Inverter, More Info Please Refer to Warranty Policy
Type of Cooling	Intelligent Air Cooling
Grid Regulation	AS/NZS 4777.2
Safety EMC/Standard	IEC/EN 61000-6-1/2/3/4, IEC/EN 62109-1, IEC/EN 62109-2

## 9.Package and transport inverter

Usually placed inverter in the packing box with tape sealing, if the inverter cannot reoccupy, you can choose a cheap carton for packaging. Carton requirements must meet the size of the inverter and can support inverter machine overall weight.

Series frequency converter in the process of moving, please note: handle with care, do not touch the inverter, put as flat as possible.

## 10.Disposing of the inverter

Do not dispose of inverter together with household waste. Please accordance with the disposal regulations for electronic waste which apply at the installation site at that time. Ensure that the old unit and, where applicable, any accessories are disposed of in a proper manner.

# 11. Appendix I

## Definition of RJ45 Port Pin for BMS1

No.	RS485 Pin
1	485_B
2	485_A
3	GND_485
4	CAN-H1
5	CAN-L1
6	GND_485
7	485_A
8	485_B

BMS1 Port

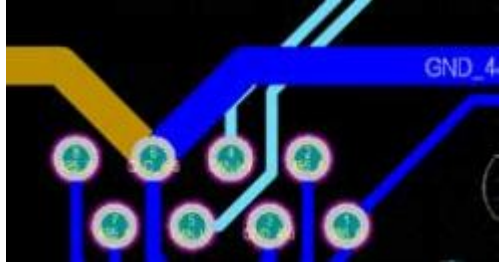
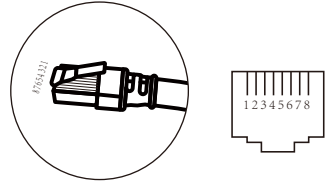

## Definition of RJ45 Port Pin for BMS2

No.	RS485 Pin
1	485_B
2	485_A
3	GND_485
4	CAN-H2
5	CAN-L2
6	GND_485
7	485_A
8	485_B

BMS2 Port

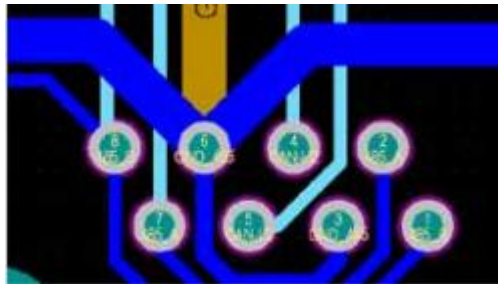

## Definition of RJ45 Port Pin for Meter

No.	Meter-485 Pin
1	METER-485_B
2	METER-485_A
3	GND_COM
4	METER-485_B
5	METER-485_A
6	GND_COM
7	--
8	--

Meter Port

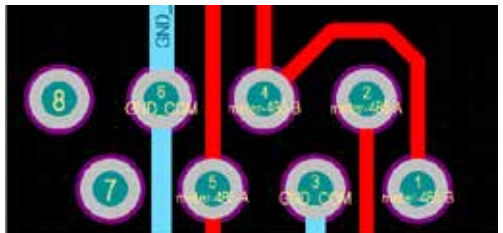
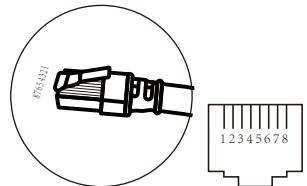

**Definition of RJ45 Port Pin for RS485**

No.	RS485 Pin
1	Modbus-485_B
2	Modbus-485_A
3	GND_485
4	--
5	--
6	GND_485
7	Modbus-485_A
8	Modbus-485_B

**RS485 Port**

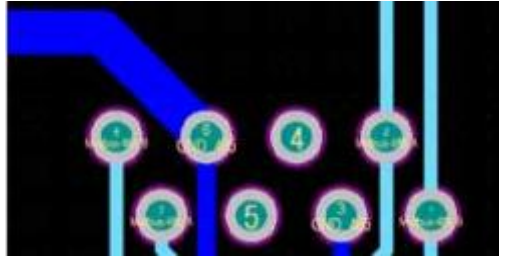

**Definition of RJ45 Port Pin for DRM**

No.	DRM Pin
1	DRM1/5
2	DRM2/6
3	DRM3/7
4	DRM4/8
5	REF-GEN/0
6	GND_LCD
7	NetJ1_7
8	NetJ1_7

**DRM Port**

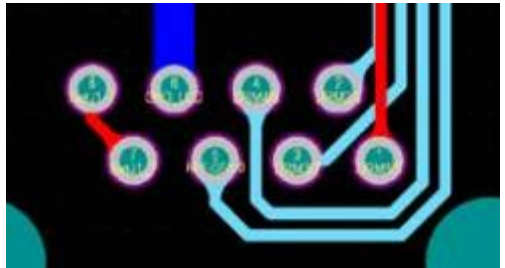

**RS232**

No.	WIFI/RS232
1	
2	TX
3	RX
4	
5	D-GND
6	
7	
8	
9	12Vdc

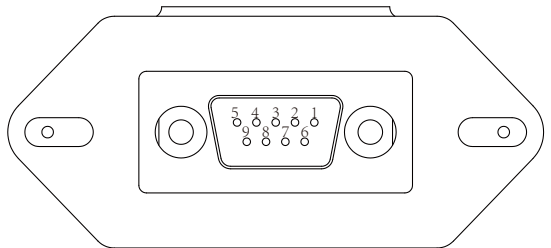

**WIFI/RS232**

This RS232 port is used to connect the wifi datalogger

## 12. Appendix II

1. Split Core Current Transformer (CT) dimension: (mm)
2. Secondary output cable length is 4m.

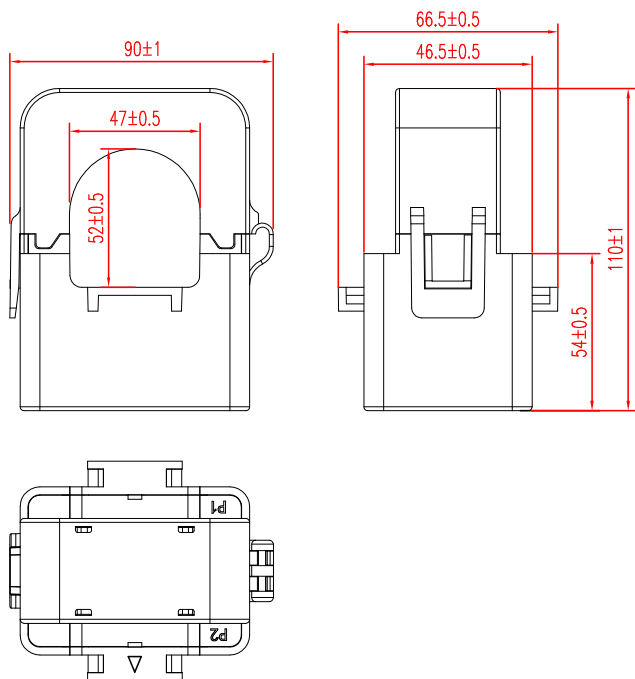

## NINGBO DEYE INVERTER TECHNOLOGY CO., LTD.

Add.: No.26 South YongJiang Road, Daqi, Beilun, NingBo, China.

Tel.: +86 (0) 574 8622 8957

Fax.: +86 (0) 574 8622 8852

E-mail: [service@deye.com.cn](mailto:service@deye.com.cn)

Web.: [www.deyeinverter.com](http://www.deyeinverter.com)



30240301002245